

**DRAINAGE REPORT
FOR THE**

**GOUIN DRAIN & BRANCHES
(LITTLE RIVER OUTLET)**

**TOWN OF TECUMSEH
CITY OF WINDSOR**



(FINAL – COUNCIL CONSIDERATION)

20 JANUARY 2023

MARK D. HERNANDEZ, P.ENG.

FILE No. 17-6773

TECUMSEH FILE No. E09GO(37)

Mayor and Council
The Corporation of the Town of Tecumseh
917 Lesperance Road
Tecumseh, Ontario
N8N 1W9



3200 Deziel Drive
Suite 608
Windsor, Ontario
Canada
N8W 5K8
Telephone
519.948.5000
Fax
519.948.5054

**Drainage Report for the
GOUIN DRAIN & BRANCHES
(LITTLE RIVER OUTLET)
In the Town of Tecumseh &
City of Windsor**

Mayor and Council:

Instructions

The Town of Tecumseh received a request from the landowner of property Roll No. 570-43110 located in Block 'A' to repair and improve the Gouin Drain. Council accepted the request under Section 78 of the Drainage Act and on 14 November 2017 appointed Dillon Consulting Limited to prepare a report.

Watershed Description

The Gouin Drain alignment commences on the line between Lot 149 and Lot 150, Concession 1 in the Town of Tecumseh. It flows in a westerly direction, turning north at the west limit of Lot 149 toward the north side of Gouin Street. Here, it turns west for approximately 124 metres before turning north for 75 metres where it again then flows westerly to its current outlet being the E.C. Row Expressway roadside ditch. In the previous 1987 Gouin Drain report, Station 0+000 was defined as the southern limit of the E.C. Row Expressway. As part of this report, we have recommended a further extension of the Gouin Drain by way of deepening the existing highway ditch on the north side of E.C. Row Expressway. The Gouin Drain would continue northerly from the current outlet, crossing the highway and then turning westerly again to its outlet into the Little River Drain.



The total length of the drain is approximately 3,286 metres, of which the downstream extension comprises of 1,032 metres. The watershed area is approximately 211 hectares (521 acres) which consists of approximately 114 hectares (282 acres) within the Town of Tecumseh and 96 hectares (238 acres) within the City of Windsor.

The lands comprising the watershed are under mixed agricultural, and residential use. Notably, a portion of the E.C. Row Expressway will now also comprise part of the watershed. There is little topographic relief. From the Ontario Soil Survey, the principle surficial soil in the study area is described as Brookston Clay. Brookston clay is characterized as a very slow draining soil type. Most of the agricultural land parcels are systematically tiled.

Drain History

The recent history of Engineers' reports for the Gouin Drain follows:

- **28 January 1987 by Wm. J. Settingington, P.Eng.:** This reconsidered report recommends brushing and removal of sediment along the entirety of the drain, along with deepening/widening and relocation of the drain in select locations along its length. This report also recommended the removal and replacement of access bridges along the drain.
- **2 October 1981 by C. G. Russell Armstrong, P.Eng.:** This report found the drain to be “badly out of repair”. The recommended work included the repair and improvement of the Gouin Drain, including a thorough brushing and cleanout. It also recommended that, the drain be deepened from E.C. Row Expressway to Gouin Street. The report recommends that most upstream 28 metres of drain be enclosed with a 450 mm (18”) diameter plastic pipe, and that the existing culverts with the exception of the Shawnee Road culvert, be replaced and enlarged to accommodate for flows from a proposed development.

On-Site Meeting

The Municipality invited the affected landowners to attend an on-site meeting on 8 February 2018 and 6 April 2018 to better understand the nature of the request. The concerns brought to the meeting are as follows:

- Conveyance of water is problematic due to overgrowth along the banks, and there is stagnant water in many areas of the drain.

- Flooding along the drain and the upstream residential area, is prevalent during heavy rainfalls.

An additional on-site meeting was held on January 22, 2020 to discuss the nature of the rear yard drainage for the properties within the Gouin Drain Branch North and South as well as any drainage issues these properties are experiencing.

Records of the meeting are provided in Schedule 'A-1', Schedule 'A-2', and Schedule 'A-3' which is appended hereto.

Public Information Centre Meeting

The Municipality held a Public Information Centre (PIC) on 28 April, 2022 to present the works proposed on the on the Gouin Drain and Branches. Based on discussion with the landowners and upon further review of the report, the following changes have been made:

- Block 'C' has been eliminated from the Schedule of Assessments and Schedule of Future Maintenance for the Gouin Drain Branch North and has been replaced with full assessment schedules, and
- An additional secondary working corridor was added on the north side of the Gouin Drain between Station 2+162 and Station 2+680.

Records of the meeting are provided in Schedule 'A-4' which is appended hereto.

Survey

Our survey and examination of the Gouin Drain was carried out in April 2018. Additional drain data was collected in June 2018 and May 2019. The survey comprised the recording of topographic data and examining the channel for available depth necessary to provide sufficient drainage, as well as existing stormwater infrastructure. We commenced the survey at the outlet of the existing roadside ditch which outlets to the Little River Drain on the north side of E.C. Row Expressway within the City of Windsor. We then proceeded upstream along the roadside ditch, crossing E.C. Row Expressway to Anchor Drive where the existing Gouin Drain currently outlets. We continued upstream along the Gouin Drain in an easterly direction, crossing Banwell Road and into the Town of Tecumseh to the most upstream section of the drain at the line between Lot 149 and Lot 150 located within the residential

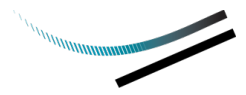

area of Corbi Lane and Shawnee Road.

Our survey revealed a significant amount of overgrown brush and vegetation with frequent accumulations of debris, forming blockages within the channel. There is a uniform build-up of sediment averaging 200 mm to 450 mm above the design bottom in the 1987 engineer's report.

The drain alignment shown within the Settingington, 1987 report shows the alignment of the Gouin Drain passing through the rear yard of homes that front the west side of Shawnee Road. Since the previous Engineer's Report, the drain was altered to accommodate a subdivision development in 1997. This portion of drain, as well as connected storm sewers were inspected with CCTV sewer cameras in April 2019 to determine the condition and size of the sewers. Inspections revealed the sewer behind the houses fronting Corbi Lane includes a partially crushed 1050 mm diameter CSP draining northerly to a 300 mm diameter HDPE pipe in good condition which outlets to the 1500 mm diameter concrete pipe under Gouin Street. The inspection also revealed a 300 mm diameter HDPE pipe draining southerly to a 600 mm diameter concrete sewer which outlets to the 1050 mm concrete trunk sewer underneath Corbi Lane, all of which were found in good condition.

Various utilities were found crossing the bridge over top the culvert near Lauzon Road in the City of Windsor, including a 250 mm (10") diameter high pressure transmission gas line and a 150 mm (6") diameter high pressure distribution gas line, Bell Fibre cables, a 300 mm (12") diameter watermain, and an underground power duct. Depths of the gas and Bell Fibre utilities were unknown, so in September 2020, these utilities were revealed using hydro-excavation to determine the existing depth of cover.

Excess Soils Management

In April 2021 in consultation with the Town of Tecumseh, Dillon Consulting completed an Environmental Review and Soil Characterization Report following the requirements of *Ontario Regulation 406/19 – On-Site Excess Soil Management* (O. Reg 406/19) to determine the level of contamination of the excess soils generated from the Gouin Drain improvements and confirm appropriate reuse criteria for the excess soils.

The Environmental Review investigated for potential or actual sources of environmental contamination that would affect the reuse capability of any



excavated soils as a result of the Gouin Drain improvements along the north side of the E.C. Row Expressway. A review of historical and current records of the surrounding area and a cursory site inspection were completed to identify areas of potential environmental concern, and to support planning of the soil sampling program. The review identified that the downstream most 315 metres of the drain is a site of a cutting oil spill in 1988. Any soil excavated from this length of drain will be considered contaminated and therefore has no allowable reuse potential.

Soil sampling was conducted on March 5, 2021 with the use of an excavator. The sampling program consisted of 13 test pits evenly distributed over the length of drain located on the north side of E.C. Row Expressway, excluding the downstream section of drain identified in the Environmental Review as having been subject to a cutting oil spill. Soil sample analyses within the remaining section of drain along the north side of the expressway indicate that most of the soil is to be managed as waste, with the exception of a 230 m length of drain which has some reuse potential as described in the Specifications.

Excess soil generated from the report recommendations but not captured in the soil sampling work described shall adhere to the relevant requirements as set out in O. Reg 406/19.

Design Considerations

The Design and Construction Guidelines published by the Ontario Ministry of Agriculture, Food and Rural Affairs (OMAFRA) recommends that open drainage systems and farm crossings serving farmlands be designed to effectively contain and convey the peak runoff generated from a storm event having a frequency of occurrence of 1 in 2 years. The arterial and collector road bridges have been designed for a storm event having a frequency of 1 in 10 years and analyzed for a 1 in 25 year storm event to confirm that flows do not overtop the roadway. Likewise, the 1 in 5 year storm event was considered in determining hydraulic capacity of the culvert crossing Shawnee Road, and a 1 in 25 year storm event was considered for the culvert crossing E.C. Row Expressway.

In addition, we have reviewed the performance of the outlet portion of drain in an improved state during the 1:100 year storm event and have found that



the hydraulic grade line is reduced in the drain due to the improvements recommended downstream of the E.C. Row Expressway Bridge. We have also reviewed the Little River Floodplain Mapping Study which is currently being completed and have found that the Gouin Drain does not fall within an existing floodplain.

We believe that these design standards should provide a reasonable level of service, but it should be clearly understood that runoff generated from large storms or fast snow melts may sometimes exceed the capacity of the proposed systems and result in surface ponding for short periods of time. It should be further noted that some of the agricultural lands have been identified for future development. When that occurs, stormwater management for the affected lands and further improvements to the drain may be required.

The upper most portions of the Gouin Drain have been altered from an open drain to a covered drain during the residential development of the area completed in 1997. Sections of this covered drain have collapsed and no longer provide sufficient drainage to the abutting lands.

A 250 mm diameter corrugated steel pipe orifice was originally specified in the design drawings for the development along Corbi Lane on the lower end of the enclosed upstream Gouin Drain portion along Gouin Street. Alternative forms of stormwater management were considered including a temporary stormwater pond in the open farm fields west of Corbi Lane. However, upon further investigation in the field, it was determined that the orifice was not in place and so an alternative form of storage was not required.

NextStar Battery Production Facility

Property Roll Nos. 090-040-00103, 090-040-03403 & 090-040-4000 within the City of Windsor were previously used for agricultural purposes, however these properties are being considered for a battery production facility that is currently under construction. Bridge Nos. 8 through 12 currently provide access to said lands.

The proposed development is required to have stormwater management controls as to not adversely impact the level of service provided by the drain.

Existing Conditions and Recommendations (Gouin Drain)

We have determined that the current outlet of the Gouin Drain into the E.C. Row Expressway roadside ditch is insufficient and is required to be extended to the Little River Drain. It is recommended that the roadside ditch along the north side of E.C. Row Expressway, including existing structures within this drain, be incorporated as part of the Gouin Drain and improved as described herein to provide sufficient outlet for upstream lands.

The last report for repair and improvement of the drain upstream of Anchor Drive was completed in 1987. The drain will require a bottom cleanout to align with the 1987 profile with minor adjustments as shown on the profile drawings attached herein. Generally, the drain banks are reasonably well grassed and stabilized. The new section of drain downstream of Anchor Drive will require deepening to achieve hydraulic capacity to accommodate the flows from the original Gouin Drain watershed as well as the contributing flows from the E.C. Row Expressway roadside ditch system.

All of the access bridges were inspected during the course of our investigation. Our assessment identified culverts that are in poor condition, good condition and culverts that are still in serviceable condition, but will likely require replacement in the next 5 to 10 years. Bridge Nos. 1 and 3 are recommended for immediate replacement to accommodate deepening of the drain. Bridge Nos. 5, 6, 7, 13, 14, 15, 17, 18, and 20 are recommended for future replacement. Bridge Nos. 2, 8, 9, 10 and 19 are recommended for removal along with the recommended drain cleanout. At the request of the landowner, Bridge No. 16 is recommended not to be replaced and is to be removed at the end of its serviceable life. The said bridge serves as a secondary access to the property.

Bridge Nos. 11 & 12 will be recommended to be removed and replaced with a new enclosure to service the new NextStar battery production plant, however these recommendations are included under a separate report. No recommendations are being made for these bridges under this report.

It should be noted that there is limited available cover for the proposed bridge replacements. To address this limitation, pipe arches were considered to meet both the cover and flow requirements for Bridges No. 1, 3, 6, 7, 13, 14, 15, 17 and 18.



Bridge No. 4 (E.C. Row Expressway crossing) was assessed for hydraulic conveyance under the 25 year design storm and was found sufficient with the recommended improvements.

We also recommend the bottom of the drain be cleaned out including through existing bridges that are to remain.

Specific structure numbers have been designated for ease of reference between the specifications and the drawings. The locations, dimensions, condition and use of each structure are as follows:

Bridge No. 1: Station 0+200 Enbridge Gas, Enwin Water, Enwin Powerlines & Bell Canada

Twin 28 m long, 1370 mm x 1000 mm corrugated steel pipe arches with concrete end protection and grassed driveway currently provides access and protection to various utilities crossing over the culvert, including a 250 mm (10") diameter high pressure transmission gas line, a 150 mm (6") diameter high pressure distribution gas line, a dual Bell Fibre duct, a 300 mm (12") diameter watermain, and an underground power duct. A 525 mm (21") diameter sanitary sewer exists beneath the culvert. This culvert was determined to have adequate capacity to convey the 2 year design storm.

To accommodate the deepening of the drain and to reduce debris build up caused by twin culvert, we recommend this bridge be replaced with a single new 32 m long, 2500 mm x 1830 mm corrugated steel pipe arch (CSPA) with rip rap end walls with filter fabric underlay, providing a minimum a 24 m grassed top width.

Utility supports and third party utility inspection is anticipated during this work.

Bridge No. 2: Station 0+534 City of Windsor

Twin 6 m long, 1900 mm x 1050 mm corrugated steel pipe arches with concrete headwall end protection and grassed driveway exists.

There is no longer evidence that this bridge is used, we recommend it be removed to accommodate the deepening of the drain.

Bridge No. 3: Station 0+825 Enwin Powerlines

Twin 7 m long, 1520 mm x 1160 mm corrugated steel pipe arches with

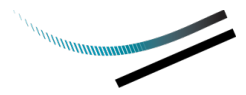

concrete end protection and grassed driveway currently provides access to Enwin Powerlines utilities. This culvert was determined to have inadequate capacity to convey the 2 year design storm when considering the limited depth of the drain when compared to the existing downstream Bridge No. 1.

To accommodate the deepening of the drain and to reduce debris build up caused by twin culverts, we recommend this bridge be replaced with a single new 16 m long, 2500 mm x 1830 mm corrugated steel pipe arch (CSPA) with rip rap end walls with filter fabric underlay, providing a minimum 7.3 m gravel driveable top width.

Bridge No. 4: Station 0+958 City of Windsor (E.C. Row Expressway)

Twin 40 m long, 3050 mm x 1830 mm concrete box culverts with 45° bevelled concrete headwalls constitutes the drain crossing for the EC Row expressway. This bridge appears to be in good repair and has sufficient capacity to convey the flows from the 25 year design storm. However, drain bottom scour is evident on the upstream and downstream ends of the culvert as a result of increased velocities upon entering and exiting the culvert.

We recommend the repair of the drain on the upstream and downstream ends of the E. C. Row Expressway culvert by lining with stone erosion protection (minimum 300 mm thickness) along the drain bottom and drain banks. The original design of this bridge from Rankin McCormick (1979) specified clear stone be laid to a depth of 0.76 m (2'8") along the entire length of culvert, however no evidence of clear stone bottom was found. The stone erosion protection to be laid shall transition the drain bottom within the culvert and the drain bottom upstream and downstream of the culvert.

Bridge No. 5: Station 1+020 City of Windsor (Anchor Drive)

Twin 19 m long, 1520 mm diameter corrugated steel pipes with block end walls and asphalt roadway provides a road crossing. An 18.3 m long culvert was shown at this location on the 1987 profile. This culvert was determined to have adequate capacity to convey the 10 year design storm.

We anticipate that this culvert will require replacement within the next 10 years or sooner if conditions warrant. We recommend that in the future the culvert be replaced with a new 18 m long, twin 1500 mm diameter concrete pipes complete with interlocking pre-cast concrete block end walls, providing



a minimum 8.5 m wide driveable asphalt surface. We find it will be necessary to excavate the southern bank of the Gouin Drain to allow for sufficient separation of the twin pipes. It is also recommended to relocate the outlet of the 750 mm diameter CSP road crossing into the proposed concrete pipe. The drain banks are also recommended to be lined with stone erosion protection with filter fabric underlay as shown on the plans herein.

Bridge No. 6: Station 1+109 Gary Barbesin (Roll No. 070-650-01303)

A 7.6 m long, 2240 mm x 1630 mm corrugated steel pipe arch with bagged concrete end protection and a gravel driveway provides access to this property. A 7.3 m long culvert was shown at this location on the 1987 profile. This culvert was determined to have adequate capacity to convey the 2 year design storm.

We anticipate that this culvert will require replacement within the next 10 years or sooner if conditions warrant. We recommend that in the future the culvert be replaced with a new 14 m long, 2230 mm x 1700 mm aluminized corrugated steel pipe arch complete with rip rap end walls with filter fabric underlay, providing a minimum 7.3 m wide gravel surface.

Bridge No. 7: Station 1+191 Jamieson Laboratories Inc. (Roll No. 090-040-01351)

A 40.5 m long, 2440 mm x 1600 mm corrugated steel pipe arch with rip rap end protection and asphalt driveable top width provides secondary access to property Roll No. 090-040-01351 through property Roll No. 070-650-01303. A culvert was not shown at this location on the profile in the 1987 report, therefore the origin is unknown. This culvert was determined to have adequate capacity to convey the 2 year design storm.

We anticipate that this culvert will not require replacement within the near future. However, when needed we recommend that the culvert be replaced with a new 41 m long 2230 mm x 1700 mm corrugated steel pipe arch with rip rap end protection and asphalt roadway provides a 22 m asphalt driveable top width with a 5.3 m gravel shoulder on the west side of the driveway and a 6.7 m gravel shoulder on the east side of the driveway, consistent with existing conditions.

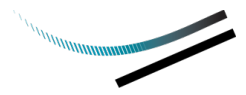

Bridge No. 8: Station 1+278 City of Windsor (Roll No. 090-040-03403)

A 9.7 m long, 2240 mm x 1630 mm corrugated steel pipe arch with bagged concrete end protection and a gravel driveway provides access to this property. A 7.3 m long culvert was shown at this location on the 1987 profile.

This culvert is recommended to be removed as the battery production facility will have alternate access detailed under a separate report.

Bridge No. 9: Station 1+442 City of Windsor (Roll No. 090-040-00103)

An 8.2 m long, 2240 mm x 1630 mm corrugated steel pipe arch with bagged concrete end protection and a gravel driveway provides access to this property. A culvert was not shown at this location on the 1987 profile, therefore the origin is unknown.

This culvert is recommended to be removed as the battery production facility will have alternate access detailed under a separate report.

Bridge No. 10: Station 1+646 City of Windsor (Roll No. 090-040-00103)

A 7.8 m long, 2240 mm x 1630 mm corrugated steel pipe arch with concrete headwalls and a gravel driveway provides secondary access to this property. A 7.8 m long culvert was shown at this location on the 1987 profile.

This culvert is recommended to be removed as the battery production facility will have alternate access detailed under a separate report.

Bridge No. 11: Station 1+955 City of Windsor (Roll No. 090-040-00103)

A 7.9 m long, 2240 mm x 1630 mm corrugated steel pipe arch with bagged concrete end protection and a gravel driveway provides access to this property. A 7.3 m long culvert was shown at this location on the 1987 profile. This culvert was determined to have adequate capacity to convey the 2 year design storm.

Access to the battery production facility is being recommended under a separate report that will include removal of the existing bridge. No recommendations are being made under this report.

Bridge No. 12: Station 1+980 City of Windsor (Roll No. 090-040-00103)

A 7.6 m long, 2240 mm x 1630 mm corrugated steel pipe arch with bagged concrete end protection and a gravel driveway provides secondary access to



this property. A 7.3 m long culvert was shown at this location on the 1987 profile. This culvert was determined to have adequate capacity to convey the 2 year design storm.

Access to the battery production facility is being recommended under a separate report that will include removal of the existing bridge. No recommendations are being made under this report.

Bridge No. 13: Station 2+116 City of Windsor (Banwell Road)

A 15.6 m long, 2240 mm x 1630 mm corrugated steel arch pipe with bagged concrete end protection and asphalt roadway provides a road crossing. A 15.3 m long culvert was shown at this location on the 1987 profile.

We have considered the proposed access culvert for the battery production facility which is to include a 178 m long culvert directly attached to the downstream end of the existing Bridge No. 13 culvert.

We anticipate that the existing road portion of culvert will require replacement within the next 10 years or sooner if conditions warrant. We recommend that in the future the culvert be replaced with a new 18 m long, 2500 mm x 1830 mm polymer laminated corrugated steel pipe arch complete with concrete block end walls and a 12.0 m asphalt driveable top width.

Bridge No. 14: Station 2+208 507822 Ontario Inc. First Mirage Management Inc. (Roll No. 570-46201)

A 7.8 m long, 2240 mm x 1630 mm corrugated steel pipe arch with bagged concrete end protection and gravel driveway provides access to this property. A 7.3 m long culvert was shown at this location on the 1987 profile. This culvert was determined to have adequate capacity to convey the 2 year design storm.

We anticipate that this culvert will require replacement within the next 10 years or sooner if conditions warrant. We anticipate that this culvert will not require replacement within the near future, but in the future when the culvert needs to be replaced, we recommend that it is replaced with a with a new 16 m long, 2230 mm x 1700 mm aluminized corrugated steel pipe arch complete with rip rap end walls with filter fabric underlay and a 7.3 m granular driveable top width.

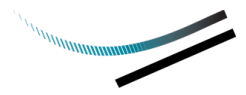

Bridge No. 15: Station 2+359 1486044 Ontario Ltd. (Roll No. 570-45950)

A 7.7 m long, 2240 mm x 1630 mm corrugated steel pipe arch with bagged concrete end protection and a gravel driveway provides access to this property. A 7.3 m long culvert was shown at this location on the 1987 profile. This culvert was determined to have adequate capacity to convey the 2 year design storm.

We anticipate that this culvert will require replacement within the next 10 years or sooner if conditions warrant. We recommend that in the future the culvert be replaced with a new 16 m long, 2230 mm x 1700 mm aluminized corrugated steel pipe arch complete with rip rap end walls with filter fabric underlay, providing a minimum 7.3 m wide gravel surface.

Bridge No. 16: Station 2+445 1486044 Ontario Ltd. (Roll No. 570-45950)

A 7.7 m long, 2240 mm x 1630 mm corrugated steel pipe arch with bagged concrete end protection and a gravel driveway provides secondary access to this property. A culvert was not shown at this location on the profile in the 1987 report, its origin is unknown. This culvert was determined to have adequate capacity to convey the 2 year design storm.

We anticipate that this culvert will require removal within the next 10 years or sooner if conditions warrant. The access bridge serves as a secondary access to the farm. The property owner has requested that the culvert not be removed immediately, but removed once the bridge has reached the end of its serviceable life.

Bridge No. 17: Station 2+567 1486044 Ontario Ltd. (Roll No. 570-45930)

A 7.5 m long, 2240 mm x 1630 mm corrugated steel pipe arch with bagged concrete end protection and a gravel driveway provides access to this property. A 7.3 m long culvert was shown at this location on the 1987 profile. This culvert was determined to have adequate capacity to convey the 2 year design storm.

We anticipate that this culvert will require replacement within the next 10 years or sooner if conditions warrant. We recommend that in the future the culvert be replaced with a new 16 m long, 2230 mm x 1700 mm aluminized corrugated steel pipe arch complete with rip rap end walls with filter fabric underlay, providing a minimum 7.3 m wide gravel surface.

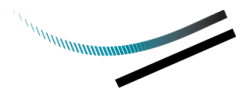

Bridge No. 18: 2034053 Ontario Ltd. Station 2+675 (Roll No. 570-45902)

A 7.6 m long, 2240 mm x 1630 mm corrugated steel pipe arch with bagged concrete end protection and a gravel driveway provides access to this property. A 7.3 m long culvert was shown at this location on the 1987 profile. This culvert was determined to have adequate capacity to convey the 2 year design storm.

We anticipate that this culvert will require replacement within the next 10 years or sooner if conditions warrant. We recommend that in the future the culvert be replaced with a new 16 m long, 2230 mm x 1700 mm aluminized corrugated steel pipe arch complete with rip rap end walls with filter fabric underlay, providing a minimum 7.3 m wide gravel surface.

Bridge No. 19: Station 3+167 Ryan A. LaBute (Roll No. 570-44000)

A 12 m long, 600 mm diameter corrugated steel pipe with rip rap/small concrete block end protection and a gravel driveway provides secondary access to this property. A culvert was not shown at this location on the profile in the 1987 report, its origin is unknown.

We recommend that this culvert be removed before work along the drain commences. This culvert is deficient in hydraulic capacity, and the property owner has requested that the culvert be removed since the primary access is available from Shawnee Road.

Bridge No. 20: Station 3+214 Town of Tecumseh (Shawnee Road)

A 12 m long 760 mm diameter corrugated steel pipe and asphalt roadway provides a road crossing. A 900 mm diameter corrugated steel pipe catch basin exists on the upstream end of the culvert on the east side of Shawnee Road. The outlet of the pipe on the west side of Shawnee Road has rip rap end protection. A culvert was shown at this location on the profile in the 1987 report. This culvert was determined to be in good condition, and to have adequate capacity to convey the flows expected to flow to this culvert during the 5 year design storm, which is considered appropriate for local road crossings. This assessment considers the limited capacity of the Shawnee Road Drain which consist of concrete tile with a maximum diameter of 300 mm diameter. The Shawnee Road Drain outlets into the upstream 900 mm diameter CSP catch basin of Bridge No. 20.



We anticipate that this culvert will require replacement within the next 10 years or sooner if conditions warrant. We recommend that in the future the culvert be replaced with a new 12 m long, 750 mm polymer laminated corrugated steel pipe complete, providing a minimum 6.0 m wide driveable asphalt surface. We recommend new rip rap end walls be installed on the downstream end of the culvert, and that the catch basin located on the upstream end be replaced and all existing pipes be reconnected to the new catch basin.

NextStar Battery Production Facility Working Corridor

Spreading of material will not be permitted over the lands south of the drain between Station 1+109 and Station 2+116 due to the change in land use. We recommend drain spoils be trucked away for the recommended works and for future maintenance at the cost of the abutting landowner. Alternatively, the abutting landowner may request that these drain spoils remain on-site.

Existing Conditions and Recommendations (Gouin Drain Branch North & South)

Landowners in the upper reaches of the drain within the residential subdivision are experiencing rear yard drainage issues, which may be in part due to the condition of the drain downstream and in part due to the poor condition of the portion of Gouin Drain that was altered during the Corbi Development in 1997. In addition, during the January 22, 2020 PIC, the residents noted that the rear yard drainage is not consistent. Some residents have catch basins along the drain, some have rear yard drainage installed during the subdivision construction and some have both. We recommend the existing Gouin Drain alignment, which exists within the rear yards of the properties fronting the east side of Corbi Lane, be abandoned and replaced by the existing storm sewers along Corbi Lane, as shown on the plans herein. We find the existing storm sewers to be incorporated as the new Gouin Drain alignment have hydraulic capacity to convey the 5 year design storm event.

To service the rear yards of the lands on the east side of Corbi Lane and on the west side of Shawnee Road, two new branch drains are proposed and shall henceforth be known as Gouin Drain Branch North and Gouin Drain Branch South. The north and south branch shall be located along the same alignment as the previous Gouin Drain.



The Gouin Drain Branch North shall drain northerly into the 1500 mm diameter municipal storm sewer beneath Gouin Street, and continue westerly, incorporating a section of 1500 mm diameter storm sewer. The north branch outlet will be to the Gouin Drain at MH1, as defined on the plans herein.

A gazebo and shed exist on the properties Mun. No. 1800 and 1806 Corbi Lane, respectively, which lie over the rear yard drain which consists of 300 mm diameter and 1050 mm diameter pipe. We recommend the deteriorated 1050 mm diameter CSP remain in place, as not to disturb these overlying backyard structures, and a 300 mm diameter HDPE pipe be slip-lined through the 1050 mm diameter pipe for its entire length and the voids between the pipes be filled with non-shrink concrete grout. The concrete grout will prevent a full collapse of the deteriorated 1050 mm diameter pipe and help maintain the integrity of the foundations of the backyard structures.

In order to provide all lands along the drain access to the Gouin Drain Branch North, two additional catch basin structures are recommended on properties Mun. No. 1800 and 1806 Corbi Lane. The catch basin maintenance hole on property Mun. No. 1812 Corbi Lane will be required to be removed in order to slip-line the existing 1050 mm diameter pipe. For reconnection of the existing upstream 300 mm diameter pipe to the new 300 mm diameter slip-lined pipe, a new catch basin is required due to the vertical misalignment of the said pipes.

The existing 300 mm diameter HDPE pipe draining south across the rear yards of Mun. Nos. 1836, 1840, 1846 and 1852 is in good condition and it is recommended to be incorporated as Gouin Drain Branch South, including associated catch basins. Its outlet will be into the 600 mm diameter concrete drain as part of the upper portion of the existing Gouin Drain. No work is currently proposed for this drain.

Allowances

In accordance with Sections 29 and 30 of the Drainage Act, we have made a determination of the amount to be paid for damages to the lands and for land used for the establishment of a working corridor and a permanent 1.0 m wide grass buffer strip adjacent to both banks of open section of the drain. The average land cost for the surrounding area used to calculate the value of land

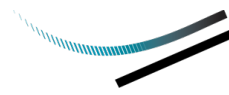

used is \$49,400 per hectare. Section 29 allowances total \$5,650.00. Section 29 allowances have not been provided for works completed on either Gouin Drain Branch South or Gouin Drain Branch North because the legal alignment of the drain had already been established on these lands. Likewise, no Section 29 allowances have been provided for the working corridor where historical drainage reports show allowances have already been provided.

Throughout the length of the work, the excavated material is to be disposed of as set out in the Special Provisions in Schedule 'F' herein. In accordance with Section 30 of the Drainage Act, we determined the amount to be paid to the owners for damages to lands and crops (if any) occasioned by the operation of equipment and the disposal of material excavated from the drain. In general, a 9 metre working corridor off of the drain top of bank has been considered for open drain, and a 6 metre working centered over closed drain. The allowance for damages is calculated at a rate of \$3,707 per hectare, (\$1,500 per acre). A secondary working corridor has also been specified to provide access to drain repairs and have been calculated at a half rate, equivalent to \$1,854 per hectare (\$750 per acre). Section 30 allowances total \$2,500.00. Backyards that are to be disturbed from the recommended works are to be restored, as such no Section 30 allowances have been provided.

Cost Estimate

Based on our review of the history, the information obtained during the site meetings and our examination and analysis of the survey data, we recommend that the Gouin Drain and Gouin Drain Branch North & South be repaired and improved as described below:

Item	Description	Amount
	GOUIN DRAIN	
	<u>OPEN DRAIN WORK</u>	
1.	Brushing of the drain including the disposal by burning on-site or removal off-site with trimming and/or removal of existing trees as required to accommodate the drainage works, as follows:	
	a) Light brushing between Stations 0+000 and 0+400, Stations 0+520 and 0+670, and Stations 1+032 and 2+116. Work includes	\$10,600.00



Item	Description	Amount
	temporary removal of approximately 210 metres of chain-link fence to access the drain, and restoration to existing conditions.	
	b) Medium brushing between Stations 2+116 and 2+758 (completed August 2020). <i>This item has been completed by the Town. It is not to be included when tendering the work for construction.</i>	\$6,500.00
2.	Excavation, levelling, and trucking of excavated materials works, as follows:	
	a) Drain deepening, as follows:	
	i) Station 0+172 to Station 1+010, totalling approximately 838 lineal metres of drain and approximately 1,600 m ³ of material.	\$21,600.00
	b) Excavation of drain bottom only, as follows:	
	i) Station 1+010 to Station 2+758, totalling approximately 1,748 lineal metres of drain and approximately 1,390 m ³ of material.	\$18,750.00
	ii) Station 3+128 to Station 3+208, totalling approximately 80 lineal metres of drain and approximately 25 m ³ of material.	\$700.00
	c) Trucking and disposal of excavated materials off-site, as follows:	
	i) Stations 1+109 to Station 2+116, totalling approximately 880 m ³ of material.	\$35,200.00
	ii) Stations 3+128 to Station 3+208, totalling approximately 25 m ³ of material.	\$1,000.00
	d) Levelling of excavated materials, as follows:	
	i) Station 1+010 to Station 1+109, totalling approximately 99 lineal metres of drain and approximately 10 m ³ of material.	\$250.00

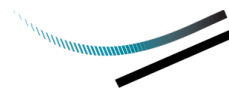

Item	Description	Amount
	ii) Station 2+116 to Station 2+758, totalling approximately 642 lineal metres of drain and approximately 500 m ³ of material.	\$2,750.00
3.	Seeding of grass buffer strips, as follows:	
	a) Seeding of 1.0 m wide grass buffer strip beyond the top of bank on the south side of the drain from Station 1+032 to Station 2+107 (approximately 1,080 m ²).	\$6,100.00
	b) Seeding of 1.0 m wide grass buffer strip beyond the top of bank on the north and south side of the drain from Station 2+122 to Station 2+680 (approximately 1,120 m ²).	\$6,300.00
	c) Seeding of 1.0 m wide grass buffer strip beyond the top of bank on the west side of the drain from Station 2+680 to Station 2+758 (approximately 80 m ²).	\$450.00
	d) Seeding of 1.0 m wide grass buffer strip beyond the top of bank on the north and south side of the drain from Station 3+128 to Station 3+208 (approximately 160 m ²).	\$900.00
4.	Private access bridge cleaning works, as follows:	
	a) Bridges No. 6, 7, 14, 15,16, 17, 18	\$7,000.00
5.	Removal of access bridges, as follows:	
	a) <u>Bridge No. 8 – Station 1+278 – City of Windsor (Roll No. 090-040-00103)</u> – The work is to include removal and disposal of existing 9.7 m long, 2240 mm x 1630 mm corrugated steel pipe arch as well as the existing bagged concrete headwalls and gravel driveway. Complete with grading and seeding of the drain banks, site clean-up and restoration within the working area.	\$2,500.00
	b) <u>Bridge No. 9 – Station 1+442 – City of Windsor (Roll No. 090-040-00103)</u> – The	\$2,500.00



Item	Description	Amount
	work is to include removal and disposal of existing 8.2 m long, 2240 mm x 1630 mm corrugated steel pipe arch as well as the bagged concrete headwalls and gravel driveway. Complete with grading and seeding of the drain banks, site clean-up and restoration within the working area.	
	c) <u>Bridge No. 10 – Station 1+646 – City of Windsor (Roll No. 090-040-00103)</u> – The work is to include removal and disposal of existing 7.8 m long, 2240 mm x 1630 mm corrugated steel pipe arch as well as the existing concrete headwalls and gravel driveway. Complete with grading and seeding of the drain banks, site clean-up and restoration within the working area.	\$2,500.00
	d) <u>Bridge No. 19 – Station 3+167 – Ryan A. LaBute (Roll No. 570-44000)</u> – The work is to include removal and disposal of existing 12 m long, 600 mm diameter corrugated steel pipe as well as the existing with rip rap and gravel driveway. Complete with grading and seeding of the drain banks, site clean-up and restoration within the working area.	\$1,500.00
6.	Stone erosion protection (SEP) works, as follows:	
	a) Station 1+104 – Supply and install 10 m ² (300 mm thick) of stone erosion protection (SEP) including new filter fabric underlay at the location of surface inlet swale on south side.	\$800.00
	b) Station 1+376 – Supply and install 15 m ² (300 mm thick) of stone erosion protection (SEP) including new filter fabric underlay at the location of surface inlet swale on south side.	\$1,250.00



Item	Description	Amount
	c) Station 1+549 – Supply and install 10 m ² (300 mm thick) of stone erosion protection (SEP) including new filter fabric underlay at the location of surface inlet swale on south side.	\$800.00
	d) Station 1+751 – Supply and install 10 m ² (300 mm thick) of stone erosion protection (SEP) including new filter fabric underlay at the location of surface inlet swale on south side.	\$800.00
	e) Station 2+162 – Supply and install 5 m ² (300 mm thick) of stone erosion protection (SEP) including new filter fabric underlay at the location of surface inlet swale on south side.	\$450.00
	f) Station 2+275 – Supply and install 20 m ² (300 mm thick) of stone erosion protection (SEP) including new filter fabric underlay at the location of surface inlet swale on north and south side.	\$1,600.00
	g) Station 2+363 – Supply and install 20 m ² (300 mm thick) of stone erosion protection (SEP) including new filter fabric underlay at the location of surface inlet swale on north and south side.	\$1,600.00
	h) Station 2+452 – Supply and install 30 m ² (300 mm thick) of stone erosion protection (SEP) including new filter fabric underlay at the location of surface inlet swale on north and south side.	\$2,400.00
	i) Station 2+572 – Supply and install 30 m ² (300 mm thick) of stone erosion protection (SEP) including new filter fabric underlay at the location of surface inlet swale on north and south side.	\$2,400.00
7.	Temporary Silt Control Measures During Construction	<u>\$1,200.00</u>

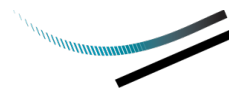

Item	Description	Amount
	SUB-TOTAL – EXCLUDING SECTION 26 COSTS	\$140,400.00
8.	Allowances under Sections 29 and 30	\$8,150.00
9.	Survey, Report, Assessment and Final Inspection (cost portion)	
	a) Soil Characterization Report and Environmental Review	\$29,600.00
	b) Future replacements	\$15,000.00
	c) Survey, remainder of report, final inspection	\$37,100.00
10.	Expenses and incidentals (cost portion)	\$1,800.00
11.	ERCA application review and permit fee	<u>\$800.00</u>
	TOTAL – EXCLUDING SECTION 26 COSTS	\$232,850.00
	SECTION 26 NON PRO-RATEABLE COSTS	
12.	Trucking of excavated materials works, as follows:	
	a) Trucking and landfilling of contaminated excavated materials off-site, as follows:	
	i) Station 0+162 to Station 0+250, totalling approximately 45 m ³ of material.	\$6,450.00
	ii) Station 0+470 to Station 1+010, totalling approximately 1,005 m ³ of material.	\$143,000.00
	b) Trucking of excavated materials off-site to a site capable of receiving soils meeting the Table 3.1 RPI and/or 3.1 ICC ESWS that has a salt-parameter exemption, as follows:	
	i) Station 0+250 to Station 0+470, totalling approximately 550 m ³ of material.	\$22,000.00
13.	Stone erosion protection (SEP) works, as follows:	
	a) Station 0+098 – Supply and install 15 m ² (300 mm thick) of stone erosion protection (SEP) including new filter fabric underlay at the location of washout on south drain bank.	\$1,250.00
14.	Road bridge cleaning works, as follows:	
	a) Cleaning of Bridge No. 5 – Station 1+020 19	\$1,000.00



Item	Description	Amount
	m long, 1520 mm diameter corrugated steel pipe (CSP) road culvert.	
	b) Cleaning of Bridge No. 13 – Station 2+116 15.6 m long, 2230 mm x 1700 mm corrugated steel pipe arch (CSPA) road culvert.	\$500.00
	c) Cleaning of Bridge No. 20 – Station 3+214 12 m long, 760 mm diameter corrugated steel pipe (CSP) road culvert.	\$500.00
15.	Bridge works, as follows:	
	a) <u>Bridge No. 1 – Station 0+200 (Enbridge Gas, Enwin Water & Bell Canada)</u> – Removal and disposal of existing 28 m long twin 1370 mm x 1000 mm CSPA, existing end walls and backfill off-site that are not suitable for native backfill. Installation of a new 32 m long, 2500 mm x 1830 mm corrugated steel pipe arch (CSPA). Clear stone bedding material beneath pipe minimum 150 mm thickness, up to pipe springline (approximately 110 tonnes). Clean native or imported clean native backfill material from springline of pipe culvert to the underside of grassed driveway (approximately 300 m ³). Topsoil (approximately 15 m ³), fine grading and seeding (approximately 230 m ²). Sloping stone end walls and lining of drain bottom with stone erosion protection to allow for excavation below proposed grade line at upstream and downstream ends of culvert (approximately 130 m ²). Removal and restoration of fence to existing conditions. Cost includes installation of all necessary supports for existing utilities necessary	\$86,000.00



Item	Description	Amount
	during construction and third party inspection.	
	b) <u>Bridge No. 3 – Station 0+825 (Enwin Powerlines)</u> – Removal and disposal of existing 7 m long, twin 1520 mm x 1160 mm CSPA, existing end walls and backfill off-site that are not suitable for native backfill. Installation of a new 16 m long, 2500 mm x 1830 mm corrugated steel pipe arch (CSPA). Clear stone bedding material minimum 150 mm beneath pipe, up to pipe springline (approximately 75 tonnes). Granular 'B' backfill up to the underside of Granular 'A' driveway material (approximately 115 tonnes). Native material backfill beyond edges of driveway to construct the 0.5 m wide native buffer strips (approximately 30 m ³). Granular 'A' (crushed limestone) compacted driveway surface, minimum 200 mm thickness (approximately 40 tonnes). Sloping stone end walls and lining of drain bottom with stone erosion protection to allow for excavation below proposed grade line at upstream and downstream ends of culvert (approximately 85 m ²).	\$47,100.00
16.	Bridge repairs, as follows:	
	a) <u>Bridge No. 4 – Station 0+958 (City of Windsor)</u> – Lining of drain bottom and drain banks on downstream and upstream ends of bridge where drain bottom falls below design grade using stone erosion protection (300 mm thickness) (approximately 260 m ²) to be embedded into drain bottom.	\$20,600.00
17.	Removal of access bridges, as follows:	

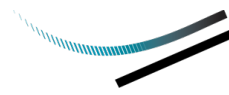

Item	Description	Amount
	a) <u>Bridge No. 2 – Station 0+534</u> – Removal and disposal of existing 6 m long twin 1900 mm x 1050 mm CSPA, existing end walls and backfill off-site. Complete with grading and seeding of the drain banks, site clean-up and restoration within the working area.	\$2,500.00
	SUB-TOTAL – SECTION 26 NON PRO-RATEABLE COSTS	\$330,900.00
18.	Survey, Daylighting Investigation, Report, Future Replacements, Assessment & Final Inspection (cost portion) <i>This item has been completed by the Town. It is not to be included when tendering the work for construction.</i>	<u>\$97,100.00</u>
	TOTAL – SECTION 26 NON PRO-RATEABLE COSTS	\$428,000.00
	TOTAL ESTIMATE – GOUIN DRAIN	\$660,850.00

Item	Description	Amount
	GOUIN DRAIN BRANCH NORTH	
	<u>CLOSED DRAIN WORK</u>	
1.	Work required within property Municipal No. 1800 Corbi Lane includes:	
	a) <u>Station 0+091A</u> - Supply and installation of one (1) new 600 mm x 600 mm precast concrete catch basin (denoted CB1) complete with cast iron heavy-duty grate as manufactured by Coldstream Concrete (or approved equal) and a minimum 300 mm deep sump. The grates shall be equipped with fasteners to secure grates to catch basins as supplied by the manufacturer. Work to include connection of all new and existing pipes and grouting of all voids	\$2,500.00

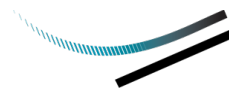

Item	Description	Amount
	around pipes with non-shrink concrete grout.	
	b) <u>Station 0+079A to Station 0+091A</u> - Supply and install approximately 12 metres of 300 mm diameter solid corrugated high density polyethylene (HDPE), smooth wall, 320 kPa pipe (Boss 2000 or approved equal) with bell and spigot joining system. Join pipe with existing 300 mm diameter HDPE pipe with Fernco coupler (or approved equal). Granular 'B' bedding beneath pipe, minimum 150 mm thickness and backfill up to springline of pipe (approximately 10 tonnes). Clean native backfill material from Granular 'B' to underside of top soil (approximately 27 m ³). Minimum 50 mm thick layer of top soil above native material, fine grade and seed. Work includes removal and disposal of existing 12 metre (approx.) 1050 mm diameter corrugated steel pipe (CSP). The Contractor shall supply and install temporary construction fencing along the designated working corridor.	\$6,300.00
	c) Reinstatement of fence and restoration of all disturbed areas to existing conditions.	\$950.00
2.	Work required within property Municipal No. 1806 Corbi Lane includes:	
	a) <u>Station 0+112.5A</u> - Supply and installation of one (1) new 600 mm x 600 mm precast concrete catch basin (denoted CB2) complete with cast iron heavy-duty grate as manufactured by Coldstream Concrete (or approved equal) and a minimum 300 mm deep sump. The grates shall be equipped with fasteners to secure grates to catch	\$3,000.00

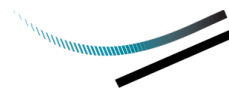

Item	Description	Amount
	<p>basins as supplied by the manufacturer. Remove and dispose a portion of existing 1050 mm diameter corrugated steel pipe (CSP) to accommodate installation of CB2. Work includes connection of all new and existing pipes and grouting of all voids around pipes with non-shrink concrete grout.</p>	
	<p>b) <u>Station 0+091A to Station 0+112.5A</u> - Supply and install approximately 21.5 metres of 300 mm diameter polyethylene (PE), smooth wall pipe. Work includes slipping new 300 mm diameter PE pipe into existing 1050 mm diameter corrugated steel pipe (CSP). The Contractor shall supply and install temporary construction fencing along the designated working corridor.</p>	\$5,300.00
	<p>c) Reinstatement of fence and restoration of all disturbed areas to existing conditions.</p>	\$1,150.00
3.	<p>Work required within property Municipal No. 1812 Corbi Lane includes:</p> <p>a) <u>Station 0+133A</u> – Remove and dispose of existing catch basin maintenance hole. Supply and installation of one (1) new 600 mm x 600 mm precast concrete catch basin (denoted CB3) complete with cast iron heavy-duty grate as manufactured by Coldstream Concrete (or approved equal) and a minimum 300 mm deep sump. The grates shall be equipped with fasteners to secure grates to catch basins as supplied by the manufacturer. Remove and dispose a portion of existing 1050 mm diameter corrugated steel pipe (CSP) to accommodate installation of CB3.</p>	\$2,750.00

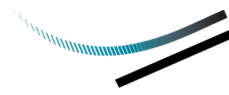

Item	Description	Amount
	Work includes connection of all new and existing pipes and grouting of all voids around pipes with non-shrink concrete grout.	
	a) <u>Station 0+112.5A to Station 0+133A</u> - Supply and install approximately 20.5 metres of 300 mm diameter solid corrugated high density polyethylene (HDPE), smooth wall, 320 kPa pipe (Boss 2000 or approved equal) with bell and spigot joining system. Work includes slipping new 300 mm diameter HDPE pipe into existing 1050 mm diameter corrugated steel pipe (CSP). The Contractor shall supply and install temporary construction fencing along the designated working corridor.	\$3,200.00
	b) Reinstatement of fence and restoration of all disturbed areas restored to existing conditions.	<u>\$750.00</u>
	SUB-TOTAL – EXCLUDING NON PRO-RATEABLE COSTS	\$25,900.00
4.	CCTV and works related to inspection of enclosed portion of the Gouin Drain, including flushing. <i>This item has been completed by the Town. It is not to be included when tendering the work for construction.</i>	\$7,250.00
5.	Survey, Report, Assessment and Final Inspection (cost portion)	\$6,350.00
6.	Expenses and incidentals (cost portion)	<u>\$500.00</u>
	TOTAL – EXCLUDING NON PRO-RATEABLE COSTS	\$40,000.00
	NON PRO-RATEABLE COSTS	
7.	Injection of non-shrink concrete grout to fill voids between the existing 1050 mm diameter	\$24,400.00

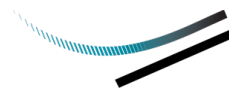

Item	Description	Amount
	corrugated steel pipe (CSP) and new 300 mm diameter high density polyethylene (HDPE) pipe between Station 0+091A and Station 0+133A (approximately 88 tonnes), ensuring the HDPE pipe does not shift within the CSP.	
	SUB-TOTAL – NON PRO-RATEABLE COSTS	\$24,400.00
8.	Survey, Report, Assessment & Final Inspection (cost portion)	<u>\$3,650.00</u>
	TOTAL – NON PRO-RATEABLE COSTS	\$28,050.00
	TOTAL ESTIMATE – GOUIN DRAIN BRANCH NORTH	\$68,050.00

Item	Description	Amount
	GOUIN DRAIN BRANCH SOUTH	
1.	Survey, Report, and Assessments	\$5,000.00
2.	Flushing of enclosed drain <i>This item has been completed by the Town. It is not to be included when tendering the work for construction.</i>	<u>\$1,950.00</u>
	TOTAL ESTIMATE – GOUIN DRAIN BRANCH SOUTH	\$6,950.00
	GRAND TOTAL ESTIMATE	\$736,350.00

The estimate provided in this report was prepared according to current materials and installation prices as of the date of this report. In the event of delays from the time of filing of the report by the Engineer to the time of tendering the work, it is understood that the estimate of cost is subject to inflation. The rate of inflation shall be calculated using the Consumer Price Index applied to the cost of construction from the date of the report to the date of tendering.

Should the Road Authority elect to construct the drainage works across their road right-of-ways (Section 26 increased cost items) with their own forces, as per Section 69 of the Drainage Act, R.S.O., 1990, the Road Authority shall

remain responsible for their allotment of costs for the preparation of this report as outlined in our estimate. Should the Road Authority elect not to undertake this work, the work items, as noted under Section 26 above, should be kept separate when tendering out the entire drainage works.

Assessment of Costs

The individual assessments are comprised of three (3) assessment components:

- i. Benefit (*advantages relating to the betterment of lands, roads, buildings, or other structures resulting from the improvement to the drain*).
- ii. Outlet Liability (*part of cost required to provide outlet for lands and roads*).
- iii. Special Benefit (*additional work or feature that may not affect function of the drain*).

Assessment Rationale - Gouin Drain Improvements

We have assessed the above estimated costs for the repair and improvement of the Gouin Drain against the affected lands and roads listing in Schedule 'C-1' under 'Benefit' and 'Outlet Liability'.

The above estimated costs have been assessed 25% as a Benefit assessment and 75% as an Outlet Liability assessment against all upstream lands and roads within the drainage area. This split was established in the 1987 report. Special Benefit assessments shown in Schedule 'C-1' and detailed in Schedule 'D-1' were derived as follows:

1. For tile main outlet repairs including stone erosion protection as required, at the location of the said main tile outlets, the Drainage Superintendent and/or Engineer may direct the contractor to make these repairs at the expense of the landowner. Private tile repairs shall be assessed 100% against the property on which the said tile exists.
2. Bank failure repairs caused by surface water inlets along the drain shall be assessed 100% to the abutting landowner. Where the surface water inlet is abutted by two properties, the cost of said repair shall be assessed 50% to each of the abutting landowners.

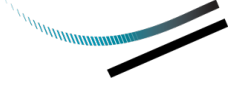
- 
3. All increased costs borne from the need to truck and dispose of excavated material off-site, or to truck excavated material within the working corridor, have been assessed to the abutting landowner.

We have assessed residential lands within the Gouin Drain drainage area of Concession 2, Lots 148, 149, and 150 as a block assessment, denoted as Block 'A.'

We have assessed the residential land within the Gouin Drain drainage area of Concession 1, Lots 124 and 126 as a block assessment, denoted as Block 'E.'

Assessment Rationale for Special Benefit Assessments (Bridges)

Special Benefit assessment shown in Schedule 'C-1' and detailed in Schedule 'D-1' were derived as follows:

1. Costs associated with the replacement of Bridge No. 1 has been assessed equally between Bell Canada (25%), Enbridge Gas (25%), Enwin Water (25%), and Enwin Powerlines (25%) and shall be a non-proratable assessment.
2. Costs associated with work for the removal of Bridge No. 2 have been assessed to the City of Windsor (100%) and shall be a non-proratable assessment.
3. Costs associated with work for the replacement of Bridge No. 3 have been assessed to Enwin Powerlines (100%) and shall be a non-proratable assessment.
4. An engineering cost portion of \$2,500.00 each for the design provisions on the future replacement of primary access Bridge Nos. 6, 14, 15, 17, & 18 has been assessed 50% against the abutting property and the remaining 50% as an Outlet assessment to the upstream lands and roads.
5. An engineering cost portion of \$2,500.00 each for the design provisions on the future replacement of Bridge No. 7 & 12 has been assessed 100% against the abutting property.
6. An engineering cost portion of \$3,500.00 each for the design provisions on the future replacement of Bridge No. 5 (Anchor Drive), Bridge No. 13 (Banwell Road), and Bridge No. 20 (Shawnee Road) has been assessed

100% against the owning Road Authorities under Section 26 of the Drainage Act and shall be a non-proratable assessment.

7. Costs associated with the removal of Bridge Nos. 8, 9 & 10 have been assessed to the abutting properties (City of Windsor) and shall be a non-proratable assessment.
8. Costs associated with the removal of Bridge No. 19 have been assessed to Roll No. 570-44000 (Ryan A. LaBute) and shall be a non-proratable assessment.

Assessment Rationale - Gouin Drain Branch North Improvements

We have assessed the above estimated costs for the repair and improvement of the Gouin Drain Branch North against the affected lands and roads listing in Schedule 'C-2' under 'Benefit' and 'Outlet Liability'.

The above estimated costs have been assessed 50% as an Outlet Liability assessment against all upstream lands and roads within the drainage area, and 50% Benefit assessment against the lands fronting the portion of drain requiring repair. Special Benefit assessments shown in Schedule 'C-2' and detailed in Schedule 'D-2' were derived as follows:

1. Increased costs associated with the replacement and rehabilitation of the existing 1050 mm diameter corrugated steel pipe (CSP) underneath the existing private structures positioned over the drain have been assessed to the Town of Tecumseh (100%). The supply and installation of non-shrink concrete grout to fill voids between existing 1050 mm diameter CSP and the proposed 300 mm diameter polyethylene (PE) pipe, as well as the CCTV inspection (excluding drain flushing costs) have been assessed as a non-proratable assessment. The remainder of the increased costs as a result of working within residential lands include pipe installation, temporary construction fencing, and restoration of landscaping damaged by the proposed works.

Assessment Rationale - Gouin Drain Branch South Improvements

We have assessed the above estimated costs for the engineering fees and the previously completed drain flushing work associated with the Gouin Drain Branch South against the affected lands and roads listing in Schedule 'C-3' under 'Benefit' and 'Outlet Liability'.

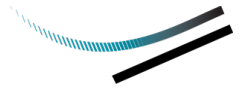



The above estimated costs have been assessed 50% as an Outlet Liability assessment against all upstream lands within the drainage area and 50% as a Benefit assessment. All lands within the Gouin Drain Branch South drainage area have been assessed as block assessments, denoted Block 'D.'

Utilities

It may become necessary to temporarily or permanently relocate utilities that may conflict with the construction recommended under this report. In accordance with Section 26 of the Drainage Act, we assess any relocation cost against the public utility having jurisdiction. Under Section 69 of the Drainage Act, the public utility is at liberty to do the work with its own forces, but if it should not exercise this option within a reasonable time, the Municipality will arrange to have this work completed and the costs will be charged to the appropriate public utility.

Future Maintenance (Gouin Drain within Town of Tecumseh Sta. 2+162 to Sta. 3+286)

After completion, the Gouin Drain shall be maintained by the Town of Tecumseh at the expense of the lands and road herein assessed in Schedule 'E-1', and in the same relative proportions subject, of course, to any variations that may be made under the authority of the Drainage Act. The assessments are based on an arbitrary amount of \$10,000.00.

Future Maintenance (Gouin Drain within City of Windsor Sta. 0+000 to Sta. 2+162)

After completion, the Gouin Drain shall be maintained by the City of Windsor at the expense of the lands and road herein assessed in Schedule 'E-2', and in the same relative proportions subject, of course, to any variations that may be made under the authority of the Drainage Act. The assessments are based on an arbitrary amount of \$10,000.00.

The cost associated with trucking and disposal of the drain between Station 1+109 to Station 2+116 is to be assessed 100% to the abutting landowner.

Future Maintenance (Private Access Bridges within Town of Tecumseh)

We recommend that future work of repair and maintenance of the Gouin Drain private access bridges be carried out by the Town of Tecumseh at the expense of the property or properties accessed by the bridge and of the lands

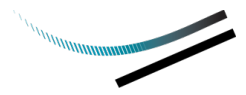

and roads shown in Schedule 'E-3,' but only to those properties located upstream of each bridge.

Part of the maintenance cost of each bridge will be assessed as a Special Benefit assessment against the property or properties served by the bridge as outlined in the table below. The remainder of the maintenance cost will be assessed as Outlet assessment only to the lands and roads upstream of each bridge prorated to the assessments shown in Schedule 'E-3.'

Schedule 'E-3' represents all the lands and roads upstream of Bridge No. 14 and is applicable to other primary access bridges located further upstream by including only those properties that are upstream of the said bridge. The assessment is based on an arbitrary amount of \$10,000.00 of future access bridge maintenance costs.

The future removal cost for Bridge No. 16, will be assessed 100% to the land owner.

Future Maintenance (Private Access Bridges within City of Windsor)

We recommend that future work of repair and maintenance of the Gouin Drain private access bridges be carried out by the City of Windsor at the expense of the property or properties accessed by the bridge and of the lands and roads shown in Schedule 'E-4,' but only to those properties located upstream of each bridge.

Part of the maintenance cost of each bridge will be assessed as a Special Benefit assessment against the property or properties served by the bridge as outlined in the table below. The remainder of the maintenance cost will be assessed as Outlet assessment only to the lands and roads upstream of each bridge prorated to the assessments shown in Schedule 'E-4.'

Schedule 'E-4' represents all the lands and roads upstream of Bridge No. 6 and is applicable to other primary access bridges located further upstream by including only those properties that are upstream of the said bridge. The assessment is based on an arbitrary amount of \$10,000.00 of future access bridge maintenance costs.

As per City of Windsor Council Resolution CR388/2007 and in accordance with the City of Windsor Act, assessments of cost to landowners for the maintenance of the Gouin Drain, excluding bridges, will be paid for from the

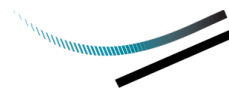

City of Windsor general tax or sewer surcharge levy provided excavated material may be spread on the abutting lands. Costs assessed to landowners within the City of Windsor for bridge maintenance will be paid by the benefiting landowner according to this report.

The division between Special Benefit and Outlet assessment for each bridge shall be as follows:

Bridge No.	Type	Owner(s)	Special Benefit	Outlet
<u>City of Windsor</u>				
1	Utility Access	Bell Canada (Section 26) Enbridge Gas (Section 26) Enwin Water (Section 26) Enwin Powerlines (Section 26)	25% 25% 25% 25%	0%
3	Utility Access	Enwin Powerlines (Section 26)	100%	0%
4	Road	City of Windsor Road Authority (Section 26)	100%	0%
5	Road	City of Windsor Road Authority (Section 26)	100%	0%
6	Primary	Gary Barbesin Roll No. 070-650-01303	50%	50%
7	Secondary	Jamison Laboratories Ltd Roll No. 070-650-01351	100%	0%
13	Road	City of Windsor Road Authority (Section 26)	100%	0%
<u>Town of Tecumseh</u>				
14	Primary	507822 Ontario Inc. First Mirage Management Inc. Roll No. 570-46201	50%	50%
15	Primary	1486044 Ontario Ltd. Roll No. 570-45950	50%	50%
16	Secondary	1486044 Ontario Ltd. Roll No. 570-45950	100%	0%
17	Primary	1486044 Ontario Ltd. Roll No. 570-45930	50%	50%

18	Primary	2034053 Ontario Ltd. Roll No. 570-45902	50%	50%
20	Road	Town of Tecumseh Road Authority (Section 26)	100%	0%

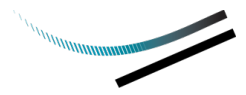

Future Maintenance (Gouin Drain Branch North)

The Gouin Drain Branch North shall be maintained by the Town of Tecumseh at the expense of the lands and roads herein assessed according to the following:

- Cost of future work completed between Station 0+000A and Station 0+064A, shall be herein assessed in Schedule ‘E-5’ and in the same relative proportions subject to any variations that may be made under the authority of the Drainage Act. The assessments are based on an arbitrary amount of \$10,000.00.
- Cost of future work completed between Station 0+064A and Station 0+198A shall be herein assessed in the same relative proportions as shown in Schedule ‘E-6.’ This is subject, of course, to any variations that may be made under the authority of the Drainage Act. The assessments are based on an arbitrary amount of \$10,000.00.

The drainage area of Gouin Drain Branch North includes residential lands and roads that are serviced by a municipal storm sewer network that discharges into the drain at MH5 (Station 0+064A). All upstream lands and roads have been included as a block assessment denoted Block ‘B’ for the purposes of future assessment of the section of drain downstream of Station 0+064A.

Future Maintenance (Gouin Drain Branch South)

The Gouin Drain Branch South shall be maintained by the Town of Tecumseh at the expense of the lands herein assessed in Schedule ‘E-7,’ and in the same relative proportions subject to any variations that may be made under the authority of the Drainage Act.

Drawings and Specifications

Attached to this report is Schedule ‘F’, which are Specifications setting out the details of the recommended works and Schedule ‘G’ which represent the drawings that are attached to this report.



Page 1 of 21 – Overall Watershed Plan
Page 2 of 21 – Plan A & B
Page 3 of 21 – Plan C
Page 4 of 21 – Plan D
Page 5 of 21 – Plan E
Page 6 of 21 – Profile Station 0+000 to Station 1+010
Page 7 of 21 – Profile Station 1+010 to Station 2+160
Page 8 of 21 – Profile Station 2+160 to Station 3+286
Page 9 of 21 – Profile Gouin Drain Branch North
Page 10 of 21 – Profile Gouin Drain Branch South & Branch Drain
Details
Page 11 of 21 – Cross Sections Station 0+000 to Station 1+010
Page 12 of 21 – Cross Sections Station 1+010 to Station 3+286
Page 13 of 21 – Bridge Design Information
Page 14 of 21 – Bridge No. 1 Replacement
Page 15 of 21 – Bridge No. 3 Replacement
Page 16 of 21 – Future Bridge No. 5 Replacement
Page 17 of 21 – Future Bridge No. 7 Replacement
Page 18 of 21 – Future Bridge No. 6, 14, 15, 17, 18 Replacement
Page 19 of 21 – Future Bridge No. 13 Replacement
Page 20 of 21 – Future Bridge No. 20 Replacement
Page 21 of 21 – Miscellaneous Details

Approvals

The construction and/or improvement to a drainage works, including repair and maintenance activities, and all operations connected therewith are subject to the approval, inspection, by-laws and regulations of all Municipal, Provincial, Federal and other authorities having jurisdiction in respect to any matters embraced by the proposed works. Prior to any construction or maintenance works, the Municipality or proponent designated on the Municipality's behalf shall obtain all required approvals/permits and confirm any construction limitations including timing windows, mitigation/off-setting measures, standard practices or any other limitations related to in-stream works.

Grants

In accordance with the provisions of Sections 85, 86 and 87 of the Drainage Act, a grant in the amount of 33–1/3 percent of the assessment eligible for a grant may be made in respect to the assessment made under this report upon privately owned lands used for agricultural purposes. The assessments levied against privately owned agricultural land must also satisfy all other eligibility criteria set out in the Agricultural Drainage Infrastructure Program policies. Most of the privately owned lands are used for agricultural purposes and are eligible under the A.D.I.P. policies. We are not aware of any lateral drains involved in this work that would not be eligible for a grant. We recommend that application be made to the Ontario Ministry of Agriculture and Food in accordance with Section 88 of the Drainage Act, for this grant, as well as for all other grants for which this work may be eligible.

Respectfully submitted,



DILLON CONSULTING LIMITED

Mark D. Hernandez, P.Eng.

MDH:jrb

Our File: 17-6773



SCHEDULE "A-1"

MEETING MINUTES



Subject: Gouin Drain- Onsite Meeting Minutes
 Date and Time: Thursday February 8th 2018
 Location: Town of Tecumseh Council Chambers, 917 Lesperance Rd, Town of Tecumseh
 Our File: 17-6773

Attendees

Mark Hernandez	Dillon Consulting
Sam Paglia	Town of Tecumseh
Sign-in sheet attached	

Notes

<u>Item</u>	<u>Discussion</u>	<u>Action By</u>
1.	General Information Regarding The Drainage Act <ul style="list-style-type: none"> • The Drainage act is a Provincial Act that is the responsibility of the municipal government to implement • The act is over 100 years old and can be found on E-Laws • The Act is a user based system, this is dissimilar to municipal sewers. • The drainage process is as follows: <ul style="list-style-type: none"> ○ A request is submitted ○ The Engineer is appointed by the Municipality ○ Site Meeting held ○ Survey is completed ○ The Report is prepared ○ PIC is held (not required by the Act) ○ A meeting is set for Consideration (technical aspects of report) ○ Court of Revisions (cost aspects of report) • The purpose of the site meeting is to gather information from landowners who can provide feedback about the performance of the drain as well as provide other information regarding the drain and watershed. 	INFO. INFO. INFO. INFO.

2. Payment
- Drain Cleanouts INFO.
 - These costs are typically assessed for benefit and outlet per the act. The assessment is based on how much water is sent down the drain and how much of the drain is used.
 - Culvert Replacements INFO.
 - When a replacement culverts is required the cost assessment is usually split 50/50.
 - If a new culvert is required the landowner is typically assessed 100% of the cost.
 - Special Benefit Assessment INFO.
 - These are items that do not affect the function of the drain, these items could include: different headwalls, longer pipes, etc.
 - The Engineer determines the assessment. Each assessment will include details for each property that falls within the watershed. INFO.
 - Grants are available for properties that have a “Farm Class Tax Rate” INFO.
 - The municipality will bill the landowners after the work is complete for their net assessment. INFO.
3. Report Expectations
- All landowners will receive copies of the draft report with their notice for the PIC, Meeting to Consider and the Court of Revision. INFO.
Reports generally contain:
 - Background information about the request
 - History on the drain
 - Watershed
 - Drawings
 - Design considerations
 - Recommended work
 - Cost estimate
 - Meeting Minutes
 - Assessments including future maintenance provisions
 - Specifications
4. Affects during Construction
- Typically only landowners along the drain will be affected by construction. INFO.
 - Working corridors are defined within the report.
 - Work shall result in creating either the same or better level or INFO.

- service. INFO.
- The quality of work is typically monitored during construction by the Drainage Superintendent.
 - The engineer is required to complete a final inspection.
5. Environmental Requirements INFO.
- Department of Fisheries and Oceans, Ministry of Natural Resources and Forestry and Essex Regional Conservation Authority, regulations must be followed and permits obtained by the municipality as required.
6. Next Steps INFO.
- Topographical survey will be completed and then the preparation of the report will commence INFO.
 - PIC Meeting will be held. A notice and draft report will be provided in advance. INFO.
INFO.
 - Board Meetings
7. Question from landowner INFO.
1. Nature of request- request came from upstream landowners who have concerns with respect to the standing water/poor performance of the drain
 2. Can upstream section of the Gouin Drain in the residential area be abandoned? - The municipal drain allows for the right to access and maintain the drain. The municipality does not have the easements/access rights required to complete this work if the drain is abandoned.

Errors and/or Omissions

These minutes were prepared by Kristine Wilkinson E.I.T., who should be notified of any errors and/or omissions.

SCHEDULE "A-2"

MEETING MINUTES



Subject: Gouin Drain- Onsite Meeting Minutes
 Date and Time: Friday April 6th 2018
 Location: Town of Tecumseh Council Chambers, 917 Lesperance Rd, Town of Tecumseh
 Our File: 17-6773

Attendees

Mark Hernandez	Dillon Consulting
Kristine Wilkinson	Dillon Consulting
Sam Paglia	Town of Tecumseh
Anna Godo	City of Windsor

Notes

<u>Item</u>	<u>Discussion</u>	<u>Action By</u>
1.	This meeting was held specifically for the benefit of landowners within the City of Windsor, who had not received a copy of the invitation for the 8 February 2018 meeting. No landowners attended the meeting.	INFO.

Errors and/or Omissions

These minutes were prepared by Kristine Wilkinson E.I.T., who should be notified of any errors and/or omissions.

SCHEDULE "A-3"

MEETING MINUTES



Subject: Gouin Drain Branch North & South - Onsite Meeting Minutes
 Date and Time: 5:30 pm, Wednesday January 22nd, 2020
 Location: Tecumseh Arena, Horwood Room, 12021 McNorton Street,
 Tecumseh, Ontario
 Our File: 17-6773

Attendees

Mark Hernandez	Dillon Consulting
Kristine Wilkinson	Dillon Consulting
Sam Paglia	Town of Tecumseh
Troy Meloche	Landowner (1800 Corbi)
John Crispial	Landowner (1806 Corbi)
Brian Houston	Landowner (1812 Corbi)
David	Landowner (1818 Corbi)
--	Landowner (1824 Corbi)
Milica Spojadinovic	Landowner (1830 Corbi)
Ace	Landowner (1836 Corbi)
Massimo	Landowner (1840 Corbi)
Verica Cheward	Landowner (1852 Corbi)
Angelo Veselli	Landowner (11961 Shawnee)
--	Landowner (1803 Shawnee)
Guiseppe Lunghi	Landowner (1809 Shawnee)
--	Landowner (1815 Shawnee)
Andre Viselli	Landowner (1827 Shawnee)
--	Landowner (1829 Shawnee)
Kevin Cheng	Landowner (1833 Shawnee)
--	Landowner (1835 Shawnee)

Notes

<u>Item</u>	<u>Discussion</u>	<u>Action By</u>
1.	Special meeting of landowners was held to gather additional information of the existing drainage of lands between Corbi Lane and Shawnee Road. Table 1 below provides a summary of the existing drainage conditions as described by the landowners.	N/A

Table 1: Description of Drainage of Gouin Drain Branch North & South

Address	Description of Drainage
1800 Corbi	<ul style="list-style-type: none"> • 1 Rear Yard catch basin (may have second drain hidden under the large deck). • Flows very slow during large rain events (yard becomes very saturated) • Basement has a sump pump that goes to the front of the house
1806 Corbi	<ul style="list-style-type: none"> • Rear yard catch basin flows to the front of the street • No flooding issue
1812 Corbi	<ul style="list-style-type: none"> • 2 Rear yard catch basins (the smaller diameter CB flows to the front of the house with the sump pump flows, and the other discharges to the Gouin Drain) • 2 downspouts are tied in to both the front drainage and the back
1818 Corbi	<ul style="list-style-type: none"> • 1 Rear Yard Catch basin. • Basement has a sump pump that goes to the front of the house
1824 Corbi	<ul style="list-style-type: none"> • 2 Rear Yard catch basins (one goes to the front of the house the other flows to the rear yard) • Downspouts are disconnected
1830 Corbi	<ul style="list-style-type: none"> • 1 Rear yard catch basin (flows to the Gouin Drains) • No issues while raining • Basement sump pump
1836 Corbi	<ul style="list-style-type: none"> • 2 Rear yard catch basins about 15 feet apart. Large CB is the municipal drain & the small CB goes to the front of the house • No flooding issues • Basement has a sump pump that goes to the front of the house
1840 Corbi	<ul style="list-style-type: none"> • 1 Rear yard catch basin, goes to municipal drain. • No issues during rain events
1852 Corbi	<ul style="list-style-type: none"> • Rear yard catch basin allows for good flow
11961 Gouin	<ul style="list-style-type: none"> • Spoke with son Tony 519-566-4955- sump pump drains into the
1803 Shawnee	<ul style="list-style-type: none"> • Sump pump from the house goes to the back of the house then through the neighbours yard and into the Gouin (5inch pipe) • No issues when it rains
1809 Shawnee	<ul style="list-style-type: none"> • No rear yard catch basin • No drainage problems, his lot is elevated compared to neighbours
1815 Shawnee	<ul style="list-style-type: none"> • Bad Flooding in rear yard (no where for water to go)
1827 Shawnee	<ul style="list-style-type: none"> • No rear yard catch basin • Rear yard surface waters flow into low lying lands of 11961 Gouin and then into the drain

1829 Shawnee	<ul style="list-style-type: none">• Water flows west in the backyard towards the municipal drain
1833 Shawnee	<ul style="list-style-type: none">• 6 inch from evesthrough to rear to the drain. Rear yard is lower than front (no flooding in normal rain events)
1835 Shawnee	<ul style="list-style-type: none">• No issues, water in open drain is typically not very full

Errors and/or Omissions

These minutes were prepared by Kristine Wilkinson E.I.T., who should be notified of any errors and/or omissions.

SCHEDULE "A-4"

MEETING MINUTES



Subject: Gouin Drain Public Information Centre Meeting
 Date and Time: 1:30 pm, April 28, 2022
 Location: Virtual Zoom Call hosted by the Town of Tecumseh
 Our File: 17-6773

Attendees

Sam Paglia	Town of Tecumseh
John Henderson	Town of Tecumseh
Alessia Mussio	Town of Tecumseh
Andrew Dowie	City of Windsor
Garry Rossi	Windsor Utilities Commission/Enwin
Oliver Moir	Dillon Consulting Limited
Mark Hernandez	Dillon Consulting Limited
Wendy Belisle	Dillon Consulting Limited
Domenic Viselli	Landowner
Gary Coles	Landowner
Brian Houston	Landowner
Dan Omahen	Landowner
Joe Bachetti	Landowner
J. Andkilde	Landowner
R. Danby	Landowner
John	Landowner
Kevin	Landowner
Cathy	Landowner

Notes

<u>Item</u>	<u>Discussion</u>	<u>Action By</u>
	Meeting Introduction:	
1.	Sam Paglia introduced Town staff and Engineers and provided an explanation of the Drainage Act process. Sam stated that everyone in the watershed will receive a copy of the Final report and a date for the Meeting to Consider.	INFO.
2.	Oliver Moir presented the report and explained the current state of the drain and the proposed work to be completed as well as an overview of the assessment schedules, block assessments, working corridors. Oliver noted that an additional secondary	INFO.

working corridor is required for a section of drain and that it would be included in the finalized report.

- Sam clarified block assessments and fairness and also to provide any additional questions once they receive final report so they can be resolved before adoption of the report. The average range of assessments is \$107-400. INFO.

3. Through landowner questions of the assessments, it was realized that assessment of cost through the use of block assessments resulted in an unfair distribution of costs among the landowners of Block C for the Gouin Drain Branch North. Mark Hernandez recognized that a regular assessment would be more appropriate. The finalized report will reflect this change. INFO.

Questions & Answer Period:

4. Domenic Viselli asked for an explanation of his assessment. He also inquired about his son's property. INFO.

- Sam Paglia explained his assessment and told the audience that the assessments are based on the cost estimate, and the final assessments will be based on the tendered prices. INFO.

- Sam Paglia stated that typically the watershed boundary is established by historical reports and rarely do they change. INFO.

5. Gary Coles spoke to the function of the drain and bridge and culverts blocked and he built a clay berm to stop neighbours flow. Will maintenance relieve these issues? Is the east side of Shawnee Road in the watershed? INFO.

- Sam Paglia spoke to the difference between a road side drain, private ditches and municipal drains. He also explained common law. INFO.

6. Gary Coles stated maintenance is needed and culverts need to be flushed. INFO.

- Sam Paglia stated the drain will be put on a regular/annual brushing and/or cleaning and landowners will find the costs on their taxes. Assessments typically are under \$50. INFO.

- Oliver Moir replied that the culverts are proposed to be flushed. INFO.

7. Gary Coles asked if lands being developed for the proposed battery plant will affect the drainage in the area. INFO.

- Andrew Dowie stated there are no firm plans to change drainage but it would be undertaken under the Drainage Act if required under a separate report. INFO.
- 8. Garry Rossi asked if the utility is not a landowner how are they assessed. INFO.
 - Oliver Moir responded with an explanation of Section 26 increased costs due to the presence of the utility. INFO.
- 9. Garry Rossi asked how a utility can protect their infrastructure from these assessments in the future. He asked about coordination and interaction during construction. INFO.
 - Mark Hernandez suggested to put utilities under the drains to protect utilities. He answered yes, there would be coordination with utilities for construction. Additional, new infrastructure and utility work presently happening at Banwell that affect drainage will be captured in future reports. INFO.
- 10. Landowner John asked about the drain on the west side of properties on Corbi. Is it part of this project? INFO.
 - Mark Hernandez answered that it is a private drain and not maintained under a report. INFO.
- 11. Domenic Viselli asked about the history of the existing tile (Branch North). INFO.
 - Sam Paglia explained it was the developer's responsibility and it can't be removed or abandoned. It must be maintained. INFO.
 - Mark Hernandez added he was trying to be fair and equitable with special benefit costs to fix Branch North. INFO.

Errors and/or Omissions

These minutes were prepared by Wendy Belisle, who should be notified of any errors and/or omissions.

"SCHEDULE B"
SCHEDULE OF ALLOWANCES
GOUIN DRAIN
TOWN OF TECUMSEH & CITY OF WINDSOR

TOWN OF TECUMSEH

Roll No.	Con.	Description	Owner	Section 30 Damages	Section 29 Land	Total Allowances
570-42920		Block 'A'	Daniel J. & Karen L. Omahen	\$0.00	\$70.00	\$70.00
570-43000		Block 'A'	Mirko & Radinka Vranesevic	\$0.00	\$115.00	\$115.00
570-43005		Block 'A'	Scott R. Babister	\$0.00	\$60.00	\$60.00
570-45902	2	Pt. Lots 147&148 RP12R1064 Pt. 2	2034053 Ontario Limited	\$700.00	\$1,403.00	\$2,103.00
570-45930	2 & 3	W. Pt. Lot 147 12R6571 Pt. 1	1486044 Ontario Ltd	\$530.00	\$1,176.00	\$1,706.00
570-45950	2	Pt. Lot 146 RP12R4263 Pt. 2 RP12R5826 Pts. 1&2	1486044 Ontario Ltd	\$785.00	\$1,749.00	\$2,534.00
570-46201	2	Pt. Lot 144&145 RP12R18339 Pt. 1	507822 Ontario Inc. First Mirage Management	\$485.00	\$1,077.00	\$1,562.00
TOTAL ALLOWANCES (Town of Tecumseh)				\$2,500.00	\$5,650.00	\$8,150.00
OVERALL TOTAL ALLOWANCES (Town of Tecumseh & City of Windsor)				\$2,500.00	\$5,650.00	\$8,150.00

"SCHEDULE C-1"
SCHEDULE OF ASSESSMENT
GOUIN DRAIN
TOWN OF TECUMSEH & CITY OF WINDSOR

TOWN OF TECUMSEH

ONTARIO LANDS:

Description	Area Affected		Owner	Special Benefit	Benefit	Outlet	Total Assessment
	(Acres)	(Ha.)					
570-46900	7.06	2.86 *	Ministry of Transportation Ontario	\$0.00	\$46.00	\$425.00	\$471.00
Total on Ontario Lands.....				\$0.00	\$46.00	\$425.00	\$471.00

MUNICIPAL LANDS:

Description	Area Affected		Owner	Special Benefit	Benefit	Outlet	Total Assessment
	(Acres)	(Ha.)					
County Road No. 22	8.86	3.59	County of Essex	\$0.00	\$486.00	\$2,293.00	\$2,779.00
Block 'A' Lands	112.38	45.48	Town of Tecumseh	\$0.00	\$5,530.00	\$30,388.00	\$35,918.00
Block 'A' Roads	27.13	10.98	Town of Tecumseh	\$0.00	\$1,929.00	\$12,373.00	\$14,302.00
Total on Municipal Lands.....				\$0.00	\$7,945.00	\$45,054.00	\$52,999.00

PRIVATELY-OWNED - NON-AGRICULTURAL LANDS:

Roll No.	Con.	Description	Area Affected (Acres)	Area Affected (Ha.)	Owner	Special Benefit	Benefit	Outlet	Total Assessment
570-44000	2	Plan 1222 E Pt. LOT 14 RP 12R12697 Pt. 1	0.00	0.00	Ryan A. Labute	\$3,898.00	\$0.00	\$0.00	\$3,898.00
570-46700	2	Pt. Lot 147 RP 12R5669 Pt. 1 & 2	0.77	0.31	Steve Babic Enterprises Ltd.	\$0.00	\$8.00	\$40.00	\$48.00
Total on Privately-Owned - Non-Agricultural Lands.....						\$3,898.00	\$8.00	\$40.00	\$3,946.00

PRIVATELY-OWNED - AGRICULTURAL LANDS (GRANTABLE)

Roll No.	Con.	Description	Area Affected (Acres)	Area Affected (Ha.)	Owner	Special Benefit	Benefit	Outlet	Total Assessment
570-45902	2	Pt. Lots 147&148 RP12R1064 Pt. 2	32.79	13.27	2034053 Ontario Ltd.	\$3,121.00	\$994.00	\$2,814.00	\$6,929.00
570-45930	2 & 3	W. Pt. Lot 147 12R6571 Pt. 1	30.76	12.45	1486044 Ontario Ltd.	\$4,992.00	\$867.00	\$2,527.00	\$8,386.00
570-45950	2	Pt. Lot 146 RP12R4263 Pt. 2 RP12R5826 Pts. 1&2	40.53	16.40	1486044 Ontario Ltd.	\$6,863.00	\$1,224.00	\$3,043.00	\$11,130.00
570-46201	2	Pt. Lot 144&145 RP12R18339 Pt. 1	22.19	8.98	507822 Ontario Inc. First Mirage Management Inc.	\$2,848.00	\$622.00	\$1,607.00	\$5,077.00
Total on Privately-Owned - Agricultural Lands (Grantable).....						\$17,824.00	\$3,707.00	\$9,991.00	\$31,522.00

SECTION 26 & NON-AGRICULTURAL LANDS (NON-PRORATABLE)

Roll No.	Con.	Description	Owner	Special Benefit	Benefit	Outlet	Total Assessment
Shawnee Road			Town of Tecumseh	\$4,131.00	\$0.00	\$0.00	\$4,131.00
Total Section 26 & Non-Agricultural Lands (Non Pro-ratable).....				\$4,131.00	\$0.00	\$0.00	\$4,131.00
TOTAL ASSESSMENT (Town of Tecumseh)				\$25,853.00	\$11,706.00	\$55,510.00	\$93,069.00

	(Acres)	(Ha.)
Total Area		
Town of Tecumseh:	282.47	114.32

CITY OF WINDSOR

MUNICIPAL LANDS:

Description	Area Affected (Acres) (Ha.)		Owner	Special Benefit	Benefit	Outlet	Total Assessment
Anchor Drive	2.68	1.08	City of Windsor	\$0.00	\$599.00	\$705.00	\$1,304.00
Banwell Road	19.91	8.06	City of Windsor	\$351.00	\$1,331.00	\$6,628.00	\$8,310.00
E.C. Row Expressway	58.90	23.84	City of Windsor	\$0.00	\$7,705.00	\$15,354.00	\$23,059.00
E.C. Row Avenue East	6.00	2.43	City of Windsor	\$0.00	\$2,368.00	\$1,682.00	\$4,050.00
070-890-00600	1.82	0.74	City of Windsor	\$0.00	\$27.00	\$129.00	\$156.00
070-890-05500	7.65	3.10	Windsor Utilities Commission	\$0.00	\$84.00	\$405.00	\$489.00
070-950-20401	0.23	0.09	City of Windsor	\$0.00	\$4.00	\$15.00	\$19.00
090-040-00103	105.74	42.80	City of Windsor	\$75,453.00	\$3,471.00	\$9,117.00	\$88,041.00
090-040-03402	5.14	2.08	City of Windsor	\$0.00	\$113.00	\$606.00	\$719.00
090-040-03403	7.55	3.06	City of Windsor	\$8,416.00	\$423.00	\$652.00	\$9,491.00
090-040-03502	1.80	0.73	City of Windsor	\$0.00	\$79.00	\$425.00	\$504.00
090-040-04000	1.57	0.64	City of Windsor	\$0.00	\$26.00	\$136.00	\$162.00
090-040-05000	11.06	4.48	City of Windsor	\$0.00	\$121.00	\$572.00	\$693.00
Block 'E' Lands	4.60	1.86	City of Windsor	\$0.00	\$635.00	\$614.00	\$1,249.00
Block 'E' Roads	1.28	0.52	City of Windsor	\$0.00	\$135.00	\$286.00	\$421.00
Total on Municipal Lands.....				\$84,220.00	\$17,121.00	\$37,326.00	\$138,667.00

PRIVATELY-OWNED - NON-AGRICULTURAL LANDS:

Roll No.	Con.	Description	Area Affected (Acres) (Ha.)		Owner	Special Benefit	Benefit	Outlet	Total Assessment
070-650-01303	3	Pt. Lot 138&139 RP12R25708 Pts. 1-3, 6&12	2.90	1.17	Gary Barbesin	\$2,497.00	\$88.00	\$160.00	\$2,745.00
070-650-01351	3	Pt. Lot 138 RP 12R25708 Pts. 4, 5, 7 to 11			Jamieson Laboratories Ltd	\$2,500.00	\$0.00	\$0.00	\$2,500.00
Total on Privately-Owned - Non-Agricultural Lands.....						\$4,997.00	\$88.00	\$160.00	\$5,245.00

SECTION 26 & NON-AGRICULTURAL LANDS (NON-PRORATABLE)

Roll No.	Con.	Description	Owner	Special Benefit	Benefit	Outlet	Total Assessment
Public Utility			City of Windsor	\$255,279.00	\$0.00	\$0.00	\$255,279.00
Public Utility			Enbridge Gas Inc.	\$27,605.00	\$0.00	\$0.00	\$27,605.00
Public Utility			Bell Canada Inc.	\$27,605.00	\$0.00	\$0.00	\$27,605.00
Public Utility			Enwin Water	\$27,055.00	\$0.00	\$0.00	\$27,055.00
Public Utility			Enwin Powerlines	\$86,325.00	\$0.00	\$0.00	\$86,325.00
Total Section 26 & Non-Agricultural Lands (Non Pro-ratable).....				\$423,869.00	\$0.00	\$0.00	\$423,869.00
TOTAL ASSESSMENT (City of Windsor)				\$513,086.00	\$17,209.00	\$37,486.00	\$567,781.00

	(Acres)	(Ha.)
Total Area	-----	-----
City of Windsor:	238.83	96.68

	(Acres)	(Ha.)
Total Area	-----	-----
Town of Tecumseh & City of Windsor	521.30	211.00

TOTAL OVERALL ASSESSMENT (Town of Tecumseh & City of Windsor) **\$538,939.00** **\$28,915.00** **\$92,996.00** **\$660,850.00**

* DENOTES LANDS WITH REDUCED ASSESSEMENT FOR WOODLOT

"SCHEDULE C-2"
SCHEDULE OF ASSESSMENT
GOUIN DRAIN BRANCH NORTH
TOWN OF TECUMSEH

MUNICIPAL LANDS:

Description	Area Affected		Owner	Special Benefit	Benefit	Outlet	Total Assessment
	(Acres)	(Ha.)					
Gouin Street			Town of Tecumseh	\$14,450.00	\$0.00	\$0.00	\$14,450.00
Total on Municipal Lands.....				\$14,450.00	\$0.00	\$0.00	\$14,450.00

PRIVATELY-OWNED - NON-AGRICULTURAL LANDS:

Roll No.	Con.	Description	Area Affected		Owner	Special Benefit	Benefit	Outlet	Total Assessment
			(Acres)	(Ha.)					
570-43250	2	Plan 1222 Pt. Lot 11 R1216082 Pts 6, 30 & 60	0.15	0.06	Zoran & Milica Stojadinovic	\$0.00	\$0.00	\$888.00	\$888.00
570-43260	2	Plan 1222 Pt. Lot 11 R1216082 Pts 5, 29 & 59	0.15	0.06	Catherine M. & Ross A. Danby	\$0.00	\$0.00	\$826.00	\$826.00
570-43270	2	Plan 1222 Pt. Lot 11 R1216082 Pts 4, 28 & 58	0.13	0.05	David T. Gallant	\$0.00	\$0.00	\$596.00	\$596.00
570-43280	2	Plan 1222 Pt. Lot 11 R1216082 Pts 3, 27 & 57	0.13	0.05	Brian & Elisa Houston	\$0.00	\$2,050.00	\$529.00	\$2,579.00
570-43290	2	Plan 1222 Pt. Lot 11 R1216082 Pts 2, 26 & 56	0.13	0.05	John & Silvana Crispo	\$0.00	\$2,050.00	\$462.00	\$2,512.00
570-43295	2	Plan 1222 Pt. Lot 11 12R16082 Pts 1, 25 & 53 to 55	0.13	0.05	Troy & Lisa-Marie Meloche	\$0.00	\$2,050.00	\$400.00	\$2,450.00
570-43300	2	Plan 1222 Pt. Lots 10 & 11 12R13869 Part 1	0.74	0.30	Giuseppe Viselli	\$0.00	\$3,025.00	\$1,998.00	\$5,023.00
570-43400	2	Plan 1222 N Pt. Lot 10	0.21	0.09	Gilles A. & Lynda M. Lacombe	\$0.00	\$0.00	\$479.00	\$479.00
570-43500	2	Plan 1222 Pt. Lot 10	0.21	0.09	Scott R. Liebrock & Alexis R. Sovie	\$0.00	\$0.00	\$555.00	\$555.00
570-43600	2	Plan 1222 Pt. Lot 10	0.22	0.09	Dwain & Nancy Lariviere	\$0.00	\$0.00	\$635.00	\$635.00
570-43700	2	Plan 1222 S Pt. Lot 10	0.07	0.03	Andre Viselli	\$0.00	\$0.00	\$238.00	\$238.00
570-43800	2	Plan 1222 N Pt. Lot 13	0.46	0.19	Joanne L. Pierre	\$0.00	\$0.00	\$1,569.00	\$1,569.00
Total on Privately-Owned - Non-Agricultural Lands.....						\$0.00	\$9,175.00	\$9,175.00	\$18,350.00

NON-AGRICULTURAL LANDS (NON-PRORATABLE)

Roll No.	Con.	Description	Area Affected		Owner	Special Benefit	Benefit	Outlet	Total Assessment
			(Acres)	(Ha.)					
Gouin Street					Town of Tecumseh	\$35,250.00	\$0.00	\$0.00	\$35,250.00
Total Non-Agricultural Lands (Non Pro-ratable).....						\$35,250.00	\$0.00	\$0.00	\$35,250.00

TOTAL ASSESSMENT **\$49,700.00** **\$9,175.00** **\$9,175.00** **\$68,050.00**

Total Area	(Acres)	(Ha.)
	-----	-----
	2.74	1.11

"SCHEDULE C-3"
SCHEDULE OF ASSESSMENT
GOUIN DRAIN BRANCH SOUTH
TOWN OF TECUMSEH

MUNICIPAL LANDS

Description	Area Affected		Owner	Special Benefit	Benefit	Outlet	Total Assessment
	(Acres)	(Ha.)					
Block 'D' Lands	1.58	0.64	Town of Tecumseh	\$0.00	\$3,475.00	\$3,475.00	\$6,950.00
Municipal Lands.....				\$0.00	\$3,475.00	\$3,475.00	\$6,950.00
TOTAL ASSESSMENT				\$0.00	\$3,475.00	\$3,475.00	\$6,950.00
	(Acres)	(Ha.)					
Total Area:	1.58	0.64					

"SCHEDULE D-1"
DETAILS OF SPECIAL BENEFIT
GOUIN DRAIN
TOWN OF TECUMSEH & THE CITY OF WINDSOR

SPECIAL BENEFIT ASSESSMENT
(NON - AGRICULTURAL LANDS)

Roll No.	Owner	Item Description	Estimated Cost	Cost of Report	Special Benefit
Banwell Road	City of Windsor	<u>Station 2+162</u> - Supply and installation of stone erosion protection with filter fabric underlay (50%)	\$225.00	\$126.00	\$351.00
070-650-01303	Gary Barbesin	<u>Bridge No.6</u> - Station 1+109 (Future Replacement) (50%)	\$0.00	\$1,250.00	\$1,250.00
		<u>Station 1+104</u> - Supply and installation of stone erosion protection with filter fabric underlay (100%)	\$800.00	\$447.00	\$1,247.00
Total Special Benefit - Roll No. 070-650-01303			\$800.00	\$1,697.00	\$2,497.00
070-650-01351	Jamieson Laboratories Ltd	* <u>Bridge No.7</u> - Station 1+191 Secondary Access (Future Replacement) (100%)	\$0.00	\$2,500.00	\$2,500.00
090-040-00103	City of Windsor	<u>Bridge No.9</u> - Station 1+442 Bridge Removal (100%)	\$2,500.00	\$5,565.00	\$8,065.00
		<u>Bridge No.10</u> - Station 1+646 Bridge Removal (100%)	\$2,500.00	\$5,565.00	\$8,065.00
		<u>Station 1+376</u> - Supply and installation of stone erosion protection with filter fabric underlay (100%)	\$1,250.00	\$699.00	\$1,949.00
		<u>Station 1+549</u> - Supply and installation of stone erosion protection with filter fabric underlay (100%)	\$800.00	\$447.00	\$1,247.00
		<u>Station 1+751</u> - Supply and installation of stone erosion protection with filter fabric underlay (100%)	\$800.00	\$447.00	\$1,247.00
		Costs associated with trucking and disposal of drain spoils excavated from the drain between Station 1+191 and Station 2+116, including engineering cost portion of report modifications (100%)	\$35,200.00	\$19,680.00	\$54,880.00
Total Special Benefit - Roll No. 090-040-00103			\$43,050.00	\$32,403.00	\$75,453.00
090-040-03403	City of Windsor	<u>Bridge No.8</u> - Station 1+278 Bridge Removal (100%)	\$2,500.00	\$5,565.00	\$8,065.00
		<u>Station 2+162</u> - Supply and installation of stone erosion protection with filter fabric underlay (50%)	\$225.00	\$126.00	\$351.00
Total Special Benefit - Roll No. 090-040-03403			\$2,725.00	\$5,691.00	\$8,416.00
570-44000	Ryan A. Labute	* <u>Bridge No.19</u> - Station 3+167 Removal of 600 mm CSP, 12m in length (100%)	\$1,500.00	\$839.00	\$2,339.00
		Costs associated with trucking and disposal of contaminated material excavated from the drain (100%)	\$1,000.00	\$559.00	\$1,559.00
Total Special Benefit - Roll No. 570-44000			\$2,500.00	\$1,398.00	\$3,898.00
Total Special Benefit Assessment (Non - Agricultural Lands).....			\$49,300.00	\$43,815.00	\$93,115.00

SPECIAL BENEFIT ASSESSMENT
(AGRICULTURAL LANDS GRANTABLE)

Roll No.	Owner	Item Description	Estimated Cost	Cost of Report	Special Benefit
570-45902	2034053 Ontario Ltd.	<u>Bridge No.18</u> - Station 2+675 (Future Replacement) (50%)	\$0.00	\$1,250.00	\$1,250.00
		<u>Station 2+572</u> - Supply and installation of stone erosion protection with filter fabric underlay (50%)	\$1,200.00	\$665.00	\$1,865.00
		Total Special Benefit - Roll No. 570-45902	\$1,200.00	\$1,915.00	\$3,115.00
570-45930	1486044 Ontario Ltd.	<u>Station 2+452</u> - Supply and installation of stone erosion protection with filter fabric underlay (50%)	\$1,200.00	\$665.00	\$1,865.00
		<u>Station 2+572</u> - Supply and installation of stone erosion protection with filter fabric underlay (50%)	\$1,200.00	\$665.00	\$1,865.00
		<u>Bridge No. 17</u> - Station 2+567 (Future Replacement) (50%)	\$0.00	\$1,250.00	\$1,250.00
		Total Special Benefit - Roll No. 570-45930	\$2,400.00	\$2,580.00	\$4,980.00
570-45950	1486044 Ontario Ltd.	<u>Station 2+275</u> - Supply and installation of stone erosion protection with filter fabric underlay (50%)	\$800.00	\$443.00	\$1,243.00
		<u>Station 2+363</u> - Supply and installation of stone erosion protection with filter fabric underlay (100%)	\$1,600.00	\$886.00	\$2,486.00
		<u>Station 2+452</u> - Supply and installation of stone erosion protection with filter fabric underlay (50%)	\$1,200.00	\$665.00	\$1,865.00
		<u>Bridge No. 15</u> - Station 2+359 (Future Replacement) (50%)	\$0.00	\$1,250.00	\$1,250.00
		Total Special Benefit - Roll No. 570-45950	\$3,600.00	\$3,244.00	\$6,844.00
570-46201	507822 Ontario Inc. First Mirage Management Inc.	<u>Station 2+162</u> - Supply and installation of stone erosion protection with filter fabric underlay (50%)	\$225.00	\$125.00	\$350.00
		<u>Station 2+275</u> - Supply and installation of stone erosion protection with filter fabric underlay (50%)	\$800.00	\$443.00	\$1,243.00
		<u>Bridge No.14</u> - Station 2+208 (Future Replacement) (50%)	\$0.00	\$1,250.00	\$1,250.00
		Total Special Benefit - Roll No. 570-46201	\$1,025.00	\$1,818.00	\$2,843.00
Total Special Benefit Assessment (Agricultural Lands Grantable).....			\$8,225.00	\$9,557.00	\$17,782.00

(SECTION 26 & NON - AGRICULTURAL LANDS NON-PRORATABLE)

Roll No.	Owner	Item Description	Estimated Cost	Cost of Report	Special Benefit
Shawnee Road	Town of Tecumseh	<u>Bridge No.20</u> - Station 2+201 (Future Replacement + Bridge Cleaning) (100%)	\$500.00	\$3,631.00	\$4,131.00
E.C. Row Expressway	City of Windsor	<u>Station 0+098</u> - Supply and installation of stone erosion protection with filter fabric underlay (100%)	\$1,250.00	\$323.00	\$1,573.00
E.C. Row Expressway	City of Windsor	Costs associated with the trucking and disposal of contaminated material excavated from the drain (100%)	\$171,450.00	\$44,300.00	\$215,750.00
E.C. Row Expressway	City of Windsor	<u>Bridge No.2</u> - Removal (100%)	\$2,500.00	\$646.00	\$3,146.00
E.C. Row Expressway	City of Windsor	<u>Bridge No.4</u> - Repair of drain bottom on downstream and upstream ends of bridge using stone erosion protection (100%)	\$20,600.00	\$5,323.00	\$25,923.00
Anchor Drive	City of Windsor	<u>Bridge No.5</u> - Station 1+020 (Future Replacement + Bridge Cleaning) (100%)	\$1,000.00	\$3,758.00	\$4,758.00
Banwell Road	City of Windsor	<u>Bridge No.13</u> - Station 2+116 (Future Replacement + Bridge Cleaning) (100%)	\$500.00	\$3,629.00	\$4,129.00
Total Special Benefit - City of Windsor			\$197,300.00	\$57,979.00	\$255,279.00
Public Utility	Enbridge Gas Inc.	<u>Bridge No.1</u> - Replacement (25%)	\$21,500.00	\$5,555.00	\$27,055.00
		Cost associated with daylighting gas distribution and transmission mains over Bridge No. 1 (50%)	\$0.00	\$550.00	\$550.00
Total Special Benefit - Enbridge Gas Inc.			\$21,500.00	\$6,105.00	\$27,605.00
Public Utility	Bell Canada Inc.	<u>Bridge No.1</u> - Replacement (25%)	\$21,500.00	\$5,555.00	\$27,055.00
		Cost associated with daylighting gas distribution and transmission mains over Bridge No.1 (50%)	\$0.00	\$550.00	\$550.00
Total Special Benefit - Bell Canada Inc.			\$21,500.00	\$6,105.00	\$27,605.00
Public Utility	Enwin Water	<u>Bridge No.1</u> - Replacement (25%)	\$21,500.00	\$5,555.00	\$27,055.00
Public Utility	Enwin Powerlines	<u>Bridge No.1</u> - Replacement (25%)	\$21,500.00	\$5,555.00	\$27,055.00
		<u>Bridge No.3</u> - Replacement (100%)	\$47,100.00	\$12,170.00	\$59,270.00
Total Special Benefit - Enwin Powerlines			\$68,600.00	\$17,725.00	\$86,325.00
Total Special Benefit Assessment (Section 26 & Non-Agricultural Lands Non Pro-Ratable)			\$330,900.00	\$97,100.00	\$428,000.00

OVERALL TOTAL SPECIAL BENEFIT ASSESSMENT \$538,641.00

* DENOTES SECONDARY ACCESS CULVERT

"SCHEDULE D-2"
DETAILS OF SPECIAL BENEFIT
GOUIN DRAIN BRANCH NORTH
TOWN OF TECUMSEH

SPECIAL BENEFIT ASSESSMENT
(NON - AGRICULTURAL LANDS)

Roll No.	Owner	Item Description	Estimated Cost	Cost of Report	Special Benefit
Gouin Street	Town of Tecumseh	Increased cost of work completed within residential lands, including pipe installation, temporary construction fencing, and property restoration (100%)	\$12,150.00	\$2,300.00	\$14,450.00
Total Special Benefit Assessment (Non - Agricultural Lands).....			\$12,150.00	\$2,300.00	\$14,450.00

SPECIAL BENEFIT ASSESSMENT
(NON - AGRICULTURAL LANDS NON-PRORATABLE)

Roll No.	Owner	Item Description	Estimated Cost	Cost of Report	Special Benefit
Gouin Street	Town of Tecumseh	Non-proratable assessments include the cost of enclosed drain repair with non-shrink concrete grout, and the cost of the CCTV inspection (less flushing costs) (100%)	\$29,700.00	\$5,550.00	\$35,250.00
Total Special Benefit Assessment (Non - Agricultural Lands Non Pro-Rateable)			\$29,700.00	\$5,550.00	\$35,250.00
OVERALL TOTAL SPECIAL BENEFIT ASSESSMENT					\$49,700.00

"SCHEDULE E-1"
SCHEDULE OF ASSESSMENT FOR FUTURE MAINTENANCE
GOUIN DRAIN (STA 2+162 TO STA 3+286) WITHIN THE TOWN OF TECUMSEH

ONTARIO LANDS:

Description	Area Affected		Owner	Special Benefit	Benefit	Outlet	Total Assessment
	(Acres)	(Ha.)					
570-46900	7.06	2.86 *	Ministry of Transportation Ontario	\$0.00	\$9.00	\$37.00	\$46.00
Total on Ontario Lands.....				\$0.00	\$9.00	\$37.00	\$46.00

MUNICIPAL LANDS:

Description	Area Affected		Owner	Special Benefit	Benefit	Outlet	Total Assessment
	(Acres)	(Ha.)					
Block 'A' Lands	112.38	45.48	Town of Tecumseh	\$0.00	\$1,208.0	\$4,570.00	\$5,778.00
Block 'A' Roads	27.13	10.98	Town of Tecumseh	\$0.00	\$406.00	\$1,839.00	\$2,245.00
Total on Municipal Lands.....				\$0.00	\$1,614.00	\$6,409.00	\$8,023.00

PRIVATELY-OWNED - AGRICULTURAL LANDS (GRANTABLE)

Roll No.	Con.	Description	Area Affected		Owner	Special Benefit	Benefit	Outlet	Total Assessment
			(Acres)	(Ha.)					
570-45902	2	Pt. Lots 147&148 RP12R1064 Pt. 2	32.79	13.27	2034053 Ontario Ltd.	\$0.00	\$241.00	\$340.00	\$581.00
570-45930	2 & 3	W. Pt. Lot 147 12R6571 Pt. 1	24.76	10.02	1486044 Ontario Ltd.	\$0.00	\$196.00	\$228.00	\$424.00
570-45950	2	Pt. Lot 146 RP12R4263 Pt. 2 RP12R5826 Pts. 1&2	37.53	15.19	1486044 Ontario Ltd.	\$0.00	\$291.00	\$321.00	\$612.00
570-46201	2	Pt. Lot 144&145 RP12R18339 Pt. 1	22.19	8.98	507822 Ontario Inc. First Mirage Management Inc.	\$0.00	\$149.00	\$165.00	\$314.00
Total on Privately-Owned - Agricultural Lands (Grantable).....						\$0.00	\$877.00	\$1,054.00	\$1,931.00
TOTAL ASSESSMENT (Town of Tecumseh)						\$0.00	\$2,500.00	\$7,500.00	\$10,000.00

	(Acres)	(Ha.)
Total Area	-----	-----
Town of Tecumseh:	263.84	106.78

* DENOTES LANDS WITH REDUCED ASSESSEMENT FOR WOODLOT

"SCHEDULE E-2"
SCHEDULE OF ASSESSMENT FOR FUTURE MAINTENANCE
GOUIN DRAIN (STA 0+000 TO STA 2+162) WITHIN CITY OF WINDSOR

TOWN OF TECUMSEH

ONTARIO LANDS:

Description	Area Affected		Owner	Special Benefit	Benefit	Outlet	Total Assessment
	(Acres)	(Ha.)					
570-46900	7.06	2.86 *	Ministry of Transportation Ontario	\$0.00	\$4.00	\$29.00	\$33.00
Total on Ontario Lands.....				\$0.00	\$4.00	\$29.00	\$33.00

MUNICIPAL LANDS:

Description	Area Affected		Owner	Special Benefit	Benefit	Outlet	Total Assessment
	(Acres)	(Ha.)					
County Road No. 22	8.86	3.59	County of Essex	\$0.00	\$37.00	\$206.00	\$243.00
Block 'A' Lands	112.38	45.48	Town of Tecumseh	\$0.00	\$478.00	\$2,205.00	\$2,683.00
Block 'A' Roads	27.13	10.98	Town of Tecumseh	\$0.00	\$167.00	\$887.00	\$1,054.00
Total on Municipal Lands.....				\$0.00	\$682.00	\$3,298.00	\$3,980.00

PRIVATELY-OWNED - NON-AGRICULTURAL LANDS:

Roll No.	Con.	Description	Area Affected (Acres)	Area Affected (Ha.)	Owner	Special Benefit	Benefit	Outlet	Total Assessment
570-46700	2	Pt. Lot 147 RP 12R5669 Pt. 1 & 2	0.77	0.31	Steve Babic Enterprises Ltd.	\$0.00	\$1.00	\$4.00	\$5.00
Total on Privately-Owned - Non-Agricultural Lands.....						\$0.00	\$1.00	\$4.00	\$5.00

PRIVATELY-OWNED - AGRICULTURAL LANDS (GRANTABLE)

Roll No.	Con.	Description	Area Affected (Acres)	Area Affected (Ha.)	Owner	Special Benefit	Benefit	Outlet	Total Assessment
570-45902	2	Pt. Lots 147&148 RP12R1064 Pt. 2	32.79	13.27	2034053 Ontario Ltd.	\$0.00	\$86.00	\$214.00	\$300.00
570-45930	2 & 3	W. Pt. Lot 147 12R6571 Pt. 1	30.76	12.45	1486044 Ontario Ltd.	\$0.00	\$75.00	\$201.00	\$276.00
570-45950	2	Pt. Lot 146 RP12R4263 Pt. 2 RP12R5826 Pts. 1&2	40.53	16.40	1486044 Ontario Ltd.	\$0.00	\$106.00	\$265.00	\$371.00
570-46201	2	Pt. Lot 144&145 RP12R18339 Pt. 1	22.19	8.98	507822 Ontario Inc. First Mirage Management Inc.	\$0.00	\$54.00	\$145.00	\$199.00
Total on Privately-Owned - Agricultural Lands (Grantable).....						\$0.00	\$321.00	\$825.00	\$1,146.00

TOTAL ASSESSMENT (Town of Tecumseh) **\$0.00 \$1,008.00 \$4,156.00 \$5,164.00**

	(Acres)	(Ha.)
Total Area	-----	-----
Town of Tecumseh:	282.47	114.32

CITY OF WINDSOR

MUNICIPAL LANDS:

Description	Area Affected		Owner	Special	Benefit	Outlet	Total
	(Acres)	(Ha.)		Benefit			Assessment
Anchor Drive	2.68	1.08	City of Windsor	\$0.00	\$56.00	\$65.00	\$121.00
Banwell Road	19.91	8.06	City of Windsor	\$0.00	\$115.00	\$651.00	\$766.00
E.C. Row Expressway	58.90	23.84	City of Windsor	\$0.00	\$666.00	\$1,377.00	\$2,043.00
E.C. Row Avenue East	6.00	2.43	City of Windsor	\$0.00	\$205.00	\$196.00	\$401.00
070-890-00600	1.82	0.74	City of Windsor	\$0.00	\$2.00	\$16.00	\$18.00
070-890-05500	7.65	3.10	Windsor Utilities Commission	\$0.00	\$7.00	\$38.00	\$45.00
070-950-20401	0.23	0.09	City of Windsor	\$0.00	\$0.00	\$1.00	\$1.00
090-040-00103	105.74	42.80	City of Windsor	\$0.00	\$300.00	\$721.00	\$1,021.00
090-040-03402	5.14	2.08	City of Windsor	\$0.00	\$10.00	\$48.00	\$58.00
090-040-03403	7.55	3.06	City of Windsor	\$0.00	\$37.00	\$52.00	\$89.00
090-040-03502	1.80	0.73	City of Windsor	\$0.00	\$7.00	\$34.00	\$41.00
090-040-04000	1.57	0.64	City of Windsor	\$0.00	\$2.00	\$11.00	\$13.00
090-040-05000	11.06	4.48	City of Windsor	\$0.00	\$10.00	\$46.00	\$56.00
Block 'E' Lands	4.60	1.86	City of Windsor	\$0.00	\$55.00	\$50.00	\$105.00
Block 'E' Roads	1.28	0.52	City of Windsor	\$0.00	\$12.00	\$23.00	\$35.00
Total on Municipal Lands.....				\$0.00	\$1,484.00	\$3,329.00	\$4,813.00

PRIVATELY-OWNED - NON-AGRICULTURAL LANDS:

Roll No.	Con.	Description	Area Affected		Owner	Special	Benefit	Outlet	Total
			(Acres)	(Ha.)		Benefit			Assessment
070-650-01303	3	Pt. Lot 138&139 RP12R25708 Pts. 1-3, 6&12	2.90	1.17	Gary Barbesin	\$0.00	\$8.00	\$15.00	\$23.00
Total on Privately-Owned - Non-Agricultural Lands.....						\$0.00	\$8.00	\$15.00	\$23.00

TOTAL ASSESSMENT (City of Windsor) \$0.00 \$1,492.00 \$3,344.00 \$4,836.00

Total Area	(Acres)	(Ha.)
City of Windsor:	238.83	96.68

Total Area	(Acres)	(Ha.)
Town of Tecumseh & City of Windsor	521.30	211.00

TOTAL OVERALL ASSESSMENT (Town of Tecumseh & City of Windsor) \$0.00 \$2,500.00 \$7,500.00 \$10,000.00

* DENOTES LANDS WITH REDUCED ASSESSEMENT FOR WOODLOT

"SCHEDULE E-3"
SCHEDULE OF ASSESSMENT FOR FUTURE MAINTENANCE
GOUIN DRAIN (BRIDGES 14, 15, 16, 17 & 18) WITHIN TOWN OF TECUMSEH

ONTARIO LANDS:

Description	Area Affected		Owner	Special Benefit	Benefit	Outlet	Total Assessment
	(Acres)	(Ha.)					
570-46900	7.06	2.86 *	Ministry of Transportation Ontario	\$0.00	\$0.00	\$74.00	\$74.00
Total on Ontario Lands.....				\$0.00	\$0.00	\$74.00	\$74.00

MUNICIPAL LANDS:

Description	Area Affected		Owner	Special Benefit	Benefit	Outlet	Total Assessment
	(Acres)	(Ha.)					
Block 'A' Lands	112.38	45.48	Town of Tecumseh	\$0.00	\$0.00	\$5,672.00	\$5,672.00
Block 'A' Roads	27.13	10.98	Town of Tecumseh	\$0.00	\$0.00	\$2,282.00	\$2,282.00
Total on Municipal Lands.....				\$0.00	\$0.00	\$7,954.00	\$7,954.00

PRIVATELY-OWNED - AGRICULTURAL LANDS (GRANTABLE)

Roll No.	Con.	Description	Area Affected		Owner	Special Benefit	Benefit	Outlet	Total Assessment
			(Acres)	(Ha.)					
570-45902	2	Pt. Lots 147&148 RP12R1064 Pt. 2	32.79	13.27	2034053 Ontario Ltd.	\$0.00	\$0.00	\$552.00	\$552.00
570-45930	2 & 3	W. Pt. Lot 147 12R6571 Pt. 1	24.76	10.02	1486044 Ontario Ltd.	\$0.00	\$0.00	\$416.00	\$416.00
570-45950	2	Pt. Lot 146 RP12R4263 Pt. 2 RP12R5826 Pts. 1&2	37.53	15.19	1486044 Ontario Ltd.	\$0.00	\$0.00	\$631.00	\$631.00
570-46201	2	Pt. Lot 144&145 RP12R18339 Pt. 1	22.19	8.98	507822 Ontario Inc. First Mirage Management Inc.	\$0.00	\$0.00	\$373.00	\$373.00
Total on Privately-Owned - Agricultural Lands (Grantable).....						\$0.00	\$0.00	\$1,972.00	\$1,972.00

TOTAL ASSESSMENT (Town of Tecumseh) \$0.00 \$0.00 \$10,000.00 \$10,000.00

	(Acres)	(Ha.)
Total Area		
Town of Tecumseh:	263.84	106.78

* DENOTES LANDS WITH REDUCED ASSESSEMENT FOR WOODLOT

"SCHEDULE E-4"
SCHEDULE OF ASSESSMENT FOR FUTURE MAINTENANCE
GOUIN DRAIN (BRIDGE 6) WITHIN CITY OF WINDSOR

TOWN OF TECUMSEH

ONTARIO LANDS:

Description	Area Affected		Owner	Special Benefit	Benefit	Outlet	Total Assessment
	(Acres)	(Ha.)					
570-46900	7.06	2.86 *	Ministry of Transportation Ontario	\$0.00	\$0.00	\$46.00	\$46.00
Total on Ontario Lands.....				\$0.00	\$0.00	\$46.00	\$46.00

MUNICIPAL LANDS:

Description	Area Affected		Owner	Special Benefit	Benefit	Outlet	Total Assessment
	(Acres)	(Ha.)					
Block 'A' Lands	112.38	45.48	Town of Tecumseh	\$0.00	\$0.00	\$3,546.00	\$3,546.00
Block 'A' Roads	27.13	10.98	Town of Tecumseh	\$0.00	\$0.00	\$1,427.00	\$1,427.00
Total on Municipal Lands.....				\$0.00	\$0.00	\$4,973.00	\$4,973.00

PRIVATELY-OWNED - AGRICULTURAL LANDS (GRANTABLE)

Roll No.	Con.	Description	Area Affected		Owner	Special Benefit	Benefit	Outlet	Total Assessment
			(Acres)	(Ha.)					
570-45902	2	Pt. Lots 147&148 RP12R1064 Pt. 2	32.79	13.27	2034053 Ontario Ltd.	\$0.00	\$0.00	\$345.00	\$345.00
570-45930	2 & 3	W. Pt. Lot 147 12R6571 Pt. 1	24.76	10.02	1486044 Ontario Ltd.	\$0.00	\$0.00	\$260.00	\$260.00
570-45950	2	Pt. Lot 146 RP12R4263 Pt. 2 RP12R5826 Pts. 1&2	37.53	15.19	1486044 Ontario Ltd.	\$0.00	\$0.00	\$395.00	\$395.00
570-46201	2	Pt. Lot 144&145 RP12R18339 Pt. 1	22.19	8.98	507822 Ontario Inc. First Mirage Management Inc.	\$0.00	\$0.00	\$233.00	\$233.00
Total on Privately-Owned - Agricultural Lands (Grantable).....						\$0.00	\$0.00	\$1,233.00	\$1,233.00

TOTAL ASSESSMENT (Town of Tecumseh) **\$0.00** **\$0.00** **\$6,252.00** **\$6,252.00**

	(Acres)	(Ha.)
Total Area	-----	-----
Town of Tecumseh:	263.84	106.78

CITY OF WINDSOR

MUNICIPAL LANDS:

Description	Area Affected		Owner	Special Benefit	Benefit	Outlet	Total Assessment
	(Acres)	(Ha.)					
Anchor Drive	2.68	1.08	City of Windsor	\$0.00	\$0.00	\$140.00	\$140.00
Banwell Road	19.91	8.06	City of Windsor	\$0.00	\$0.00	\$1,047.00	\$1,047.00
E.C. Row Avenue East	6.00	2.43	City of Windsor	\$0.00	\$0.00	\$316.00	\$316.00
070-890-00600	1.82	0.74	City of Windsor	\$0.00	\$0.00	\$26.00	\$26.00
070-890-05500	7.65	3.10	Windsor Utilities Commission	\$0.00	\$0.00	\$81.00	\$81.00
090-040-00103	105.74	42.80	City of Windsor	\$0.00	\$0.00	\$1,668.00	\$1,668.00
090-040-03402	5.14	2.08	City of Windsor	\$0.00	\$0.00	\$108.00	\$108.00
090-040-03403	7.55	3.06	City of Windsor	\$0.00	\$0.00	\$119.00	\$119.00
090-040-03502	1.80	0.73	City of Windsor	\$0.00	\$0.00	\$76.00	\$76.00
090-040-04000	1.57	0.64	City of Windsor	\$0.00	\$0.00	\$25.00	\$25.00
090-040-05000	11.06	4.48	City of Windsor	\$0.00	\$0.00	\$116.00	\$116.00
Total on Municipal Lands.....				\$0.00	\$0.00	\$3,722.00	\$3,722.00

PRIVATELY-OWNED - NON-AGRICULTURAL LANDS:

Roll No.	Con.	Description	Area Affected		Owner	Special Benefit	Benefit	Outlet	Total Assessment
			(Acres)	(Ha.)					
070-650-01303	3	Pt. Lot 138&139 RP12R25708 Pts. 1-3, 6&12	2.00	0.81	Gary Barbesin	\$0.00	\$0.00	\$26.00	\$26.00
Total on Privately-Owned - Non-Agricultural Lands.....						\$0.00	\$0.00	\$26.00	\$26.00

TOTAL ASSESSMENT (City of Windsor) \$0.00 \$0.00 \$3,748.00 \$3,748.00

	(Acres)	(Ha.)
Total Area	-----	-----
City of Windsor:	172.92	70.01
Total Area	-----	-----
Town of Tecumseh & City of Windsor	436.76	176.79

TOTAL OVERALL ASSESSMENT (Town of Tecumseh & City of Windsor) \$0.00 \$0.00 \$10,000.00 \$10,000.00

* DENOTES LANDS WITH REDUCED ASSESSEMENT FOR WOODLOT

"SCHEDULE E-5"
SCHEDULE OF ASSESSMENT FOR FUTURE MAINTENANCE
GOUIN DRAIN BRANCH NORTH (STA. 0+000A TO STA. 0+064A)
TOWN OF TECUMSEH

MUNICIPAL LANDS:

Description	Area Affected		Owner	Special Benefit	Benefit	Outlet	Total Assessment
	(Acres)	(Ha.)					
Block 'B' Roads	12.75	5.16	Town of Tecumseh	\$0.00	\$0.00	\$2,851.00	\$2,851.00
Block 'B' Lands	53.27	21.56	Town of Tecumseh	\$0.00	\$0.00	\$7,149.00	\$7,149.00
Total on Municipal Lands.....				\$0.00	\$0.00	\$10,000.00	\$10,000.00
TOTAL ASSESSMENT				\$0.00	\$0.00	\$10,000.00	\$10,000.00
	(Acres)	(Ha.)					
Total Area:	66.02	26.72					

"SCHEDULE E-6"
SCHEDULE OF ASSESSMENT FOR FUTURE MAINTENANCE
GOUIN DRAIN BRANCH NORTH (STA 0+064A TO STA 0+198A)
TOWN OF TECUMSEH

PRIVATELY-OWNED - NON-AGRICULTURAL LANDS:

Roll No.	Con.	Description			Owner	Special Benefit	Benefit	Outlet	Total Assessment
570-43250	2	Plan 1222 Pt. Lot 11 R1216082 Pts 6, 30 & 60	0.15	0.06	Zoran & Milica Stojadinovic	\$0.00	\$356.00	\$242.00	\$598.00
570-43260	2	Plan 1222 Pt. Lot 11 R1216082 Pts 5, 29 & 59	0.15	0.06	Catherine M. & Ross A. Danby	\$0.00	\$747.00	\$225.00	\$972.00
570-43270	2	Plan 1222 Pt. Lot 11 R1216082 Pts 4, 28 & 58	0.13	0.05	David T. Gallant	\$0.00	\$682.00	\$162.00	\$844.00
570-43280	2	Plan 1222 Pt. Lot 11 R1216082 Pts 3, 27 & 57	0.13	0.05	Brian & Elisa Houston	\$0.00	\$682.00	\$144.00	\$826.00
570-43290	2	Plan 1222 Pt. Lot 11 R1216082 Pts 2, 26 & 56	0.13	0.05	John & Silvana Crispo	\$0.00	\$682.00	\$126.00	\$808.00
570-43295	2	Plan 1222 Pt. Lot 11 12R16082 Pts 1, 25 & 53 to 55	0.13	0.05	Troy & Lisa-Marie Meloche	\$0.00	\$682.00	\$109.00	\$791.00
570-43300	2	Plan 1222 Pt. Lots 10 & 11 12R13869 Part 1	0.74	0.30	Giuseppe Viselli	\$0.00	\$2,955.00	\$544.00	\$3,499.00
570-43400	2	Plan 1222 N Pt. Lot 10	0.21	0.09	Gilles A. & Lynda M. Lacombe	\$0.00	\$0.00	\$131.00	\$131.00
570-43500	2	Plan 1222 Pt. Lot 10	0.21	0.09	Scott R. Liebrock & Alexis R. Sovie	\$0.00	\$0.00	\$151.00	\$151.00
570-43600	2	Plan 1222 Pt. Lot 10	0.22	0.09	Dwain & Nancy Lariviere	\$0.00	\$0.00	\$173.00	\$173.00
570-43700	2	Plan 1222 S Pt. Lot 10	0.07	0.03	Andre Viselli	\$0.00	\$0.00	\$65.00	\$65.00
570-43800	2	Plan 1222 N Pt. Lot 13	0.46	0.19	Joanne L. Pierre	\$0.00	\$714.00	\$428.00	\$1,142.00
Total on Privately-Owned - Non-Agricultural Lands.....						\$0.00	\$7,500.00	\$2,500.00	\$10,000.00
TOTAL ASSESSMENT						\$0.00	\$7,500.00	\$2,500.00	\$10,000.00

Total Area	(Acres)	(Ha.)
	-----	-----
	2.74	1.11

"SCHEDULE E-7"
SCHEDULE OF ASSESSMENT FOR FUTURE MAINTENANCE
GOUIN DRAIN BRANCH SOUTH
TOWN OF TECUMSEH

MUNICIPAL LANDS:

Description	Area Affected		Owner	Special Benefit	Benefit	Outlet	Total Assessment
	(Acres)	(Ha.)					
Block 'D' Lands	1.58	0.64	Town of Tecumseh	\$0.00	\$0.00	\$10,000.00	\$10,000.00
Total on Municipal Lands.....				\$0.00	\$0.00	\$10,000.00	\$10,000.00
TOTAL ASSESSMENT				\$0.00	\$0.00	\$10,000.00	\$10,000.00
	(Acres)	(Ha.)					
Total Area:	1.58	0.64					

“SCHEDULE F”
DRAINAGE REPORT FOR THE
GOUIN DRAIN & BRANCHES
TOWN OF TECUMSEH & CITY OF WINDSOR

SPECIAL PROVISIONS - GENERAL

1.0 GENERAL SPECIFICATIONS

The General Specifications attached hereto is part of “Schedule F.” It also forms part of this specification and is to be read with it, but where there is a difference between the requirements of the General Specifications and those of the Special Provisions which follow, the Special Provisions will take precedence.

2.0 DESCRIPTION OF WORK

The work to be carried out under this Contract includes, but is not limited to, the supply of all **labour, equipment, and materials to complete** the following items:

Gouin Drain

Open Drain Work

- Brushing of the drain including the disposal by burning on-site or removal off-site with trimming and/or removal of existing trees as required to accommodate the drainage works, as follows:
 - Light brushing between Stations 0+000 and 0+400, Stations 0+520 and 0+670, and Stations 1+032 and 2+116. Work includes temporary removal of approximately 210 metres of chain-link fence to access the drain, and restoration to existing conditions.
 - Medium brushing between Stations 2+116 and 2+758 (completed August 2020).
This item has been completed by the Town. It is not to be included when tendering the work for construction.
- Excavation, levelling, and trucking of excavated materials works, as follows:
 - Drain deepening, as follows:
 - Station 0+172 to Station 1+010, totalling approximately 838 lineal metres of drain and approximately 1,600 m³ of material.
 - Excavation of drain bottom only, as follows:
 - Station 1+010 to Station 2+758, totalling approximately 1,748 lineal metres of drain and approximately 1,390 m³ of material.
 - Station 3+128 to Station 3+208, totalling approximately 80 lineal metres of drain and approximately 25 m³ of material.
 - Trucking and disposal of excavated materials off-site, as follows:

- Stations 1+109 to Station 2+116, totalling approximately 880 m³ of material.
 - Stations 3+128 to Station 3+208, totalling approximately 25 m³ of material.
 - Levelling of excavated materials, as follows:
 - Station 1+010 to Station 1+109, totalling approximately 99 lineal metres of drain and approximately 10 m³ of material.
 - Station 2+116 to Station 2+758, totalling approximately 642 lineal metres of drain and approximately 500 m³ of material.
- Seeding of grass buffer strips, as follows:
 - Seeding of 1.0 m wide grass buffer strip beyond the top of bank on the south side of the drain from Station 1+032 to Station 2+107 (approximately 1,080 m²).
 - Seeding of 1.0 m wide grass buffer strip beyond the top of bank on the north and south side of the drain from Station 2+122 to Station 2+680 (approximately 1,120 m²).
 - Seeding of 1.0 m wide grass buffer strip beyond the top of bank on the west side of the drain from Station 2+680 to Station 2+758 (approximately 80 m²).
 - Seeding of 1.0 m wide grass buffer strip beyond the top of bank on the north and south side of the drain from Station 3+128 to Station 3+208 (approximately 160 m²).
- Private access bridge cleaning works, as follows:
 - Bridges No. 6, 7, 14, 15,16, 17, 18
- Removal of access bridges, as follows:
 - Bridge No. 8 – Station 1+278 – City of Windsor (Roll No. 090-040-00103) – The work is to include removal and disposal of existing 9.7 m long, 2240 mm x 1630 mm corrugated steel pipe arch as well as the existing bagged concrete headwalls and gravel driveway. Complete with grading and seeding of the drain banks, site clean-up and restoration within the working area.
 - Bridge No. 9 – Station 1+442 – City of Windsor (Roll No. 090-040-00103) – The work is to include removal and disposal of existing 8.2 m long, 2240 mm x 1630 mm corrugated steel pipe arch as well as the bagged concrete headwalls and gravel driveway. Complete with grading and seeding of the drain banks, site clean-up and restoration within the working area.
 - Bridge No. 10 – Station 1+646 – City of Windsor (Roll No. 090-040-00103) – The work is to include removal and disposal of existing 7.8 m long, 2240 mm x 1630 mm corrugated steel pipe arch as well as the existing concrete headwalls and gravel driveway. Complete with grading and seeding of the drain banks, site clean-up and restoration within the working area.
 - Bridge No. 19 – Station 3+167 – Ryan A. LaBute (Roll No. 570-44000) – The work is to include removal and disposal of existing 12 m long, 600 mm diameter corrugated steel pipe as well as the existing with rip rap and gravel

driveway. Complete with grading and seeding of the drain banks, site clean-up and restoration within the working area.

- Stone erosion protection (SEP) works, as follows:
 - Station 1+104 – Supply and install 10 m² (300 mm thick) of stone erosion protection (SEP) including new filter fabric underlay at the location of surface inlet swale on south side.
 - Station 1+376 – Supply and install 15 m² (300 mm thick) of stone erosion protection (SEP) including new filter fabric underlay at the location of surface inlet swale on south side.
 - Station 1+549 – Supply and install 10 m² (300 mm thick) of stone erosion protection (SEP) including new filter fabric underlay at the location of surface inlet swale on south side.
 - Station 1+751 – Supply and install 10 m² (300 mm thick) of stone erosion protection (SEP) including new filter fabric underlay at the location of surface inlet swale on south side.
 - Station 2+162 – Supply and install 5 m² (300 mm thick) of stone erosion protection (SEP) including new filter fabric underlay at the location of surface inlet swale on south side.
 - Station 2+275 – Supply and install 20 m² (300 mm thick) of stone erosion protection (SEP) including new filter fabric underlay at the location of surface inlet swale on north and south side.
 - Station 2+363 – Supply and install 20 m² (300 mm thick) of stone erosion protection (SEP) including new filter fabric underlay at the location of surface inlet swale on north and south side.
 - Station 2+452 – Supply and install 30 m² (300 mm thick) of stone erosion protection (SEP) including new filter fabric underlay at the location of surface inlet swale on north and south side.
 - Station 2+572 – Supply and install 30 m² (300 mm thick) of stone erosion protection (SEP) including new filter fabric underlay at the location of surface inlet swale on north and south side.
- Temporary Silt Control Measures During Construction
- Trucking of excavated materials works, as follows:
 - Trucking and landfilling of contaminated excavated materials off-site, as follows:
 - Station 0+162 to Station 0+250, totalling approximately 45 m³ of material.
 - Station 0+470 to Station 1+010, totalling approximately 1,005 m³ of material.
 - Trucking of excavated materials off-site to a site capable of receiving soils meeting the Table 3.1 RPI and/or 3.1 ICC ESWS that has a salt-parameter exemption, as follows:

- Station 0+250 to Station 0+470, totalling approximately 550 m³ of material.
- Stone erosion protection (SEP) works, as follows:
 - Station 0+098 – Supply and install 15 m² (300 mm thick) of stone erosion protection (SEP) including new filter fabric underlay at the location of washout on south drain bank.
- Private access bridge cleaning works, as follows:
 - Cleaning of Bridge No. 5 – Station 1+020 19 m long, 1520 mm diameter corrugated steel pipe (CSP) road culvert.
 - Cleaning of Bridge No. 13 – Station 2+116 15.6 m long, 2230 mm x 1700 mm corrugated steel pipe arch (CSPA) road culvert.
 - Cleaning of Bridge No. 20 – Station 3+214 12 m long, 760 mm diameter corrugated steel pipe (CSP) road culvert.
- Bridge works, as follows:
 - Bridge No. 1 – Station 0+200 (Enbridge Gas, Enwin Water & Bell Canada) – Removal and disposal of existing 28 m long twin 1370 mm x 1000 mm CSPA, existing end walls and backfill off-site that are not suitable for native backfill. Installation of a new 32 m long, 2500 mm x 1830 mm corrugated steel pipe arch (CSPA). Clear stone bedding material beneath pipe minimum 150 mm thickness, up to pipe springline (approximately 110 tonnes). Clean native or imported clean native backfill material from springline of pipe culvert to the underside of grassed driveway (approximately 300 m³). Topsoil (approximately 15 m³), fine grading and seeding (approximately 230 m²). Sloping stone end walls and lining of drain bottom with stone erosion protection to allow for excavation below proposed grade line at upstream and downstream ends of culvert (approximately 130 m²). Removal and restoration of fence to existing conditions. Cost includes installation of all necessary supports for existing utilities necessary during construction and third party inspection.
 - Bridge No. 3 – Station 0+825 (Enwin Powerlines) – Removal and disposal of existing 7 m long, twin 1520 mm x 1160 mm CSPA, existing end walls and backfill off-site that are not suitable for native backfill. Installation of a new 16 m long, 2500 mm x 1830 mm corrugated steel pipe arch (CSPA). Clear stone bedding material minimum 150 mm beneath pipe, up to pipe springline (approximately 75 tonnes). Granular 'B' backfill up to the underside of Granular 'A' driveway material (approximately 115 tonnes). Native material backfill beyond edges of driveway to construct the 0.5 m wide native buffer strips (approximately 30 m³). Granular 'A' (crushed limestone) compacted driveway surface, minimum 200 mm thickness (approximately 40 tonnes). Sloping stone end walls and lining of drain bottom with stone erosion protection to allow for excavation below proposed grade line at upstream and downstream ends of culvert (approximately 85 m²).

- Bridge repairs, as follows:
 - Bridge No. 4 – Station 0+958 (City of Windsor) – Lining of drain bottom and drain banks on downstream and upstream ends of bridge where drain bottom falls below design grade using stone erosion protection (300 mm thickness) (approximately 260 m²) to be embedded into drain bottom.
- Removal of access bridges, as follows:
 - Bridge No. 2 – Station 0+534 – Removal and disposal of existing 6 m long twin 1900 mm x 1050 mm CSPA, existing end walls and backfill off-site. Complete with grading and seeding of the drain banks, site clean-up and restoration within the working area.

Gouin Drain Branch North

Closed Drain Work

- Work required within property Municipal No. 1800 Corbi Lane includes:
 - Station 0+091A - Supply and installation of one (1) new 600 mm x 600 mm precast concrete catch basin (denoted CB1) complete with cast iron heavy-duty grate as manufactured by Coldstream Concrete (or approved equal) and a minimum 300 mm deep sump. The grates shall be equipped with fasteners to secure grates to catch basins as supplied by the manufacturer. Work to include connection of all new and existing pipes and grouting of all voids around pipes with non-shrink concrete grout.
 - Station 0+079A to Station 0+091A - Supply and install approximately 12 metres of 300 mm diameter solid corrugated high density polyethylene (HDPE), smooth wall, 320 kPa pipe (Boss 2000 or approved equal) with bell and spigot joining system. Join pipe with existing 300 mm diameter HDPE pipe with Fernco coupler (or approved equal). Granular 'B' bedding beneath pipe, minimum 150 mm thickness and backfill up to springline of pipe (approximately 10 tonnes). Clean native backfill material from Granular 'B' to underside of top soil (approximately 27 m³). Minimum 50 mm thick layer of top soil above native material, fine grade and seed. Work includes removal and disposal of existing 12 metre (approx.) 1050 mm diameter corrugated steel pipe (CSP). The Contractor shall supply and install temporary construction fencing along the designated working corridor.
 - Reinstatement of fence and restoration of all disturbed areas to existing conditions.
- Work required within property Municipal No. 1806 Corbi Lane includes:
 - Station 0+112.5A - Supply and installation of one (1) new 600 mm x 600 mm precast concrete catch basin (denoted CB2) complete with cast iron heavy-duty grate as manufactured by Coldstream Concrete (or approved equal) and a minimum 300 mm deep sump. The grates shall be equipped with fasteners to secure grates to catch basins as supplied by the manufacturer. Remove and dispose a portion of existing 1050 mm diameter corrugated steel pipe (CSP) to accommodate installation of CB2. Work includes connection of all new and existing pipes and grouting of all voids around pipes with non-shrink concrete

- grout.
- Station 0+091A to Station 0+112.5A - Supply and install approximately 21.5 metres of 300 mm diameter polyethylene (PE), smooth wall pipe. Work includes slipping new 300 mm diameter PE pipe into existing 1050 mm diameter corrugated steel pipe (CSP). The Contractor shall supply and install temporary construction fencing along the designated working corridor.
 - Reinstatement of fence and restoration of all disturbed areas to existing conditions.
 - Work required within property Municipal No. 1812 Corbi Lane includes:
 - Station 0+133A – Remove and dispose of existing catch basin maintenance hole. Supply and installation of one (1) new 600 mm x 600 mm precast concrete catch basin (denoted CB3) complete with cast iron heavy-duty grate as manufactured by Coldstream Concrete (or approved equal) and a minimum 300 mm deep sump. The grates shall be equipped with fasteners to secure grates to catch basins as supplied by the manufacturer. Remove and dispose a portion of existing 1050 mm diameter corrugated steel pipe (CSP) to accommodate installation of CB3. Work includes connection of all new and existing pipes and grouting of all voids around pipes with non-shrink concrete grout.
 - Station 0+112.5A to Station 0+133A - Supply and install approximately 20.5 metres of 300 mm diameter solid corrugated high density polyethylene (HDPE), smooth wall, 320 kPa pipe (Boss 2000 or approved equal) with bell and spigot joining system. Work includes slipping new 300 mm diameter HDPE pipe into existing 1050 mm diameter corrugated steel pipe (CSP). The Contractor shall supply and install temporary construction fencing along the designated working corridor.
 - Reinstatement of fence and restoration of all disturbed areas restored to existing conditions.
 - Injection of non-shrink concrete grout to fill voids between the existing 1050 mm diameter corrugated steel pipe (CSP) and new 300 mm diameter high density polyethylene (HDPE) pipe between Station 0+091A and Station 0+133A (approximately 88 tonnes), ensuring the HDPE pipe does not shift within the CSP.

3.0 ACCESS TO THE WORK

Access to the drain from Station 0+000 to Station 0+942 shall be from E.C. Row Expressway near Bridge No. 3 at Station 0+825. Access to the drain from Station 0+982 to Station 1+104 shall be from Anchor Drive. Access to the drain from Station 1+191 to Station 2+116 shall be from E.C. Row Avenue East. Access to the drain from Station 2+116 to Station 2+758 shall be from Banwell Road using the access bridge located approximately 270 metres north of the Gouin Drain. Access to the work from Station 3+128 to Station 3+167 shall be from Shawnee Road.

Access to the work specified on Gouin Drain Branch North from Station 0+064A to Station 0+133A shall be from Gouin Street, from property Roll No. 570-43295 and Roll No. 570-43300.

All road areas, grass lawn areas and fence lines disturbed shall be restored to original conditions at the Contractor's expense. The Contractor shall make his/her own arrangements for any additional access for his/her convenience.

4.0 WORKING AREA

The Contractor shall restrict his equipment to the working corridors as specified in this Section. Any damage resulting from non-compliance with this Section shall be borne by the Contractor. The working corridor shall be measured from the top of the drain bank and shall be as follows:

FROM STA.	TO STA.	PRIMARY (See Note 1)	SECONDARY (See Note 2)
0+000	0+920	9 m wide on south side of drain	-
0+920	1+032	9 m wide on west side of drain	-
1+032	2+116	9 m wide on south side of drain	-
2+116	2+680	9 m wide on south side of drain*	6.0 m wide on north side of drain
2+680	2+758	9 m wide on west side of drain*	-
2+758	2+816	6 m centered over the drain	-
2+816	3+064	6 m centered over the drain (See Note 3)	-
3+064	3+128	2.2 m wide south of the drain and 2.8 m wide north of the drain (See Note 3)	-
3+128	3+207	6 m wide on south side of drain	-
3+207	3+286	6 m wide south of the drain and 3 m wide north of the drain	-
0+000A	0+080A	6 m centered over the drain	-
0+080A	0+198A	6 m centered over the drain	-
0+000B	0+071B	6 m centered over the drain	-

Note 1: *Primary working corridor* indicates the access corridor along the side of the drain where excavation and levelling is recommended (unless noted otherwise below and/or in the Specifications, as well as all purposes listed for Secondary Working

Corridors).

Note 2: *Secondary working corridor* indicates the access corridor alongside the drain where construction equipment may travel for the purpose of trucking, drain bank repairs, tile inlet repairs, surface water inlet repairs, grass buffer strips and other miscellaneous works. **No disposal of fill or levelling of materials shall be permitted within a secondary working corridor. As further specified, use of this secondary working corridor may be further restricted due to site condition. Read all Specifications, Drawings and/or notes before completing works.**

Note 3: The working corridor is adopting existing municipal easements.

***Note:** *In the event that a landowner owns the property on both sides of the drain, the landowner can choose which side of the drain to place the spoil. The landowner should advise the Drainage Superintendent of their preference of spoil placement before improvements to the drain are made so that the Drainage Superintendent can notify the Contractor in advance.*

SPECIAL PROVISIONS – OPEN DRAIN

5.0 BRUSHING

Brushing shall be carried out on the entire drain within the above identified sections of the drain where required and as specified herein. All brush and trees located within the drain side slopes shall be cut parallel to the side slopes, as close to the ground as practicable. Tree branches that overhang the drain shall be trimmed. Small branches and limbs are to be disposed of by the Contractor along with the other brush. Tree stumps, where removed to facilitate the drain excavation and reshaping of the drain banks, may be burned by the Contractor where permitted; otherwise, they shall be disposed of, off the site. The Contractor shall make every effort to preserve mature trees which are beyond the drain side slopes, and the working corridors. If requested to do so by the Drainage Superintendent, the Contractor shall preserve certain mature trees within the designated working corridors (see Section 4.0).

Except as specified herein, all brush and trees shall be stockpiled adjacent to the drain within the working corridors. Stockpiles shall not be less than 100 m apart and shall be a minimum of 2.0 m from the edge of the drain bank. All brush, timber, logs, stumps, large stones or other obstructions and deleterious materials that interfere with the construction of the drain, as encountered along the course of the drain are to be removed from the drain by the Contractor. Large stones and other similar material shall be disposed of by the Contractor off the site.

Following completion of the work, the Contractor is to trim up any broken or damaged limbs on trees which remain standing, disposing of the branches cut off along with other brush and leaving the trees in a neat and tidy condition. Brush and trees removed from the working area are to be put into piles by the Contractor, in locations where they can be safely burned, and to be burned by the Contractor after obtaining the necessary permits, as required. If, in the opinion of the Drainage Superintendent, any of the piles are too wet or green to be burned, he shall so advise the Contractor to haul away the unburned materials to an approved dump site. Prior to, and during the course of burning operations, the Contractor shall comply with the current guidelines prepared by the Air Quality Branch of the Ontario Ministry of Environment and shall ensure that the Environmental Protection Act is not violated. Since the trees and brush that are cut off flush with the earth surface may sprout new growth later, it is strongly recommended that the Municipality make arrangements for spraying this new growth at the appropriate time so as to kill the

trees and brush.

As part of this work, the Contractor shall remove any loose timber, logs, stumps, large stones or other debris from the drain bottom and from the side slopes. **Timber, logs, stumps, large stones or other debris shall be disposed of off-site.**

6.0 EXCAVATION AND LEVELLING OF EXCAVATED MATERIALS

6.1 Excavation of Existing Drain Channel

In all cases, the Contractor shall use the benchmarks to establish the proposed grade. However, for convenience, the drawings provide the approximate depth from the surface of the ground and from the existing drain bottom to the proposed grades.

THE CONTRACTOR SHALL NOT EXCAVATE DEEPER THAN THE GRADELINES SHOWN ON THE DRAWINGS. Should over-excavation of the drain bank occur, the Contractor will **not** be permitted to repair with native material packed into place by the excavator and reshaped. Should over-excavation occur, the Contractor will be required to have a bank repair detail engineered by a Professional Engineer (hired by the Contractor), to ensure long term stability of the bank is maintained. Such repairs shall be subject to approval by the Engineer and will be at no extra cost to the item.

All excavated material shall be handled as specified in either Section 6.2 or Section 17.0. Materials deposited on the farmlands shall be within the working corridors, at least 1.0 m from the top of the drain bank, or as specified on the drawings. Upon allowing drying of excavated materials (if necessary) and as approved by the Drainage Superintendent, the Contractor shall level excavated materials in accordance with Section 6.2. Excavated material shall not be placed on dykes, in ditches, tiles or depressions intended to conduct water into the drain.

Seeding of the disturbed drain banks shall be completed immediately following drain construction and as specified in Section 8.0.

All excavation work shall be done in such a manner as to not harm any vegetation or trees, not identified in this report or by the Drainage Superintendent for clearing. Any damages to trees or vegetation caused by the Contractors work shall be rectified to the satisfaction of the Drainage Superintendent.

The Contractor shall exercise caution around existing tile inlets and shall confirm with the property owners that all tiles have been located and tile ends repaired as specified.

6.2 Levelling of Excavated Materials

Excavation of the drain bottom shall be completed as specified in Section 6.1, above

and also as specified below and as shown on the drawings.

Excavated drain materials shall be spread to a depth not to exceed 300 mm, unless specified otherwise on the drawings. The material shall be sufficiently levelled to allow further working by agricultural implements. All stones and other debris removed from the drain, which may interfere with agricultural implements, shall be disposed of off-site. Excavated material shall not be placed on dykes, in ditches, tiles or depressions intended to conduct water into the drain.

6.3 Trucking of Excavated Materials

Trucking of excavated materials to an off-site disposal site is to be arranged by the Contractor as per Section 17.0 On-site and Excess Soil Management.

The Contractor shall be solely responsible for acquiring any and all permits and approvals required prior to hauling and disposal of materials off-site. The Contractor shall restore any such areas which are damaged by his operations, to original or better condition. The Contractor will be held liable for damages to roads, sodded areas and gardens, resulting from his non-compliance with these Specifications.

7.0 STONE EROSION PROTECTION (SEP)

The Contractor shall supply and install the required quantities of graded stone rip-rap erosion protection materials where specified. All stone to be used for erosion protection shall be 125 - 250 mm clear **quarried rock** or OPSS 1001 placed over a non-woven filter fabric Terrafix 270R or approved equivalent. **Concrete rip-rap will not be permitted.**

The minimum thickness requirement of the erosion stone layer is 300 mm with no portion of the filter fabric to be exposed.

8.0 HYDRAULIC SEEDING OF DRAIN BANKS

All existing grassed areas disturbed by construction shall be hydraulic mulch seeded as specified herein. The existing ground surface to be seeded shall be loosened to a depth of 25 mm and shall be rendered uniformly loose for that 25 mm depth. The surface shall be predominantly fine and free from weeds and other unwanted vegetation. All other loose surface litter shall be removed and disposed of.

Hydraulic mulch shall consist of finely ground cellulose pulp derived from recycled newsprint and shall be dyed green. Its fiber consistency shall be approximately 60% fine fiber with the balance being paper particles, 40% of which shall be a diameter of 3 mm minimum and 6 mm maximum. Hydraulic mulch shall be applied at 2,000 kg per 10,000 m². Clean water shall be applied at 42,700 liters per 10,000 m².

Seeding and mulching shall be a one step process in which the seed, fertilizer and hydraulic mulch are applied simultaneously in a water slurry via the hydraulic seeder/mulcher. The materials shall be added to the supply tank while it is being loaded with water. The materials shall be thoroughly mixed into a homogeneous water slurry and shall be distributed uniformly over the prepared surface. The materials shall be measured by mass or by a mass-calibrated volume measurement, acceptable to the Drainage Superintendent.

The hydraulic seeder/mulcher shall be equipped with mechanical agitation equipment capable of mixing the materials into a homogenous state until applied. The discharge pumps and gun nozzles shall be capable of applying the material uniformly.

Grass seed shall be Canada No. 1 grass seed mixture meeting the requirements of a Waterway Slough Mixture as supplied by Growmark or approved equal, as follows:

<i>Creeping Red Fescue</i>	20%
<i>Meadow Fescue</i>	30%
<i>Tall Fescue</i>	30%
<i>Timothy</i>	10%
<i>White Clover</i>	10%

Bags shall bear the label of the supplier indicating the content by species, grade and mass. Seed shall be applied at a rate of 200 kg per 10,000 m².

Fertilizer shall be 8-32-16 applied at 350 kg per 10,000 m². It shall be in granular form, dry, free from lumps and in bags bearing the label of the manufacturer, indicating mass and analysis.

The hydraulic seeding shall be deemed "Completed by the Contractor" when the seed has established in all areas to the satisfaction of the Engineer. Re-seeding and/or other methods required to establish the grass will be given consideration to achieve the end result and the costs shall be incidental to the works.

9.0 GRASS BUFFER STRIPS

Grass buffer strips of 1 metre wide shall be established and preserved immediately adjacent to both banks of the new open channel. Grass buffer strips are to be established as indicated in Section 2.0 'Description of Work'. Establishment of grass buffer strips shall be executed using the same seeding methods as described in Section 10.0.

10.0 SEEDING OF GRASS BUFFER STRIPS

All disturbed grassed areas identified as new or existing grass buffers shall be seeded as specified herein. The existing ground surface to be seeded shall be loosened to a depth of 25 mm and shall be rendered uniformly loose for that 25 mm depth. The surface shall be predominantly fine and free from weeds and other unwanted vegetation. All other loose surface litter shall be removed and disposed of. If mulching is required, it shall be carried out by the contractor as part of the item's tendered price.

Grass seed shall be Canada No. 1 grass seed mixture meeting the requirements of a Waterway Slough Mixture as supplied by Growmark or approved equal, as follows:

<i>Creeping Red Fescue</i>	20%
<i>Meadow Fescue</i>	30%
<i>Tall Fescue</i>	30%
<i>Timothy</i>	10%
<i>White Clover</i>	10%

Bags shall bear the label of the supplier indicating the content by species, grade and mass. Seed shall be applied at a rate of 200 kg per 10,000 m².

Fertilizer shall be 8-32-16 applied at 350 kg per 10,000 m². It shall be in granular form, dry, free from lumps and in bags bearing the label of the manufacturer, indicating mass and analysis.

The seeding shall be deemed "Completed by the Contractor" when the seed has established in all areas to the satisfaction of the Engineer. Re-seeding and/or other methods required to establish the grass will be given consideration to achieve the end result and the costs shall be incidental to the works.

11.0 CLEANING OF PRIVATE ACCESS CULVERTS AND ROAD BRIDGES

At the locations listed below, the Contractor shall clean the existing pipes or culverts to their full capacity and cross section or width. The operation may be carried out by mechanical means or by flushing. Any damage resulting from the Contractor's operation shall be rectified at his expense. All material removed from the pipes or culverts shall be transported to a dump site arranged by the Contractor. The Contractor shall be solely responsible for acquiring all permits required for the dump site. The Contractor shall take precautions during the construction period to avoid re-sedimentation of the pipes and culverts. Any sediment deposited as a result of construction activities shall be removed at the Contractor's expense.

- Bridge No. 5 – Station 1+020, 19 m long, two 1520 mm diameter corrugated

steel pipes (CSP) road culvert.

- Bridge No. 6 – Station 1+109, 7.6 m long, 2240 mm x 1630 mm corrugated steel pipe arch (CSPA) culvert.
- Bridge No. 7 – Station 1+191, 40.5 m long, 2440 mm x 1600 mm corrugated steel pipe arch (CSPA) culvert.
- Bridge No. 13 – Station 2+116, 15.6 m long, 2240 mm x 1630 mm corrugated steel pipe arch (CSPA) road culvert.
- Bridge No. 14 – Station 2+208, 7.8 m long, 2240 mm x 1630 mm corrugated steel pipe arch (CSPA) culvert.
- Bridge No. 15 – Station 2+359, 7.7 m long, 2240 mm x 1630 mm corrugated steel pipe arch (CSPA) culvert.
- Bridge No. 16 – Station 2+445, 7.7m long, 2240 mm x 1630 mm corrugated steel arch pipe (CSPA) culvert.
- Bridge No. 17 – Station 2+567, 7.5 m long, 2240 mm x 1630 mm corrugated steel pipe arch (CSPA) culvert.
- Bridge No. 18 – Station 2+675, 7.6 m long, 2240 mm x 1630 mm corrugated steel pipe arch (CSPA) culvert.
- Bridge No. 20 – Station 3+214, 12 m long, 760 mm diameter corrugated steel pipe (CSP) culvert.

12.0 FARM & UTILITY BRIDGE CONSTRUCTION

12.1 Location of New Bridges

The replacement of Bridge Nos. 1, 3, 6, 7, 14, 15, 17 & 18 inclusive shall be constructed in accordance with the specifications and drawings attached hereto. The centerline of the new culverts shall be located to align with the existing laneway in each case.

12.2 Removal of Existing Bridges

The Contractor shall exercise caution when removing these materials as to minimize damage to the drain banks. Any damage to the drain shall be restored to original conditions at the expense of the Contractor. The removed materials (existing culvert debris and end wall materials) shall be hauled away off-site.

12.3 Materials for New Bridges

Materials shall be as follows:

BRIDGE WITH GRASSED TOP SURFACE (CSPA)

<i>Culvert Pipe</i>	Bridge No. 1 - Station 0+200: <i>New 32 m long, 2500 mm x 1830 mm aluminized Type II corrugated steel pipe arch (CSPA) wall thickness of 3.5 mm and 125 mm x 25 mm corrugations with rerolled ends. New culverts shall be joined with annular aluminized corrugated wide bolt and angle couplers (minimum of 8 corrugation overlap and 3.5 mm wall thickness) and no single pipe less than 6.0 m in length. All pipes connected with couplers shall abut to each other with no more than a 25 mm gap between pipes prior to installation of the coupler and wrapped with filter fabric.</i>
<i>Pipe Bedding Below Pipe</i>	<i>20-25 mm clear stone conforming to OPSS Division 10.</i>
<i>Backfill up to Pipe Culvert Springline</i>	<i>20-25 mm clear stone conforming to OPSS Division 10.</i>
<i>Backfill Above Pipe Springline up to Bottom of Driveway Surface Materials</i>	<i>Dry native material free of topsoil, organic matter, broken concrete, steel, wood and deleterious substances. Alternatively, Granular 'A' or 'B' conforming to OPSS Division 10.</i>
<i>Driveway Surface Erosion Stone</i>	<i>50 mm minimum top soil, fine graded and seeded. All stone to be used for erosion protection shall be 125 - 250 mm clear quarried rock or OPSS.Muni 1004, minimum 300 mm thickness.</i>
<i>Driveway Buffer Strips</i>	<i>Dry native material free of topsoil, organic matter, broken concrete, steel, wood and deleterious substances.</i>
<i>Filter Fabric</i>	<i>"Non-Woven" geotextile filter fabric with a minimum strength equal to or greater than Terrafix 270R, Amoco 4546, Mirafi 140NC or approved equivalent.</i>

BRIDGE WITH ASPHALT TOP SURFACE (CSPA)

<i>Culvert Pipe</i>	Bridge No. 7 - Station 1+191: <i>New 41 m long, 2230 mm x 1700 mm aluminized Type II corrugated steel pipe arch (CSPA) wall thickness of 3.5 mm and 125 mm x 25 mm corrugations with rerolled ends. New culverts shall be joined with annular aluminized corrugated wide bolt and angle couplers (minimum of 8 corrugation overlap and 3.5 mm wall thickness) and no single pipe less than 6.0 m in length. All pipes connected with couplers shall abut to each other with no more than a 25 mm gap between pipes prior to installation of the coupler and wrapped with filter fabric.</i>
<i>Pipe Bedding Below Pipe</i>	<i>20-25 mm clear stone conforming to OPSS Division 10.</i>
<i>Backfill up to Pipe Culvert Springline</i>	<i>20-25 mm clear stone conforming to OPSS Division 10.</i>
<i>Backfill Above Pipe Springline up to Bottom of Driveway Surface Materials</i>	<i>Granular 'A' conforming to OPSS Division 10.</i>
<i>Driveway Surface</i>	<i>40mm HL4 Asphalt, with 60mm HL8 Base Asphalt, crowned for drainage with full compacted granular 'A' backfill below.</i>
<i>Erosion Stone</i>	<i>All stone to be used for erosion protection shall be 125 - 250 mm clear quarried rock or OPSS 1004, minimum 300 mm thickness.</i>
<i>Buffer Strips</i>	<i>Dry native material free of topsoil, organic matter, broken concrete, steel, wood and deleterious substances.</i>
<i>Filter Fabric</i>	<i>"Non-Woven" geotextile filter fabric with a minimum strength equal to or greater than Terrafix 270R, Amoco 4546, Mirafi 140NC or approved equivalent.</i>

BRIDGE WITH GRANULAR TOP SURFACE (CSPA)

<i>Culvert Pipe</i>	Bridge No. 3 - Station 0+825: <i>New 16 m long, 2500 mm x 1830 mm aluminized Type II corrugated steel pipe arch (CSPA) wall thickness of 3.5 mm and 125 mm x 25 mm corrugations with rerolled ends. New culverts shall be joined with annular aluminized corrugated wide bolt and angle couplers (minimum of 8 corrugation overlap and 3.5 mm wall</i>
---------------------	---

thickness) and no single pipe less than 6.0 m in length. All pipes connected with couplers shall abut to each other with no more than a 25 mm gap between pipes prior to installation of the coupler and wrapped with filter fabric.

Bridge No. 6 - Station 1+109: New 14 m long, 2230 mm x 1700 mm aluminized Type II corrugated steel pipe arch (CSPA) wall thickness of 3.5 mm and 125 mm x 25 mm corrugations with rerolled ends. New culverts shall be joined with annular aluminized corrugated wide bolt and angle couplers (minimum of 8 corrugation overlap and 3.5 mm wall thickness) and no single pipe less than 6.0 m in length. All pipes connected with couplers shall abut to each other with no more than a 25 mm gap between pipes prior to installation of the coupler and wrapped with filter fabric.

Bridge No. 14 - Station 2+208: New 16 m long, 2230 mm x 1700 mm aluminized Type II corrugated steel pipe arch (CSPA) wall thickness of 3.5 mm and 125 mm x 25 mm corrugations with rerolled ends. New culverts shall be joined with annular aluminized corrugated wide bolt and angle couplers (minimum of 8 corrugation overlap and 3.5 mm wall thickness) and no single pipe less than 6.0 m in length. All pipes connected with couplers shall abut to each other with no more than a 25 mm gap between pipes prior to installation of the coupler and wrapped with filter fabric.

Bridge No. 15 - Station 2+359: New 16 m long, 2230 mm x 1700 mm aluminized Type II corrugated steel pipe arch (CSPA) wall thickness of 3.5 mm and 125 mm x 25 mm corrugations with rerolled ends. New culverts shall be joined with annular aluminized corrugated wide bolt and angle couplers (minimum of 8 corrugation overlap and 3.5 mm wall thickness) and no single pipe less than 6.0 m in length. All pipes connected with couplers shall abut to each other with no more than a 25 mm gap between pipes prior to installation of the coupler and wrapped with filter fabric.

Bridge No. 17 - Station 2+567: New 16 m long, 2230 mm x 1700 mm aluminized Type II corrugated steel pipe arch (CSPA) wall thickness of 3.5 mm and 125 mm x 25 mm corrugations with rerolled ends. New culverts shall be joined with annular aluminized corrugated wide bolt and angle couplers (minimum of 8 corrugation overlap and 3.5 mm wall thickness) and no single pipe less than 6.0 m in length. All pipes connected with couplers shall abut to each other with no more than a 25 mm gap between pipes prior to installation of the coupler and wrapped with filter fabric.

Bridge No. 18 - Station 2+675: New 16 m long, 2230 mm x 1700 mm aluminized Type II corrugated steel pipe arch (CSPA) wall thickness of 3.5 mm and 125 mm x 25 mm corrugations with rerolled ends. New culverts shall be joined with annular aluminized corrugated wide bolt and angle couplers (minimum of 8 corrugation overlap and 3.5 mm wall thickness) and no single pipe less than 6.0 m in length. All pipes connected with couplers shall abut to each other with no more than a 25 mm gap between pipes prior to installation of the coupler and wrapped with filter fabric.

<i>Pipe Bedding Below Pipe</i>	<i>20-25 mm clear stone conforming to OPSS Division 10.</i>
<i>Backfill up to Pipe Culvert Springline</i>	<i>20-25 mm clear stone conforming to OPSS Division 10.</i>
<i>Backfill Above Pipe Springline up to Bottom of Driveway Surface Materials</i>	<i>Dry native material free of topsoil, organic matter, broken concrete, steel, wood and deleterious substances. Alternatively, Granular 'A' or 'B' conforming to OPSS Division 10.</i>
<i>Driveway Surface</i>	<i>Granular 'A' made from crushed limestone conforming to OPSS Division 10. Minimum 200 mm thickness.</i>
<i>Erosion Stone</i>	<i>All stone to be used for erosion protection shall be 125 - 250 mm clear quarried rock or OPSS 1004, minimum 300 mm thickness.</i>
<i>Buffer Strips</i>	<i>Dry native material free of topsoil, organic matter, broken concrete, steel, wood and deleterious substances.</i>
<i>Filter Fabric</i>	<i>"Non-Woven" geotextile filter fabric with a minimum strength equal to or greater than Terrafix 270R, Amoco 4546, Mirafi</i>

140NC or approved equivalent.

12.4 Culvert Installation

Suitable dykes shall be constructed in the drain so that the installation of the pipe can be accomplished in the dry. The drain bottom shall be cleaned, prepared, shaped and compacted to suit the new culvert configuration, as shown on the drawings. Granular materials shall be compacted to 100% of their maximum dry density; imported clean native materials shall be supplied, placed and compacted to 95% of their maximum dry density.

12.5 Sloping Stone End Walls

Sloping stone end walls shall be constructed of quarry stone rip-rap, as shown on the drawings and as specified in Section 7.0. Each end wall shall extend from the invert of the new culvert to the top of the proposed lane. The end walls shall be sloped 1 vertical to 1.5 horizontal, with a filter fabric underlay surrounding the pipe and spanning across the entire width of the drain. The minimum thickness requirement of the erosion stone layer is 300 mm, with no portion of the filter fabric to be exposed.

12.6 Granular 'A' Driveway

The Contractor shall construct the driveway with a maximum 3% longitudinal grade approach over the new culvert providing a minimum 300 mm cover. This work includes the installation of a minimum 200 mm thickness of compacted Granular 'A' (crushed limestone) surface. The minimum top width of the driveway shall be as shown on the drawings.

12.7 Native Materials

Native materials suitable for use as backfill, as defined under Section 10.2, shall be salvaged from the existing bridge site, as required to complete the work as shown on the drawings, **(Native Backfill Zone only)**. Where there is an insufficient amount of native fill materials for backfilling the culvert, the Contractor may elect to import additional dry native materials or alternatively use Granular 'B' at his/her own expense.

12.8 Lateral Tile Drains

Should the Contractor encounter any lateral tiles within the proposed culvert limits not shown on attached drawings, the Contractor shall re-route the outlet tile drain(s) in consultation with the Drainage Superintendent, as required, to accommodate the

new culvert. **Tile drain outlets through the wall of the new culvert pipe will not be permitted.** All costs associated with re-routing lateral tile drains (if any) shall be at the Contractor's expense.

Care must be taken in handling plastic drain pipe in cold weather to avoid causing damage.

Plastic drain pipe shall be held in position on planned grade immediately after installation by careful placement of backfill material.

13.0 ROAD CROSSING WORK ON OPEN DRAIN

13.1 Existing Structure(s)

The Contractor shall completely remove the existing road bridge(s) as follows:

- **Bridge No. 5** - Station 1+020, (Anchor Drive), consisting of two 19 m long, 1520 mm diameter corrugated steel pipes (CSP) with concrete block end walls.
- **Bridge No. 13** - Station 2+116, (Banwell Road), consisting of a 15.6 m long, 2240 mm x 1630 mm corrugated steel pipe arch (CSPA) with rip rap end protection.
- **Bridge No. 20** – Station 3+214 (Shawnee Road), consisting of a 12 m long, 760 mm diameter corrugated steel pipe (CSP) with rip rap end protection on the pipe outlet and 900 mm diameter CSP catch basin at the pipe inlet.

Dry, native material, free of topsoil, organic matter, broken concrete, steel, wood and deleterious substances may be used as native backfill for the new bridge beyond the limits of the road surface and shoulders. All excess materials removed from the existing bridge structure that are not suitable to use as native backfill, shall be disposed of, off the site. Such materials include rubber tires, poured concrete end walls, broken concrete, stones, wood, metal, etc.

13.2 Location of Bridge Replacement

The bridge replacements shall be located and installed as shown on the drawings.

13.3 Materials for New Bridge

Materials shall be as follows:

Culvert Pipe

Bridge No. 5 - Station 1+020: *Two new 18.0 m long, 1500 mm diameter high quality concrete pipe (CSA A-257.2, Class 65-D) complete with clear stone bedding, full Granular 'A' backfill.*

<i>Pipe Bedding Below Pipe</i>	<i>20-25 mm clear stone conforming to OPSS Division 10.</i>
<i>Backfill up to underside of Roadway Surface</i>	<i>Granular 'A' conforming to OPSS Division 10.</i>
<i>Roadway Surface</i>	<i>40mm HL4 Asphalt, with 60mm HL8 Base Asphalt, crowned for drainage with full compacted granular 'A' backfill below.</i>
<i>Erosion Stone</i>	<i>All stone to be used for erosion protection shall be 125 - 250 mm clear quarried rock or OPSS 1004, minimum 300 mm thickness.</i>
<i>Precast Interlocking Concrete Blocks</i>	<i>New Concrete lock blocks, 600 mm x 600 mm x 3000 mm, 600 mm x 600 mm x 2400 mm, 600 mm x 600 mm x 1200 mm, 600 mm x 600 mm x 600 mm, with filter fabric underlay.</i>
<i>Filter Fabric</i>	<i>"Non-Woven" geotextile filter fabric with a minimum strength equal to or greater than Terrafix 270R, Amoco 4546, Mirafi 140NC or approved equivalent.</i>
<i>Culvert Pipe</i>	Bridge No. 13 - Station 2+116: <i>New 18 m long, 2500 mm x 1830 mm polymer laminated corrugated steel pipe arch (CSPA) wall thickness of 3.5 mm and 125 mm x 25 mm corrugations with rerolled ends. New culverts shall be joined with annular polymer laminated corrugated wide bolt and angle couplers (minimum of 8 corrugation overlap and 3.5 mm wall thickness) and no single pipe less than 6.0 m in length. All pipes connected with couplers shall abut to each other with no more than a 25 mm gap between pipes prior to installation of the coupler and wrapped with filter fabric.</i>
<i>Pipe Bedding Below Pipe</i>	<i>20-25 mm clear stone conforming to OPSS Division 10.</i>
<i>Backfill up to Pipe Culvert Springline</i>	<i>20-25 mm clear stone conforming to OPSS Division 10.</i>
<i>Backfill up to underside of Roadway Surface and Shoulders</i>	<i>Granular 'A' conforming to OPSS Division 10.</i>
<i>Roadway Surface</i>	<i>40mm HL4 Asphalt, with 60mm HL8 Base Asphalt.</i>
<i>Precast Interlocking Concrete Blocks</i>	<i>New Concrete lock blocks, 600 mm x 600 mm x 3000 mm, 600 mm x 600 mm x 1200 mm, 600 mm x 600 mm x 600 mm, with</i>

	<i>filter fabric underlay.</i>
<i>Erosion Stone</i>	<i>All stone to be used for erosion protection shall be 125 - 250 mm clear quarried rock or OPSS 1004, minimum 300 mm thickness.</i>
<i>Buffer Strips</i>	<i>Dry native material free of topsoil, organic matter, broken concrete, steel, wood and deleterious substances.</i>
<i>Filter Fabric</i>	<i>"Non-Woven" geotextile filter fabric with a minimum strength equal to or greater than Terrafix 270R, Amoco 4546, and Mirafi 140NC or approved equivalent.</i>
<i>Culvert Pipe</i>	Bridge No. 20 - Station 3+214: <i>New 12 m long, 750 mm diameter polymer laminated corrugated steel pipe (CSP) wall thickness of 2.8 mm and 68 mm x 13 mm corrugations with rerolled ends. New culverts shall be joined with annular polymer laminated corrugated wide bolt and angle couplers (minimum of 8 corrugation overlap and 2.8 mm wall thickness) and no single pipe less than 6.0 m in length. All pipes connected with couplers shall abut to each other with no more than a 25 mm gap between pipes prior to installation of the coupler and wrapped with filter fabric.</i>
<i>Pipe Bedding Below Pipe</i>	<i>20-25 mm clear stone conforming to OPSS Division 10.</i>
<i>Backfill up to Pipe Culvert Springline</i>	<i>Granular 'A' conforming to OPSS Division 10.</i>
<i>Backfill up to underside of Roadway Surface and Shoulders</i>	<i>Granular 'A' conforming to OPSS Division 10.</i>
<i>Backfill up to underside of Surface material outside of roadway</i>	<i>Dry native material free of topsoil, organic matter, broken concrete, steel, wood and deleterious substances. Alternatively, the Contractor may elect to use full compacted granular 'A' backfill at their expense.</i>
<i>Roadway Surface</i>	<i>40mm HL4 Asphalt, with 60mm HL8 Base Asphalt.</i>
<i>Grassed Surface outside of roadway</i>	<i>50 mm minimum top soil, fine graded and seeded</i>
<i>Erosion Stone</i>	<i>All stone to be used for erosion protection shall be 125 - 250 mm clear quarried rock or OPSS 1004, minimum 300 mm thickness.</i>

<i>Buffer Strips</i>	<i>Dry native material free of topsoil, organic matter, broken concrete, steel, wood and deleterious substances.</i>
<i>Filter Fabric</i>	<i>"Non-Woven" geotextile filter fabric with a minimum strength equal to or greater than Terrafix 270R, Amoco 4546, and Mirafi 140NC or approved equivalent.</i>

13.4 Lateral Tile Drains

Should the Contractor encounter any lateral tiles within the proposed culvert limits not shown on attached drawings, the Contractor shall re-route the outlet tile drain(s) in consultation with the Drainage Superintendent, as required, to accommodate the new culvert. **Tile drain outlets through the wall of the new culvert pipe will not be permitted.** All costs associated with re-routing lateral tile drains (if any) shall be at the Contractor's expense.

13.5 Culvert Installation

Suitable dykes shall be constructed in the drain so that the installation of the pipe can be accomplished in the dry. The drain bottom shall be cleaned, prepared, shaped and compacted to suit the new culvert configuration, as shown on the drawings. Granular materials shall be compacted to 100% of their maximum dry density; native materials shall be compacted to 95% of their maximum dry density.

13.6 Vertical Concrete Lock Block End Walls (Bridge No. 5 & Bridge No. 13)

End walls shall be constructed of interlocking concrete blocks as shown on the attached drawings using 600 mm wide x 600 mm high x 1200 mm long blocks. Where specified, the contractor shall make use of half blocks (600 mm x 600 mm x 600 mm), 3000 mm long blocks (600 mm x 600 mm x 3000 mm), and 2400 mm long blocks (600 mm x 600 mm x 2400 mm). Each end wall shall extend from the invert of the new culvert to the top of the proposed driveway. The concrete block end walls shall be set at a 10:1(V:H) batter. The concrete block end walls shall be keyed into the existing drain banks and provided with a filter fabric backing to separate the backfill materials from the concrete blocks. All void space between the culvert and the concrete blocks shall be filled with concrete minimum 30 MPa compressive strength.

Other styles and sizes of concrete blocks may be considered for the construction of the end walls. If the Contractor wishes to use concrete blocks that vary from the style or size specified, he/she shall submit the manufacturers block Specifications and an intended block layout plan to the Drainage Superintendent and/or the Engineer prior to commencing construction. Any additional costs incurred from the use of alternative blocks shall be the Contractor's responsibility.

13.7 Native Materials

Native materials suitable for use as backfill, as defined under Section 13.3, shall be salvaged from the existing bridge site as required to complete the work as shown on the drawings. Any surplus native materials (if any) not required in the bridge installation shall be managed by the Contractor at their expense in accordance with Section 16.2.

13.8 Relocation of Existing Road Crossing (Bridge No. 5)

The Contractor shall relocate the existing 750 mm diameter corrugated steel pipe crossing Anchor Drive into the Gouin Drain as shown on the drawings. The Contractor shall supply and install a 450 CSP 'elbow' and a concrete 1500 mm x 750 mm 'tee' as necessary to complete the connection.

13.9 Driveway Restoration

The Contractor shall construct the driveway as shown on the drawings. This work includes the removal of topsoil, placement of compacted native material, and the installation of a minimum of 200 mm of compacted Granular 'A' surface (crushed limestone). The width of the driveway and layout of gravel surface shall be as shown on the drawings.

13.10 Site Cleanup and Restoration

As part of the work and upon completion, the Contractor shall remove and dispose of, off-site any loose timber, logs, stumps, large stones, rubber tires, cinder blocks or other debris from the drain bottom and from the side slopes. Where the construction works cross a lawn, the Contractor shall take extreme care to avoid damaging the lawn, shrubs and trees encountered. Upon completion of the work, the Contractor shall completely restore the area by the placement and fine grading of topsoil and seeding or sodding the area as specified by the Engineer or Drainage Superintendent.

14.0 NEW CATCH BASINS

The Contractor shall arrange for the supply and installation of pre-cast concrete catch basins at the locations and elevations as shown on the plans and profiles.

The Contractor shall install all precast structures plumb and true to line and grade. Precast bases shall be set to the specified grade, shall be level, and shall have uniform overall contact with the underlying soil.

All catch basins installed shall meet the dimensions and locations outlined in the drawings. Precast concrete catch basins shall conform to the requirements of

Ontario Provincial Standard Specification (OPSS 1351). The floor elevation shall be at least 300 mm below the invert of the outlet pipe in the wall of the catch basin.

Pipe placed in the walls for inlet and outlet connections shall extend through the wall a sufficient distance to allow for connections. The pipes shall be trimmed flush with the inside wall and shall be securely sealed into place using grout.

All catch basins shall be manufactured to allow for a minimum 150 mm height of riser adjustment rings to permit elevation modifications if required.

Catch basins shall be backfilled with clean native material in maximum 300 mm lifts and compacted to 98% of the maximum standard proctor density.

13.11 Catch Basin No. 1 to No. 3 (Gouin Drain Branch North)

Catch basin No. 1 to No. 3 shall be as per OPSD 705.010 and be supplied with cast iron frame and grate as per OPSD 400.02.

13.12 Catch Basin No. 11 (Shawnee Road)

Catch basin No. 11 shall be 900 mm x 1200 mm in size, and be supplied with a heavy duty galvanized steel flap top grate, both as manufactured by Coldstream Concrete or approved equal. The grate is to be equipped with fasteners to secure the grate to the catch basin as supplied by the manufacture.

Existing pipes within CB11 are to be reconnected to the new catch basin with new BOSS 2000 HDPE pipes and Fernco couplers, or approved equivalents.

15.0 REPLACEMENT AND SLIP-LINING OF ENCLOSED DRAIN

The Contractor shall repair the Gouin Drain Branch North as outlined on the drawings appended hereto to the dimensions and location shown. Prior to work, the Contractor shall remove and dispose of existing catch basin maintenance hole at CB3 location, and prepare existing 1050 mm diameter corrugated steel pipe for repair by cutting out a section of pipe in order to receive the proposed pre-cast concrete catch basin. The Contractor shall take care not to damage existing backyard structures. Cost to repair damaged property shall be at the Contractor's expense.

15.1 Pipe Slip-Lining (Station 0+091A to Station 0+133A)

The Contractor shall slip-line the existing 1050 mm diameter corrugated steel pipe between Station 0+091A and Station 0+133A with a 300 mm diameter high density polyethylene, smooth wall pipe positioned so the bottom of the 300 mm diameter pipe meets the invert of the 1050 mm diameter pipe along the entire length of the pipe.

Work includes fixing the new 300 mm diameter pipe to the existing 1050 mm diameter pipe and filling voids between pipes with non-shrink flowable backfill material. The non-shrink backfill shall consist of pre-mixed sand and Portland cement slurry provided by the concrete truck with pumping unit. The Contractor shall confirm with the owners and Municipality that all private drain connections to the old pipe have been found and are connected to the new 300 mm diameter HDPE pipe prior to infilling.

15.2 Pipe Replacement (Station 0+079A to Station 0+091A)

The Contractor shall remove and dispose of the existing 1050 mm diameter corrugated steel pipe from the proposed location of the new catch basin (CB1) at Station 0+091A to the downstream end of the 1050 mm diameter pipe where the Contractor shall expose and connect to the existing 300 mm diameter plastic pipe using a Fernco coupler.

15.3 Drainage Pipe Materials

15.3.1 H.D.P.E. Pipe

<i>Gouin Drain Branch North (Sta. 0+064A to Sta. 0+113A)</i>	<i>New 300 mm (12”) diameter solid (non-perforated) corrugated High Density Polyethylene (H.D.P.E.) smooth wall interior (Armtec Boss 2000 or approved equivalent) unless otherwise specified conforming to the following specifications: ASTM @3350, CSA B182.8-02 and OPSS 1840. The pipe is to provide a minimum pipe stiffness of 320 kPa. Joined using (soil tight) “gasketed bell & spigot” Ultra Stab joining system (as manufactured by Armtec Limited or approved equal), supplied by the pipe manufacturer and conforming to ASTM D3350, CSA 182.8-02 and OPSS 1840.</i>
<i>Pipe Bedding</i>	<i>Granular ‘B’ conforming to OPSS Division 10 to springline of pipe.</i>
<i>Backfill except under driveways</i>	<i>Dry native material free of topsoil, organic matter, broken concrete, steel, wood and deleterious substances.</i>
<i>Topsoil Surface</i>	<i>Salvaged topsoil minimum 100 mm thickness.</i>

15.4 Site Cleanup and Restoration

The Contractor shall reinstate the property fence lines that were removed in order to

access the work. As part of the work and upon completion, the Contractor shall remove and dispose of, off-site any loose timber, logs, stumps, large stones, rubber tires, cinder blocks or other debris from the drain bottom and from the side slopes. Where the construction works cross a lawn, the Contractor shall take extreme care to avoid damaging the lawn, shrubs and trees encountered. Upon completion of the work, the Contractor shall completely restore the area by the placement and fine grading of topsoil and seeding or sodding the area as specified by the Engineer or Drainage Superintendent.

16.0 TEMPORARY CONSTRUCTION FENCING

The Contractor shall erect, maintain and relocate as necessary to suit construction, 1.8 metre tall rigid temporary construction fencing to meet the requirements of the Ministry of Labour. The fencing is to surround the working corridor between Stations 0+079A and 0+133A of Gouin Drain Branch North. The Contractor will ensure that sufficient labour is provided to maintain the fencing on a daily basis, as well as to relocate the fencing as considered necessary to complete the work.

17.0 ON-SITE AND EXCESS SOIL MANAGEMENT

The Contractor's attention is hereby drawn to the fact that construction of this Contract will necessitate special measures being taken with respect to the management of on-site and excess soil to meet the requirements of Ontario Regulation 406/19 On-Site and Excess Soil Management and supporting documents, in particular the Rules for Soil Management and Excess Soil Quality Standards, MECP, December 2019.

The Contractor shall prepare an excavation contingency plan in compliance with Section 23 of O.Reg. 406/19 and submit the procedure to the Owner for review and approval prior to excavating any soil in the Project Area.

The Contractor is responsible for ensuring that any vehicle hauling excess soil from the project area meets the criteria listed in Section 17 of O.Reg. 406/19 and can provide the information set out in Section 18 of O.Reg. 406/19 upon request.

Excavated material originating from the drain between Station 1+109 and Station 3+286 may be handled according to Schedule 2, Section 3, paragraph 6 of O.Reg. 406/19. Should the abutting landowner request the excavated material to remain on site, the Contractor shall transport the excavated material to a location specified by the Drainage Superintendent within the abutting lands.

In general, on-site storage will not be permitted, unless special approval is provided by the Town. If required and approved, on-site soil storage shall comply with the Soil

Storage Rules set out in Section C of the Rules for Soil Management and Excess Soil Quality Standards.

17.1 Chemical Soils Analysis and Results

An Environmental Review Report and Soil Characterization Report (both dated April 26, 2021) have been prepared for the Project Area.

As described in the Soil Characterization Report, soils excavated between Station 0+163 and Station 1+020 are recommended to be managed as follows:

- Soils between TP-101 and TP-105 may be reused at a receiving site that accepts soils meeting Table 3.1 Residential, Parkland and Institutional (RPI) and/or Table 3.1 Industrial, Commercial and Community (ICC) Excess Soil Quality Standards (ESQS), with salt parameter exemptions, pending review and acceptance by the reviewer. These soils are not suitable for receivers that do not accept salt-impacted soils. Part I Section D.1 (3) of the Rules for Soil Management and Excess Soil Quality Standards prescribed the following reuse conditions for excess soil with salt (sodium adsorption ratio and electrical conductivity) impacts.
 - The excess soil is finally placed at one of the following locations:
 - Where it is reasonable to expect that the soil will be affected by the same chemicals as a result of continued application of a substance for the safety of vehicular or pedestrian traffic under conditions of snow or ice;
 - At an industrial or commercial property use and to which non-potable standards would be applicable; or
 - At least 1.5 metres below the surface of the soil.
 - The excess soil is not finally placed at any of the following locations:
 - Within 30 metres of a waterbody;
 - Within 100 metres of a potable water well or area with an intended property use that may require a potable water well; or
 - A location that will be used for growing crops or pasturing livestock unless the excess soil is placed 1.5 metres or greater below the soil surface.
 - The project leader or operator of the Project Area has informed the reuse site owner or operator that the excess soil is from a location that may be expected to contain the chemical and, if sampling and

analysis has been conducted in accordance with the Regulation, the project leader or operator of the Project Area has provided relevant sampling results to the reuse site owner or operator, including the soil characterization report if prepared, and identified and communicated any potential risks to surface water and ground water to the reuse site owner or operator.

Soils east of TP-105 contain exceedances of the Table 3.1 RPI and ICC ESQS for non-salt related parameters (i.e., cyanide, zinc and petroleum hydrocarbons (PHCs), fractions F2 and F3). These soils are not isolated to a single location and are present throughout this zone. These soils are not suitable for reuse and will require management as waste at an appropriate facility.

Should construction extend west of TP-101, based on the heterogeneity of the soil quality observed and absence of sampling data west of TP-101, these soils should be managed as waste.

If construction constraints do not allow for the segregation of soils between TP-101 and TP-105, all soils are to be managed as waste.

The Contractor shall not claim any misunderstanding with regard to subsurface physical or chemical conditions provided in the reports for this contract. No claims related to Contract delays while obtaining an approved disposal/reuse site will be paid to the Contractor.

17.2 Excess Excavated Material

Material excavated in carrying out the work of the various tender items included in this Contract which is surplus to the requirements of the Contract shall be reused offsite at the Contractor's expense in accordance with OPSS 180. It is the Contractor's responsibility to find a suitable reuse site and no claims related to Contract delays while obtaining an approved reuse site will be paid to the Contractor. Any additional chemical testing required by reuse sites shall be at the Contractor's expense. The Contractor shall determine the appropriate reuse site and all costs associated with the disposal shall be at the Contractor's expense.

All excess soils must be finally placed within a period of 90 days following excavation.

The Contractor shall provide the Contract Administrator with a copy of OPSF 180-2 form, "SITE SELECTION NOTIFICATION FOR MATERIAL MANAGED AS DISPOSABLE FILL" as well as a copy of OPSF 180-3 form, "PROPERTY OWNER'S RELEASE" two weeks prior to the start of excavation activities. The Contractor shall certify that soil

reuse sites can accept the volume and quality of excess soil being transported from the project area. The Contractor is not permitted to start any excavation works until these forms have been signed and provided the Contract Administrator.

This item applies to any item that includes excavation, removal and reuse of excess material. All costs associated with the requirements of this special provision are to be included within the unit prices for those items.

17.3 Payment

There is no payment associated with this special provision. The costs associated with these requirements are to be included within the unit prices for the items which require excess materials management.

GENERAL SPECIFICATIONS

1.0 AGREEMENT AND GENERAL CONDITIONS

The part of the Specifications headed "Special Provisions" which is attached hereto forms part of this Specification and is to be read with it. Where there is any difference between the requirements of this General Specification and those of the Special Provisions, the Special Provisions shall govern.

Where the word "Drainage Superintendent" is used in this specification, it shall mean the person or persons appointed by the Council of the Municipality having jurisdiction to superintend the work.

Tenders will be received and contracts awarded only in the form of a lump sum contract for the completion of the whole work or of specified sections thereof. The Tenderer agrees to enter into a formal contract with the Municipality upon acceptance of the tender. The General Conditions of the contract and Form of Agreement shall be those of the Stipulated Price Contract CCDC2-Engineers, 1994 or the most recent revision of this document.

2.0 EXAMINATION OF SITE, PLANS AND SPECIFICATIONS

Each tenderer must visit the site and review the plans and specifications before submitting his/her tender and must satisfy himself/herself as to the extent of the work and local conditions to be met during the construction. Claims made at any time after submission of his/her tender that there was any misunderstanding of the terms and conditions of the contract relating to site conditions, will not be allowed. The Contractor will be at liberty, before bidding to examine any data in the possession of the Municipality or of the Engineer.

The quantities shown or indicated on the drawings or in the report are estimates only and are for the sole purpose of indicating to the tenderers the general magnitude of the work. The tenderer is responsible for checking the quantities for accuracy prior to submitting his/her tender.

3.0 MAINTENANCE PERIOD

The successful Tenderer shall guarantee the work for a period of one (1) year from the date of acceptance thereof from deficiencies that, in the opinion of the Engineer, were caused by faulty workmanship or materials. The successful Tenderer shall, at his/her own expense, make good and repair deficiencies and every part thereof, all to the satisfaction of the Engineer. Should the successful Tenderer for any cause, fail

to do so, then the Municipality may do so and employ such other person or persons as the Engineer may deem proper to make such repairs or do such work, and the whole costs, charges and expense so incurred may be deducted from any amount due to the Tenderer or may be collected otherwise by the Municipality from the Tenderer.

4.0 GENERAL CO-ORDINATION

The Contractor shall be responsible for the coordination between the working forces of other organizations and utility companies in connection with this work. The Contractor shall have no cause of action against the Municipality or the Engineer for delays based on the allegation that the site of the work was not made available to him by the Municipality or the Engineer by reason of the acts, omissions, misfeasance or non-feasance of other organizations or utility companies engaged in other work.

5.0 RESPONSIBILITY FOR DAMAGES TO UTILITIES

The Contractor shall note that overhead and underground utilities such as hydro, gas, telephone and water are not necessarily shown on the drawings. It is the Contractor's responsibility to contact utility companies for information regarding utilities, to exercise the necessary care in construction operations and to take other precautions to safeguard the utilities from damage. All work on or adjacent to any utility, pipeline, railway, etc., is to be carried out in accordance with the requirements of the utility, pipeline, railway, or other, as the case may be, and its specifications for such work are to be followed as if they were part of this specification. The Contractor will be liable for any damage to utilities.

6.0 CONTRACTOR'S LIABILITY

The Contractor, his/her agents and all workmen or persons under his/her control including sub-contractors, shall use due care that no person or property is injured and that no rights are infringed in the prosecution of the work. The Contractor shall be solely responsible for all damages, by whomsoever claimable, in respect to any injury to persons or property of whatever description and in respect of any infringement of any right, privilege or easement whatever, occasioned in the carrying on of the work, or by any neglect on the Contractor's part.

The Contractor, shall indemnify and hold harmless the Municipality and the Engineer, their agents and employees from and against claims, demands, losses, costs, damages, actions, suits, or proceedings arising out of or attributable to the Contractor's performance of the contract.

7.0 PROPERTY BARS AND SURVEY MONUMENTS

The Contractor shall be responsible for marking and protecting all property bars and survey monuments during construction. All missing, disturbed or damaged property bars and survey monuments shall be replaced at the Contractor's expense, by an Ontario Land Surveyor.

8.0 MAINTENANCE OF FLOW

The Contractor shall, at his/her own cost and expense, permanently provide for and maintain the flow of all drains, ditches and water courses that may be encountered during the progress of the work.

9.0 ONTARIO PROVINCIAL STANDARDS

Ontario Provincial Standard Specifications (OPSS) and Ontario Provincial Standard Drawings (OPSD) shall apply and govern at all times unless otherwise amended or extended in these Specifications or on the Drawing. Access to the electronic version of the Ontario Provincial Standards is available online through the MTO website, free of charge to all users. To access the electronic standards on the Web, go to <http://www.mto.gov.on.ca/english/transrd/>. Under the title Technical Manuals is a link to the Ontario Provincial Standards. Users require Adobe Acrobat to view all pdf files.

10.0 APPROVALS, PERMITS AND NOTICES

The construction of the works and all operations connected therewith are subject to the approval, inspection, by-laws and regulations of all Municipal, Provincial, Federal and other authorities having jurisdiction in respect to any matters embraced in this Contract. The Contractor shall obtain all approvals and permits and notify the affected authorities when carrying out work in the vicinity of any public utility, power, underground cables, railways, etc.

11.0 SUBLETTING

The Contractor shall keep the work under his/her personal control, and shall not assign, transfer, or sublet any portion without first obtaining the written consent of the Municipality.

12.0 TIME OF COMPLETION

The Contractor shall complete all work on or before the date fixed at the time of tendering. The Contractor will be held liable for any damages or expenses occasioned by his/her failure to complete the work on time and for any expenses of inspection, superintending, re-tendering or re-surveying, due to their neglect or failure to carry out the work in a timely manner.

13.0 TRAFFIC CONTROL

The Contractor will be required to control vehicular and pedestrian traffic along roads at all times and shall, at his/her own expense, provide for placing and maintaining such barricades, signs, flags, lights and flag persons as may be required to ensure public safety. The Contractor will be solely responsible for controlling traffic and shall appoint a representative to maintain the signs and warning lights at night, on weekends and holidays and at all other times that work is not in progress. All traffic control during construction shall be strictly in accordance with the **Occupational Health and Safety Act** and the current version of the **Ontario Traffic Manuals**. Access to the electronic version of the **Ontario Traffic Manual** is available online through the MTO website, free of charge to all users. To access the electronic standards on the Web, go to <http://www.mto.gov.on.ca/english/transrd/>, click on "Library Catalogue," under the "Title," enter "Ontario Traffic Manual" as the search. Open the applicable "Manual(s)" by choosing the "Access Key," once open look for the "Attachment," click the pdf file. Users require Adobe Acrobat to view all pdf files.

Contractors are reminded of the requirements of the Occupational Health and Safety Act pertaining to Traffic Protection Plans for workers and Traffic Control Plan for Public Safety.

14.0 SITE CLEANUP AND RESTORATION

As part of the work and upon completion, the Contractor shall remove and dispose of, off-site any loose timber, logs, stumps, large stones, rubber tires, cinder blocks or other debris from the drain bottom and from the side slopes. Where the construction works cross a lawn, the Contractor shall take extreme care to avoid damaging the lawn, shrubs and trees encountered. Upon completion of the work, the Contractor shall completely restore the area by the placement and fine grading of topsoil and seeding or sodding the area as specified by the Engineer or Drainage Superintendent.

15.0 UTILITY RELOCATION WORKS

In accordance with Section 26 of the Drainage Act, if utilities are encountered during the installation of the drainage works that conflict with the placement of the new culvert, the operating utility company shall relocate the utility at their own costs. The Contractor however will be responsible to co-ordinate these required relocations (if any) and their co-ordination work shall be considered incidental to the drainage works.

16.0 FINAL INSPECTION

All work shall be carried out to the satisfaction of the Drainage Superintendent for the Municipality, in compliance with the specifications, drawings and the Drainage Act. Upon completion of the project, the work will be inspected by the Engineer and the Drainage Superintendent. Any deficiencies noted during the final inspection shall be immediately rectified by the Contractor.

Final inspection will be made by the Engineer within 20 days after the Drainage Superintendent has received notice in writing from the Contractor that the work is completed, or as soon thereafter as weather conditions permit.

17.0 FISHERIES CONCERNS

Standard practices to be followed to minimize disruption to fish habitat include embedment of the culvert a minimum 10% below grade, constructing the work 'in the dry' and cutting only trees necessary to do the work (no clear-cutting). No in-water work is to occur during the timing window unless otherwise approved by the appropriate authorities.

LEGEND

- MUNICIPAL BOUNDARY
- GOUIN DRAIN DRAINAGE AREA BOUNDARY
- GOUIN BRANCH DRAIN DRAINAGE AREA BOUNDARY
- GOUIN DRAIN
- OTHER DRAINS
- SUBWATERSHED
- BRIDGE REPLACEMENT
- FUTURE BRIDGE REPLACEMENT
- EXISTING BRIDGE
- BRIDGE REMOVAL
- BLOCK 'A' ASSESSMENT
- BLOCK 'B' ASSESSMENT
- BLOCK 'D' ASSESSMENT
- BLOCK 'E' ASSESSMENT
- WOODLOT
- LOCAL BENCHMARK

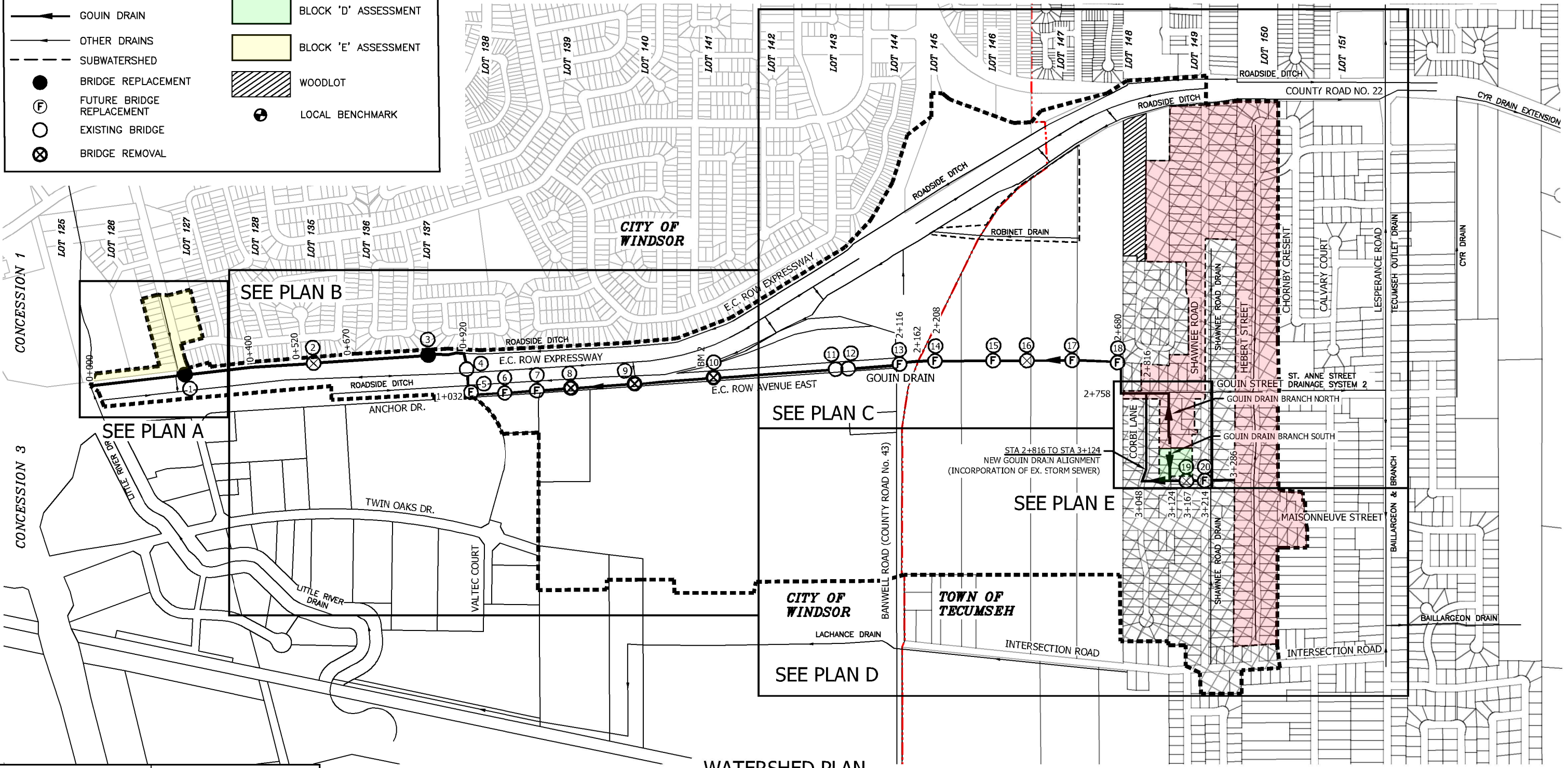

WATERSHED PLAN
SCALE=1:10,000

'SCHEDULE G'

Jan 20, 2023 - 10:04am C:\pwworking\directory\projects to 2017\330aem\0611685\176773-03-DRN-CON.dwg



Conditions of Use

Verify elevations and/or dimensions on drawing prior to use. Report any discrepancies to Dillon Consulting Limited.

Do not scale dimensions from drawing.

Do not modify drawing, re-use it, or use it for purposes other than those intended at the time of its preparation without prior written permission from Dillon Consulting Limited.

No.	ISSUED FOR	DATE	BY
3	FINAL REPORT SUBMISSION	20 JAN 23	MDH
2	PUBLIC INFORMATION CENTRE	25 MAR 22	MDH
1	CLIENT REVIEW	4 MAR 22	MDH

DESIGN	MDH	REVIEWED BY	CDP
DRAWN	KAW/OEM	CHECKED BY	TRO
DATE	January 20, 2023		
SCALE	AS SHOWN		

PROJECT NO. 17-6773

DRAWING SCALES BASED ON A 11" X 17" SHEET

Drainage Report for the
GOUIN DRAIN
Town of Tecumseh & City of Windsor

SHEET TITLE
OVERALL WATERSHED PLAN

PAGE NO.
1 of 21

LEGEND

- MUNICIPAL BOUNDARY
- GOUIN DRAIN DRAINAGE AREA BOUNDARY
- GOUIN BRANCH DRAIN DRAINAGE AREA BOUNDARY
- GOUIN DRAIN
- OTHER DRAINS
- SUBWATERSHED
- BLOCK 'E' ASSESSMENT
- BRIDGE REPLACEMENT
- FUTURE BRIDGE REPLACEMENT
- EXISTING BRIDGE
- BRIDGE REMOVAL
- LOCAL BENCHMARK



NOTES:
1. BENCHMARK INFORMATION ON SHEET 13

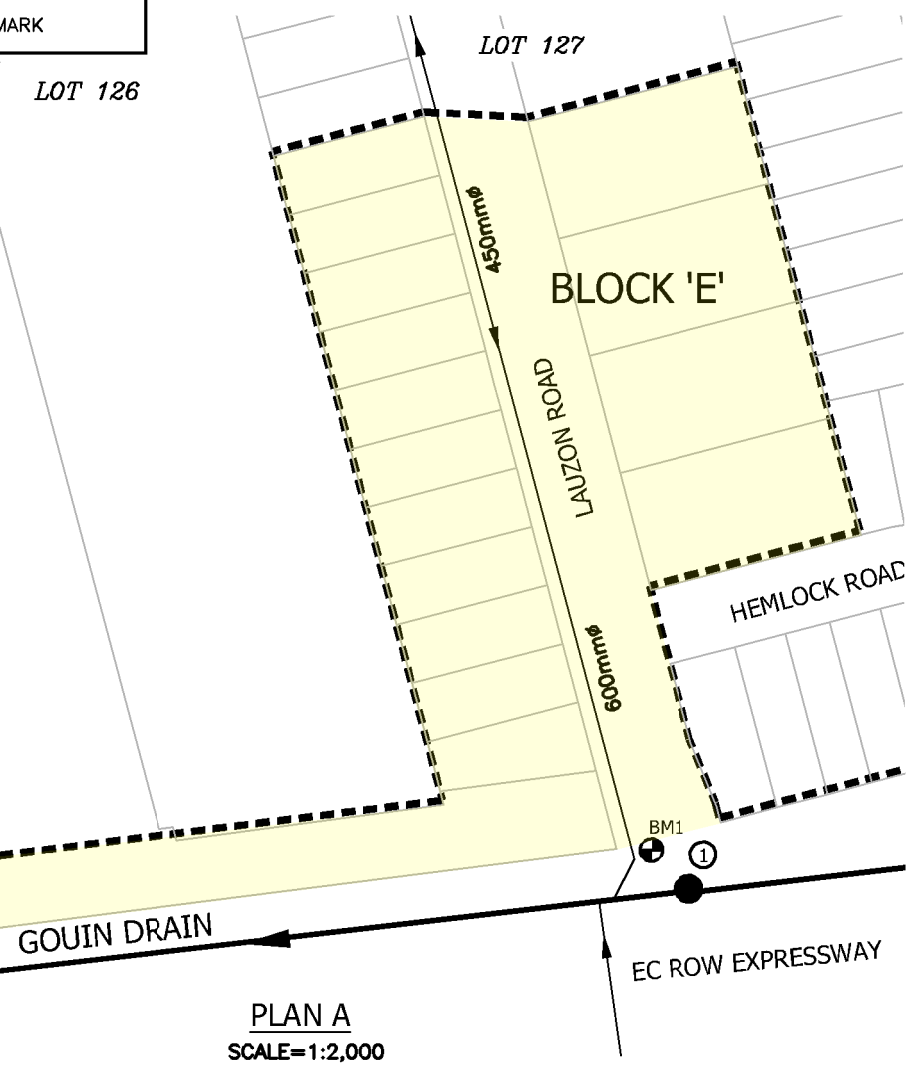
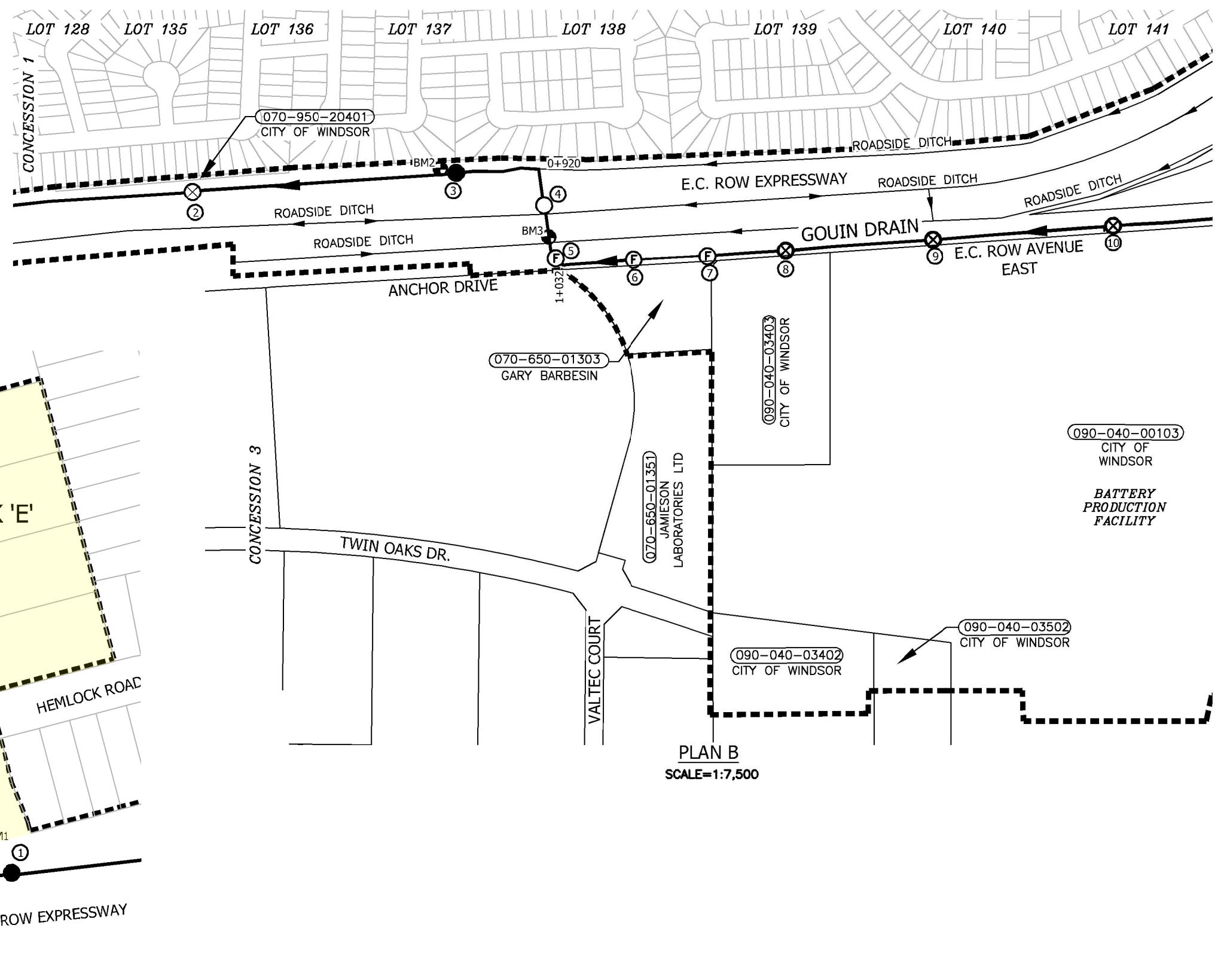

PLAN B
SCALE=1:7,500

Jan 20, 2023 - 10:04am C:\pw working directory\projects to 2017\33sem\40611685\76773-03-DRN-CON.dwg



Conditions of Use

Verify elevations and/or dimensions on drawing prior to use. Report any discrepancies to Dillon Consulting Limited.

Do not scale dimensions from drawing.

Do not modify drawing, re-use it, or use it for purposes other than those intended at the time of its preparation without prior written permission from Dillon Consulting Limited.

No.	ISSUED FOR	DATE	BY
3	FINAL REPORT SUBMISSION	20 JAN 23	MDH
2	PUBLIC INFORMATION CENTRE	25 MAR 22	MDH
1	CLIENT REVIEW	4 MAR 22	MDH

DESIGN	MDH	REVIEWED BY	CDP
DRAWN	KAW/OEM	CHECKED BY	TRO
DATE	January 20, 2023		
SCALE	AS SHOWN		

PROJECT NO. 17-6773

DRAWING SCALES BASED ON A 11" X 17" SHEET

'SCHEDULE G'

Drainage Report for the
GOUIN DRAIN
Town of Tecumseh & City of Windsor

SHEET TITLE: **PLAN A & B**

PAGE NO.: 2 of 21

LEGEND

- MUNICIPAL BOUNDARY
- GOUIN DRAIN DRAINAGE AREA BOUNDARY
- GOUIN BRANCH DRAIN DRAINAGE AREA BOUNDARY
- GOUIN DRAIN
- OTHER DRAINS
- SUBWATERSHED
- BLOCK 'A' ASSESSMENT
- BLOCK 'B' ASSESSMENT
- BLOCK 'D' ASSESSMENT
- WOODLOT
- BRIDGE REPLACEMENT
- FUTURE BRIDGE REPLACEMENT
- EXISTING BRIDGE
- BRIDGE REMOVAL
- LOCAL BENCHMARK

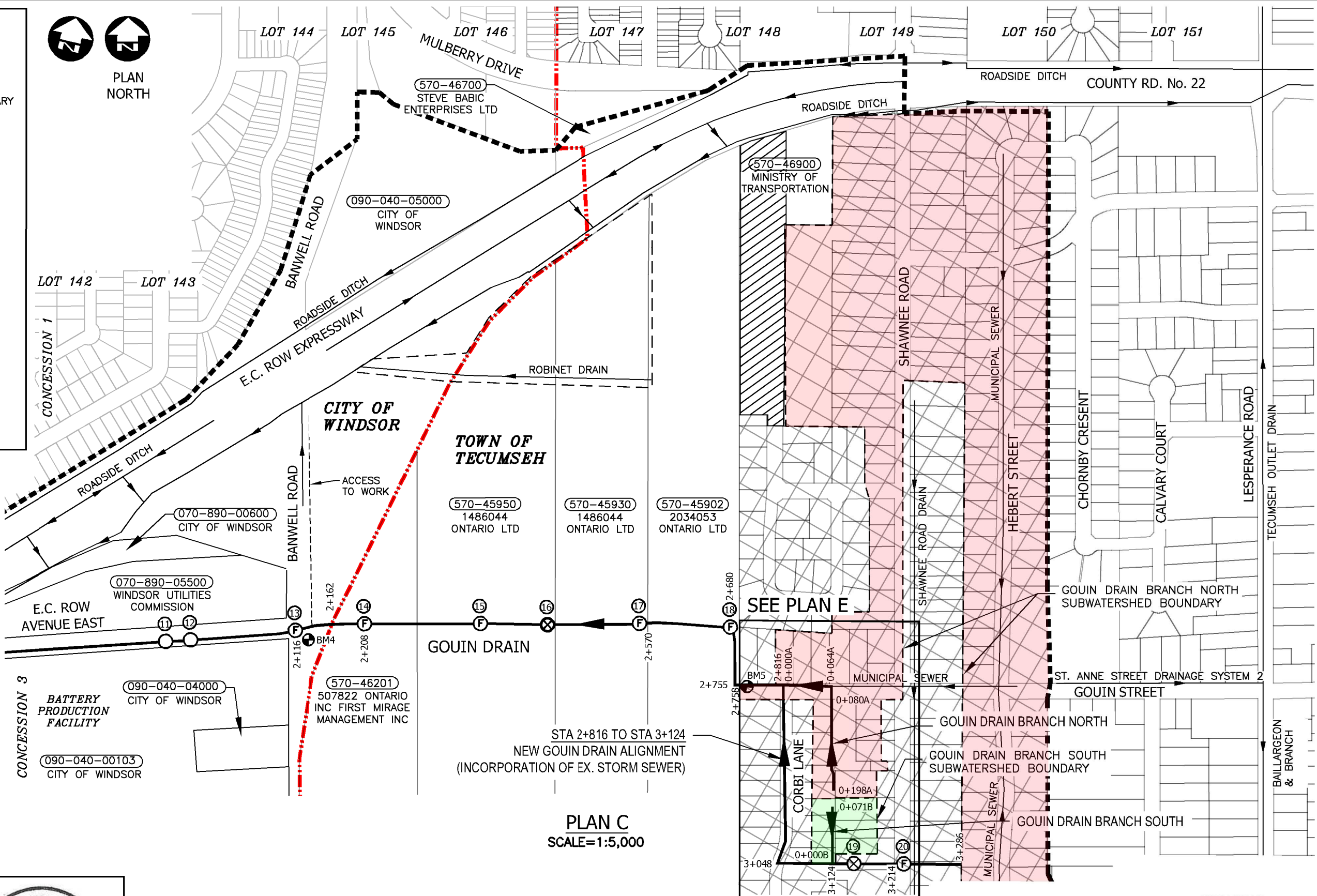

- NOTES:**
- BENCHMARK INFORMATION ON SHEET 13.
 - BRIDGE 16 IS TO BE REMOVED IN THE FUTURE AND IS NOT PART OF THE WORK.

PLAN C
SCALE=1:5,000

Jan 20, 2023 - 10:04am C:\pwworking\directory\projects to 2017\330am\0611685\176773-03-DRN-CON.dwg



Conditions of Use

Verify elevations and/or dimensions on drawing prior to use. Report any discrepancies to Dillon Consulting Limited.

Do not scale dimensions from drawing.

Do not modify drawing, re-use it, or use it for purposes other than those intended at the time of its preparation without prior written permission from Dillon Consulting Limited.

No.	ISSUED FOR	DATE	BY
3	FINAL REPORT SUBMISSION	20 JAN 23	MDH
2	PUBLIC INFORMATION CENTRE	25 MAR 22	MDH
1	CLIENT REVIEW	4 MAR 22	MDH

DESIGN	REVIEWED BY
MDH	CDP
DRAWN	CHECKED BY
KAW/OEM	TRO
DATE	January 20, 2023
SCALE	AS SHOWN

PROJECT NO. 17-6773

DRAWING SCALES BASED ON A 11" X 17" SHEET













'SCHEDULE G'

Drainage Report for the
GOUIN DRAIN
Town of Tecumseh & City of Windsor

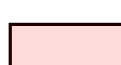
SHEET TITLE: **PLAN C**

PAGE NO.: 3 of 21

LEGEND

-  MUNICIPAL BOUNDARY
-  GOUIN DRAIN DRAINAGE AREA BOUNDARY
-  GOUIN BRANCH DRAIN DRAINAGE AREA BOUNDARY
-  GOUIN DRAIN
-  OTHER DRAINS
-  SUBWATERSHED
-  BLOCK 'A' ASSESSMENT
-  BLOCK 'B' ASSESSMENT
-  BRIDGE REPLACEMENT
-  FUTURE BRIDGE REPLACEMENT
-  EXISTING BRIDGE
-  BRIDGE REMOVAL
-  LOCAL BENCHMARK



NOTES:
1. BENCHMARK INFORMATION ON SHEET 13

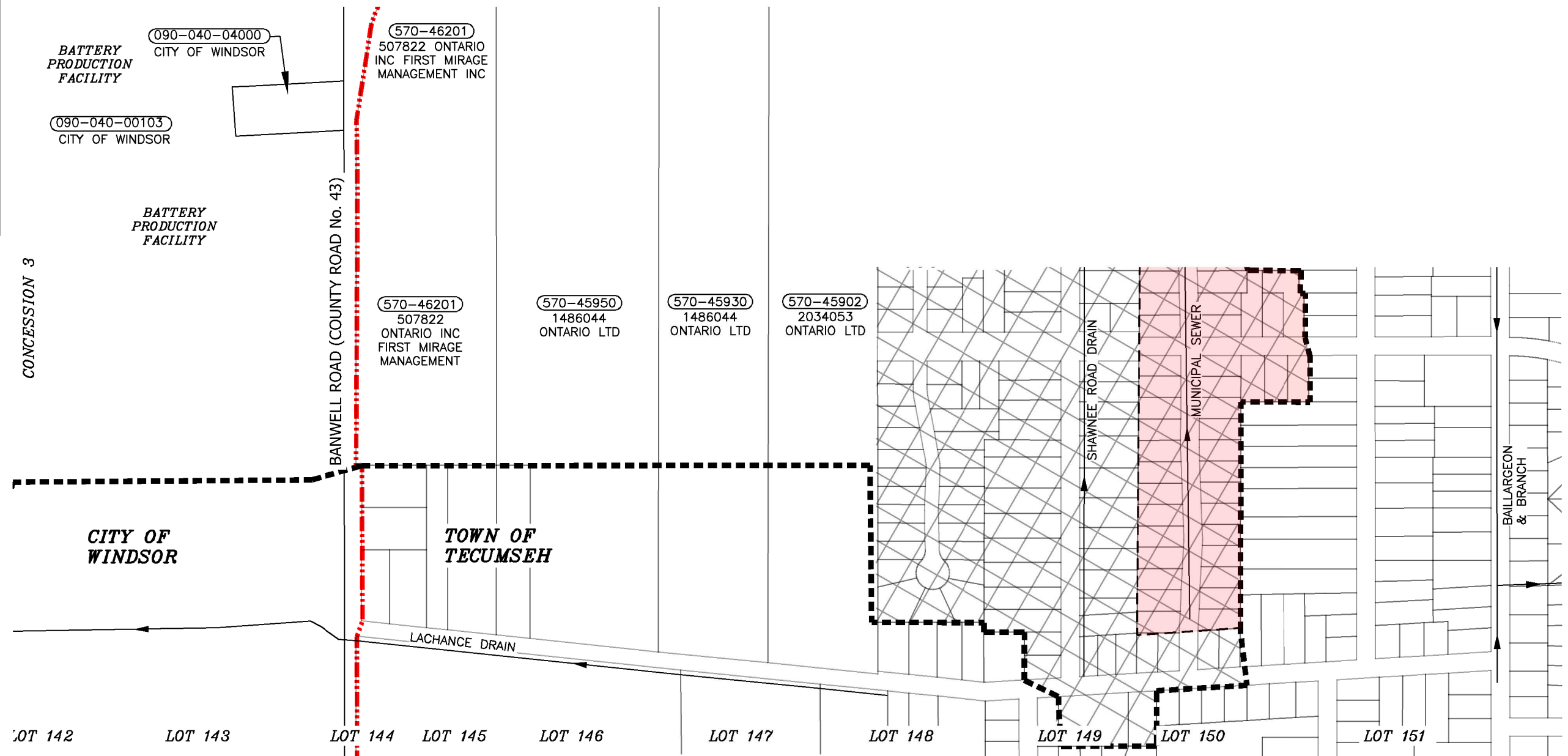

PLAN D
SCALE=1:5,000

Jan 20, 2023 - 10:04am C:\pwworking\directory\projects to 2017\330orm\0611685\176773-03-DRN-CON.dwg



Conditions of Use

Verify elevations and/or dimensions on drawing prior to use. Report any discrepancies to Dillon Consulting Limited.

Do not scale dimensions from drawing.

Do not modify drawing, re-use it, or use it for purposes other than those intended at the time of its preparation without prior written permission from Dillon Consulting Limited.

No.	ISSUED FOR	DATE	BY
3	FINAL REPORT SUBMISSION	20 JAN 23	MDH
2	PUBLIC INFORMATION CENTRE	25 MAR 22	MDH
1	CLIENT REVIEW	4 MAR 22	MDH

DESIGN	REVIEWED BY
MDH	CDP
DRAWN	CHECKED BY
KAW/OEM	TRO
DATE	
January 20, 2023	
SCALE	
AS SHOWN	



PROJECT NO. 17-6773

DRAWING SCALES BASED ON A 11" X 17" SHEET

'SCHEDULE G'

Drainage Report for the
GOUIN DRAIN
Town of Tecumseh & City of Windsor

SHEET TITLE: **PLAN D**

PAGE NO.: **4 of 21**

LEGEND

- GOUIN BRANCH DRAIN DRAINAGE AREA BOUNDARY
- GOUIN DRAIN
- OTHER DRAINS
- █ BLOCK 'B' ASSESSMENT
- █ BLOCK 'D' ASSESSMENT
- BRIDGE REPLACEMENT
- ⊕ FUTURE BRIDGE REPLACEMENT
- EXISTING BRIDGE
- ⊗ BRIDGE REMOVAL
- CB1 EXISTING CATCH BASIN
- CB1 NEW CATCH BASIN
- MH5 EXISTING MAINTENANCE HOLE
- ⊕ LOCAL BENCHMARK
- ⊕ S/P EXISTING SHED/POOL

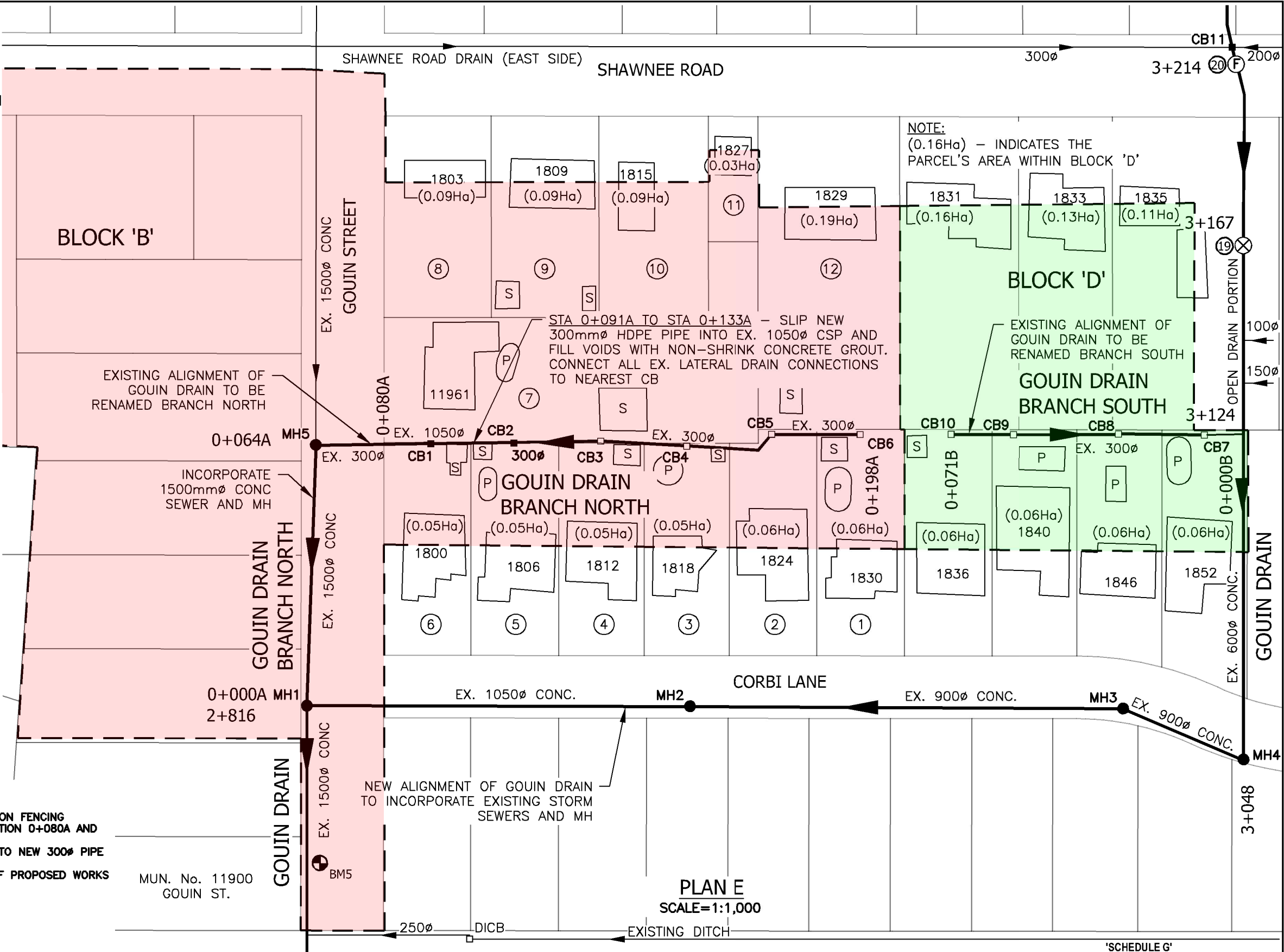

GOUIN DRAIN BRANCH NORTH		
#	ROLL No.	LANDOWNER
1	570-43250	ZORAN & MILICA STOJADINOVIC
2	570-43260	CATHERINE M. & ROSS A. DANBY
3	570-43270	DAVID T. GALLANT
4	570-43280	BRIAN & ELISA HOUSTON
5	570-43290	JOHN & SILVANA CRISPO
6	570-43295	TROY & LISA-MARIE MELOCHE
7	570-43300	GIUSEPPE VISELLI
8	570-43400	GILLES A. & LYNDA M. LACOMBE
9	570-43500	SCOTT R. LIEBROCK & ALEXIS R. SOVIE
10	570-43600	DWAIN & NANCY LARIVIERE
11	570-43700	ANDRE VISELLI
12	570-43800	JOANNE L. PEIRRE

- NOTES:**
- BENCHMARK INFORMATION ON SHEET 13
 - CONTRACTOR TO SUPPLY & INSTALL TEMPORARY CONSTRUCTION FENCING BETWEEN ALL HOMES AND WORKING CORRIDOR BETWEEN STATION 0+080A AND 0+133A
 - CONTRACTOR TO LOCATE AND CONNECT STORM DRAIN TILES TO NEW 300mm PIPE BETWEEN STA 0+079A AND STA 0+133A
 - REFER TO PROFILE 4 ON SHEET 9 FOR FURTHER DETAILS OF PROPOSED WORKS



Conditions of Use

Verify elevations and/or dimensions on drawing prior to use. Report any discrepancies to Dillon Consulting Limited.

Do not scale dimensions from drawing.

Do not modify drawing, re-use it, or use it for purposes other than those intended at the time of its preparation without prior written permission from Dillon Consulting Limited.

No.	ISSUED FOR	DATE	BY
3	FINAL REPORT SUBMISSION	20 JAN 23	MDH
2	PUBLIC INFORMATION CENTRE	25 MAR 22	MDH
1	CLIENT REVIEW	4 MAR 22	MDH

DESIGN	REVIEWED BY
MDH	CDP
DRAWN	CHECKED BY
OEM	TRO
DATE	January 20, 2023
SCALE	AS SHOWN

PROJECT NO. 17-6773

DRAWING SCALES BASED ON A 11" X 17" SHEET

'SCHEDULE G'

Drainage Report for the
GOUIN DRAIN
Town of Tecumseh & City of Windsor

SHEET TITLE: **PLAN E**

PAGE NO.: 5 of 21

Jan 20, 2023 - 10:04am C:\pwworking\directory\projects to 2017\330am\00611685\176773-03-DRN-COM.dwg

Jan 20, 2023 - 10:05am C:\pwworking\directory\projects to 2017\330am\d0611685\176773-03-PROF-DES-N.dwg

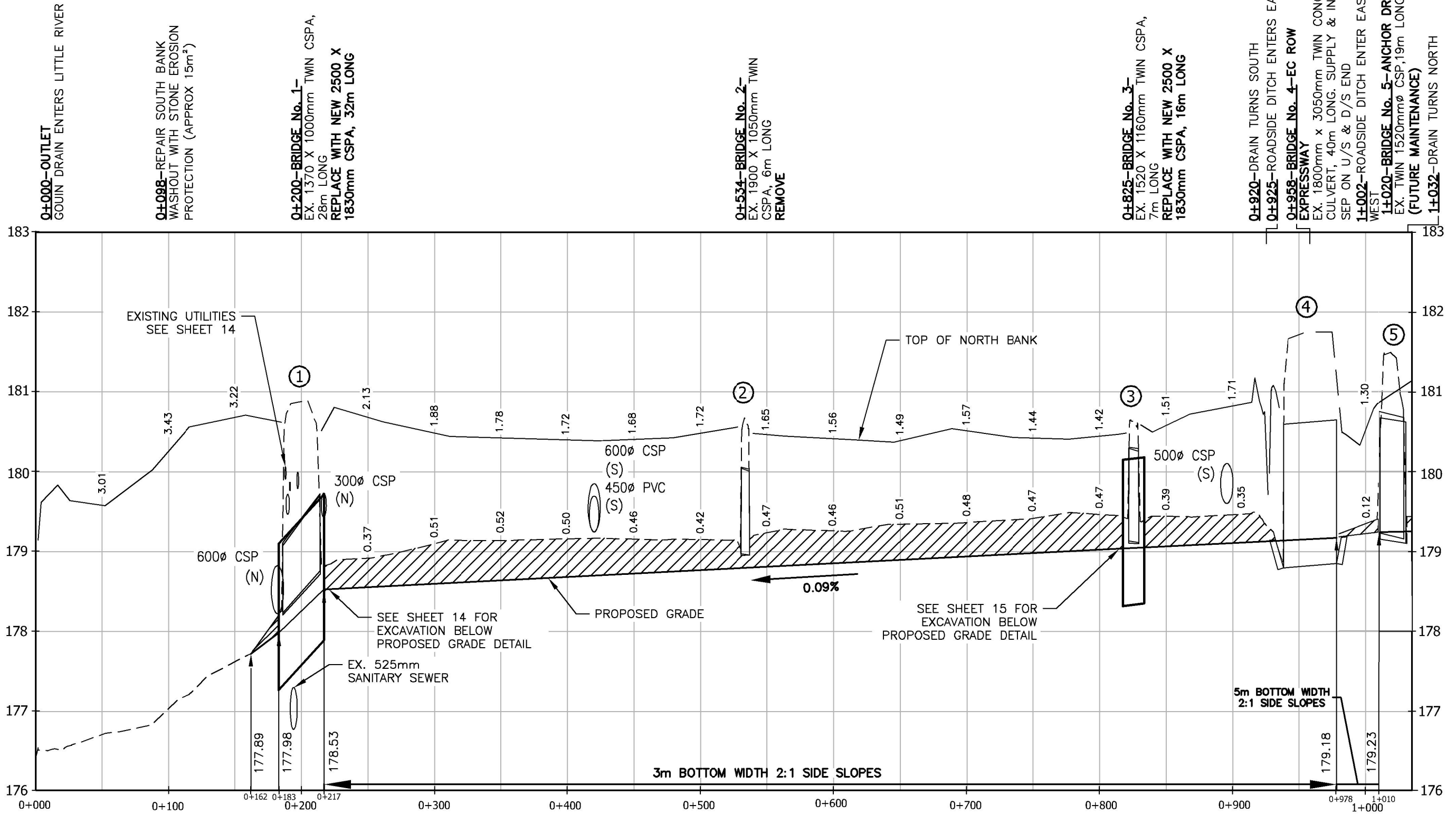

0+000-OUTLET
GOUIN DRAIN ENTERS LITTLE RIVER

0+098-REPAIR SOUTH BANK
WASHOUT WITH STONE EROSION PROTECTION (APPROX 15m²)

0+200-BRIDGE No. 1-
EX. 1370 X 1000mm TWIN CSPA, 28m LONG
REPLACE WITH NEW 2500 X 1830mm CSPA, 32m LONG

0+534-BRIDGE No. 2-
EX. 1900 X 1050mm TWIN CSPA, 6m LONG
REMOVE

0+825-BRIDGE No. 3-
EX. 1520 X 1160mm TWIN CSPA, 7m LONG
REPLACE WITH NEW 2500 X 1830mm CSPA, 16m LONG

0+920-DRAIN TURNS SOUTH
0+925-ROADSIDE DITCH ENTERS EAST
0+958-BRIDGE No. 4-EC ROW EXPRESSWAY
EX. 1800mm x 3050mm TWIN CONC BOX CULVERT, 40m LONG. SUPPLY & INSTALL SEP ON U/S & D/S END
1+002-ROADSIDE DITCH ENTER EAST & WEST
1+020-BRIDGE No. 5-ANCHOR DRIVE
EX. TWIN 1520mm CSP, 19m LONG
(FUTURE MAINTENANCE)
1+032-DRAIN TURNS NORTH

PROFILE 1
SCALE-HORIZ.=1: 3,000
VERT.=1: 100

SEE PROFILE 2



Conditions of Use

Verify elevations and/or dimensions on drawing prior to use. Report any discrepancies to Dillon Consulting Limited.

Do not scale dimensions from drawing.

Do not modify drawing, re-use it, or use it for purposes other than those intended at the time of its preparation without prior written permission from Dillon Consulting Limited.

No.	ISSUED FOR	DATE	BY
3	FINAL REPORT SUBMISSION	20 JAN 23	MDH
2	PUBLIC INFORMATION CENTRE	25 MAR 22	MDH
1	CLIENT REVIEW	4 MAR 22	MDH

DESIGN	MDH	REVIEWED BY	CDP
DRAWN	OEM	CHECKED BY	TRO
DATE	January 20, 2023		
SCALE	AS SHOWN		

DILLON CONSULTING

PROJECT NO. 17-6773

DRAWING SCALES BASED ON A 11" X 17" SHEET

'SCHEDULE G'

Drainage Report for the
GOUIN DRAIN
Town of Tecumseh & City of Windsor

SHEET TITLE
PROFILE STATION 0+000 TO STATION 1+010

PAGE NO.
6 of 21

Jan 20, 2023 - 10:05am C:\pwworking\directory\projects to 2017\336em\d0611685\176773-03-PROF-DES-COULN.dwg

SEE PROFILE 1

1+020-BRIDGE No. 5-ANCHOR DRIVE
EX. TWIN 1520mm \varnothing CSP, 19m LONG
(FUTURE MAINTENANCE)
1+032-DRAIN TURNS NORTH

1+104-SWALE FROM SOUTH
SUPPLY & INSTALL STONE EROSION PROTECTION (APPROX 10m²)
1+109-BRIDGE No. 6
EX. 2240 X 1630mm CSP, 7.6m LONG
(FUTURE MAINTENANCE)

1+191-BRIDGE No. 7
EX. 2440 X 1600mm CSP, 40.5m LONG
(FUTURE MAINTENANCE)

1+278-BRIDGE No. 8
EX. 2240 X 1630mm CSP, 9.7m LONG
REMOVE

1+376-SWALE FROM SOUTH
SUPPLY & INSTALL STONE EROSION PROTECTION (APPROX 15m²)

1+442 BRIDGE No. 9
EX. 2240 X 1630mm CSP, 8.2m LONG
REMOVE

1+549-SWALE FROM SOUTH
SUPPLY & INSTALL STONE EROSION PROTECTION (APPROX 10m²)

1+646-BRIDGE No. 10
EX. 2240 X 1630mm CSP, 7.8m LONG
REMOVE

1+751-SWALE FROM SOUTH
SUPPLY & INSTALL STONE EROSION PROTECTION (APPROX 10m²)

1+955-BRIDGE No. 11
EX. 2240 X 1630mm CSP, 7.9m LONG

1+980-BRIDGE No. 12
EX. 2240 X 1630mm CSP, 7.6m LONG

2+116-BRIDGE No. 13-BANWELL ROAD
EX. 2240 X 1630mm CSP, 15.6m LONG
(FUTURE MAINTENANCE)
2+124-SWALE FROM NORTH & SOUTH

SEE PROFILE 3

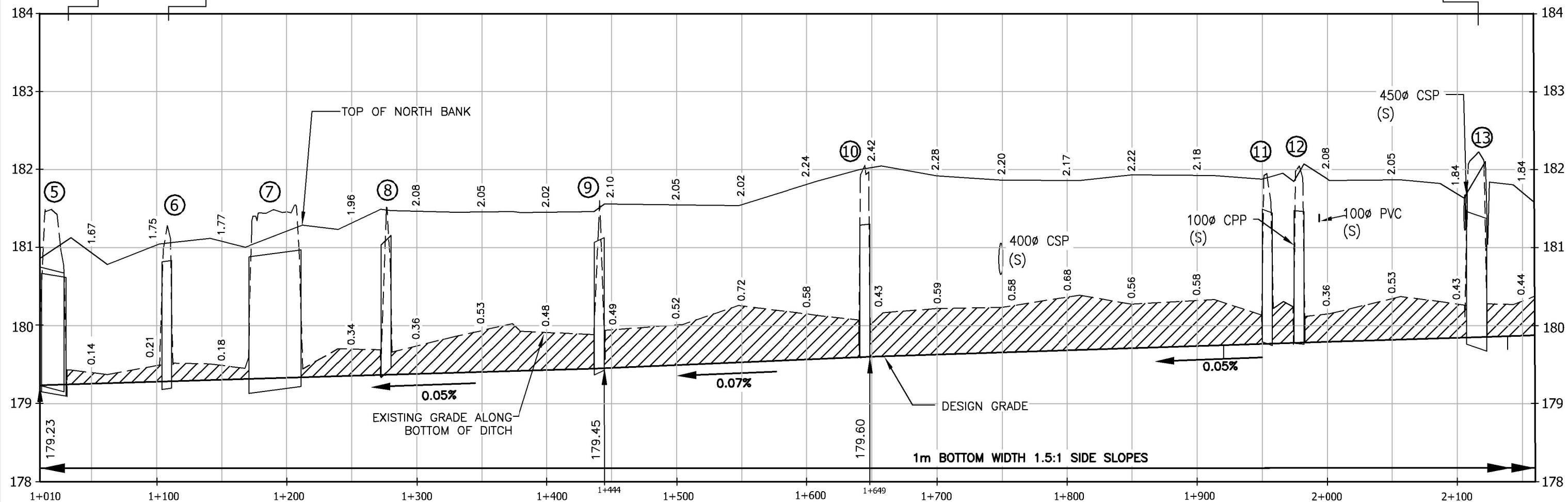

PROFILE 2
SCALE-HORIZ.=1:3,000
VERT.=1:100



Conditions of Use
Verify elevations and/or dimensions on drawing prior to use. Report any discrepancies to Dillon Consulting Limited.
Do not scale dimensions from drawing.
Do not modify drawing, re-use it, or use it for purposes other than those intended at the time of its preparation without prior written permission from Dillon Consulting Limited.

No.	ISSUED FOR	DATE	BY
3	FINAL REPORT SUBMISSION	18 JAN 23	MDH
2	PUBLIC INFORMATION CENTRE	25 MAR 22	MDH
1	CLIENT REVIEW	4 MAR 22	MDH

DESIGN	REVIEWED BY
MDH	CDP
DRAWN	CHECKED BY
KAW/OEM	TRO
DATE	
January :8, 2022	
SCALE	
AS SHOWN	

DILLON CONSULTING

PROJECT NO. 17-6773

DRAWING SCALES BASED ON A 11" X 17" SHEET

'SCHEDULE G'

Drainage Report for the
GOUIN DRAIN
Town of Tecumseh & City of Windsor

SHEET TITLE
PROFILE STATION 1+010 TO STATION 2+160

PAGE NO.
7 of 21

Jan 20, 2023 - 10:06am C:\pwworking\directory\projects to 2017\330am\0611685\176773-03-PROF-DES-GOUJN.dwg

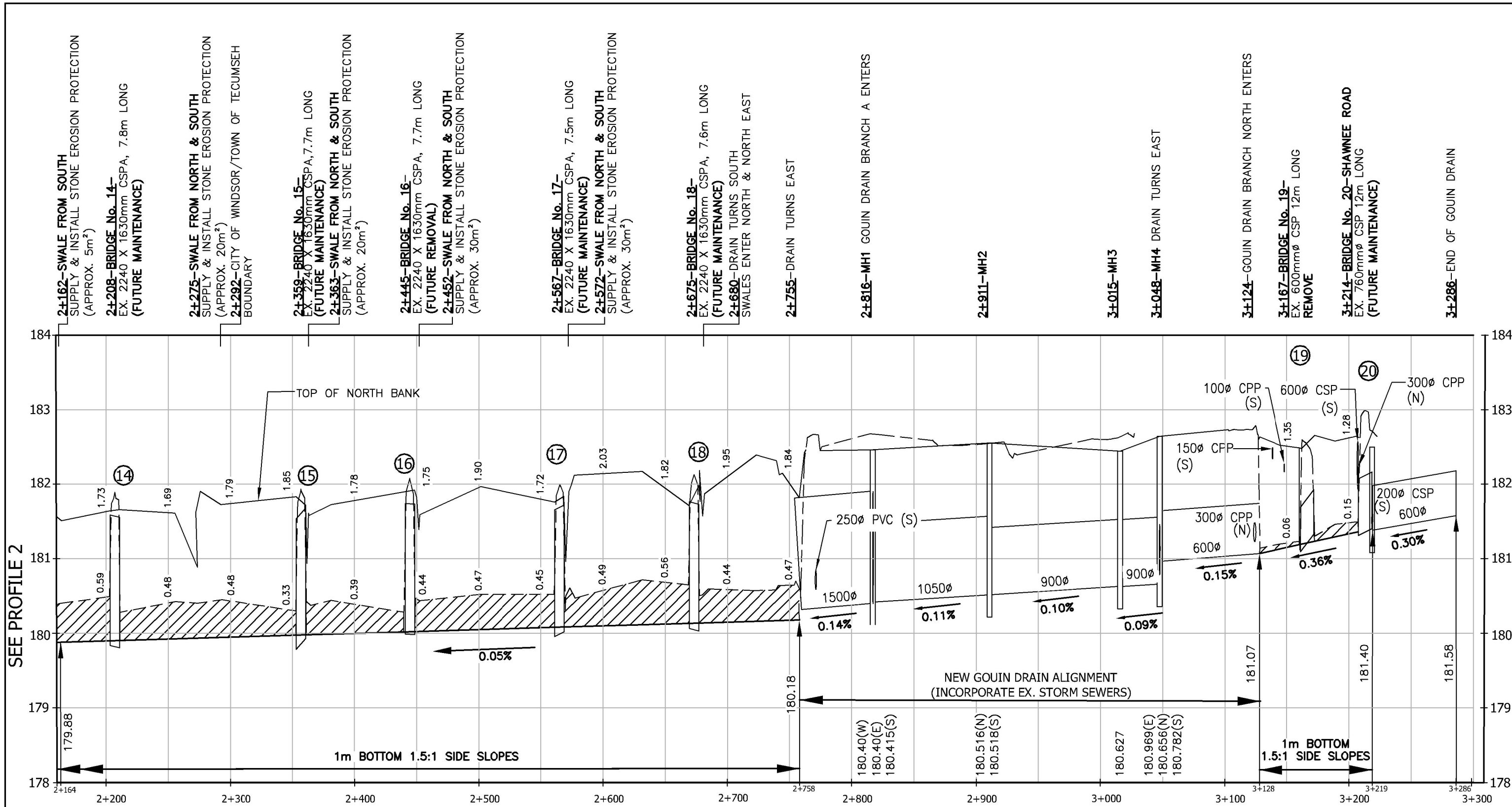

SEE PROFILE 2

PROFILE 3
SCALE-HORIZ.=1:3,000
VERT.=1:100



Conditions of Use
Verify elevations and/or dimensions on drawing prior to use. Report any discrepancies to Dillon Consulting Limited.
Do not scale dimensions from drawing.
Do not modify drawing, re-use it, or use it for purposes other than those intended at the time of its preparation without prior written permission from Dillon Consulting Limited.

No.	ISSUED FOR	DATE	BY
3	FINAL REPORT SUBMISSION	18 JAN 23	MDH
2	PUBLIC INFORMATION CENTRE	25 MAR 22	MDH
1	CLIENT REVIEW	4 MAR 22	MDH

DESIGN	REVIEWED BY
MDH	CDP
DRAWN	CHECKED BY
KAW/OEM	TRO
DATE	
January :8, 2022	
SCALE	
AS SHOWN	

DILLON CONSULTING

PROJECT NO. 17-6773

DRAWING SCALES BASED ON A 11" X 17" SHEET

'SCHEDULE G'

Drainage Report for the
GOUIN DRAIN
Town of Tecumseh & City of Windsor

SHEET TITLE
PROFILE STATION 2+160 TO STATION 3+286

PAGE NO.
8 of 21

Jan 20, 2023 - 10:06am C:\pwworking\directory\projects to 2017\330am\d0611685\176773-03-PROF-DES-GOUIN.dwg

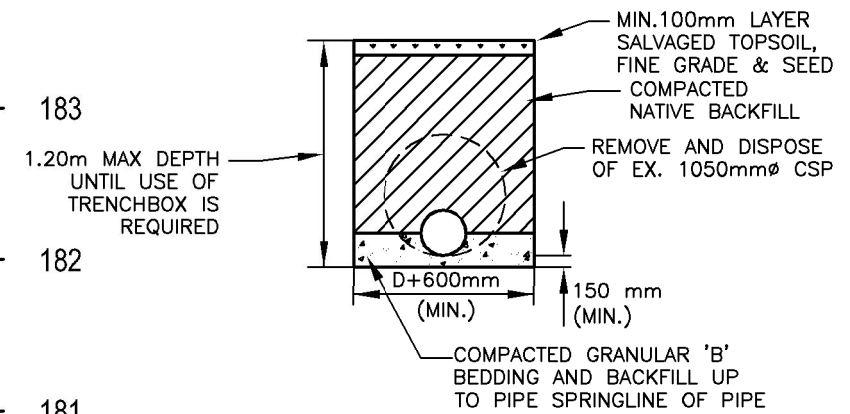
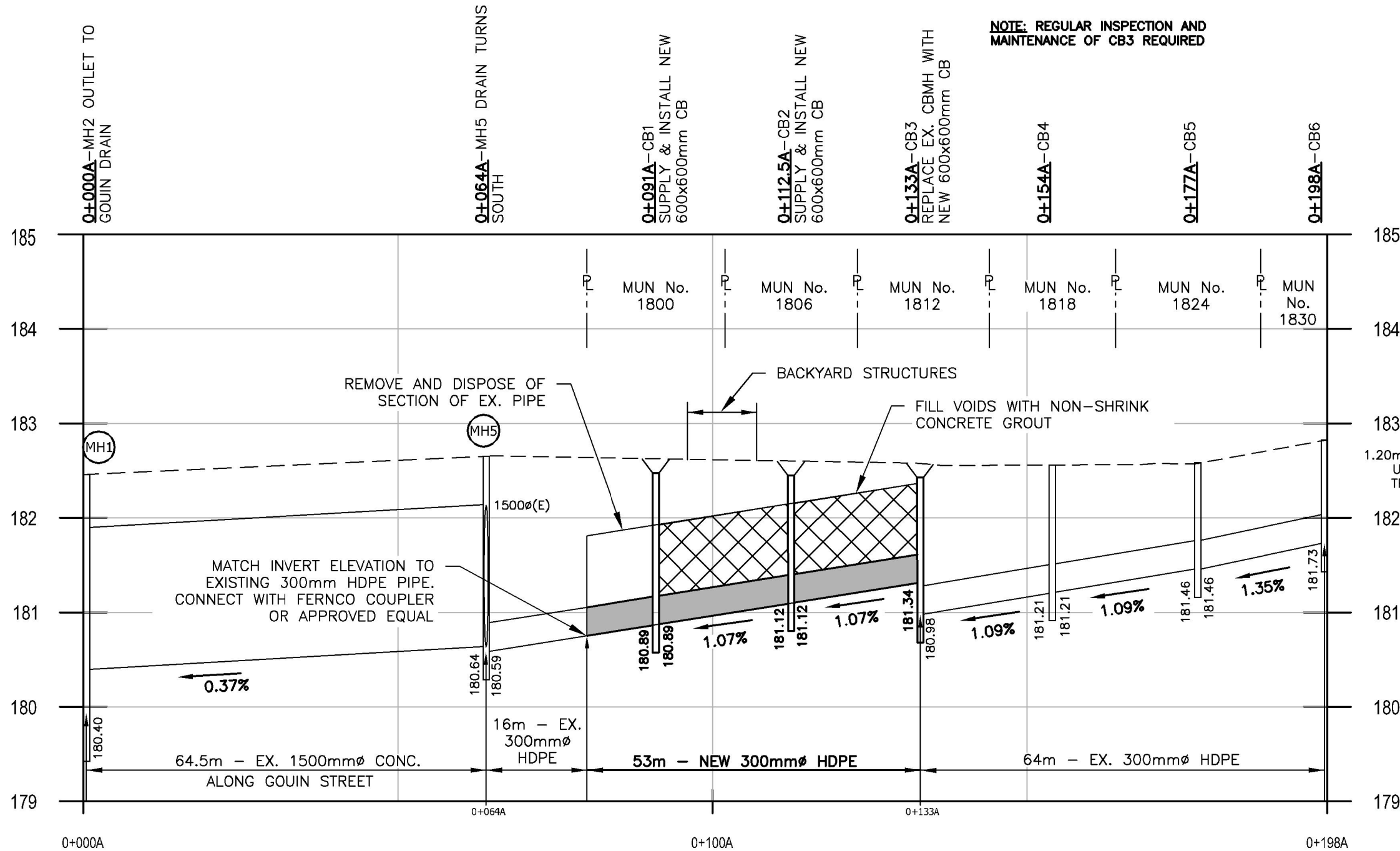

**GOUIN DRAIN BRANCH NORTH
REPLACEMENT DETAIL**
SCALE - NTS

PROFILE 4 - GOUIN DRAIN BRANCH NORTH
SCALE-HORIZ.=1:750
VERT.=1:50

CATCH BASIN No.	SIZE (mm)	STATION	TOP ELEVATION (m)	INVERT ELEVATION (m)	
				INLETS	OUTLETS
CB1	600x600	0+091A	182.48	S. INV 180.89 (300ø)	N. INV 180.89 (300ø)
CB2	600x600	0+112.5A	182.45	S. INV 180.12 (300ø)	N. INV 180.12 (300ø)
CB3	600x600	0+133A	182.43	S. INV 180.98 (300ø)	N. INV 181.34 (300ø)

NOTE: TOP ELEVATION OF CATCH BASINS ARE TO BE APPROXIMATELY 0.15m BELOW EXISTING GRADE



Conditions of Use
Verify elevations and/or dimensions on drawing prior to use. Report any discrepancies to Dillon Consulting Limited.
Do not scale dimensions from drawing.
Do not modify drawing, re-use it, or use it for purposes other than those intended at the time of its preparation without prior written permission from Dillon Consulting Limited.

No.	ISSUED FOR	DATE	BY
3	FINAL REPORT SUBMISSION	18 JAN 23	MDH
2	PUBLIC INFORMATION CENTRE	25 MAR 22	MDH
1	CLIENT REVIEW	4 MAR 22	MDH

DESIGN	REVIEWED BY
MDH	CDP
DRAWN	CHECKED BY
OEM	TRO
DATE	January :8, 2022
SCALE	AS SHOWN

PROJECT NO: 17-6773
DRAWING SCALES BASED ON A 11" X 17" SHEET

'SCHEDULE G'
Drainage Report for the
GOUIN DRAIN
Town of Tecumseh & City of Windsor

SHEET TITLE: **PROFILE GOUIN DRAIN BRANCH NORTH**
PAGE NO.: 9 of 21

Jan 20, 2023 - 10:06am C:\pwworking\directory\projects to 2017\336am\d0611685\176773-03-PROF-DES-GOUIN.dwg

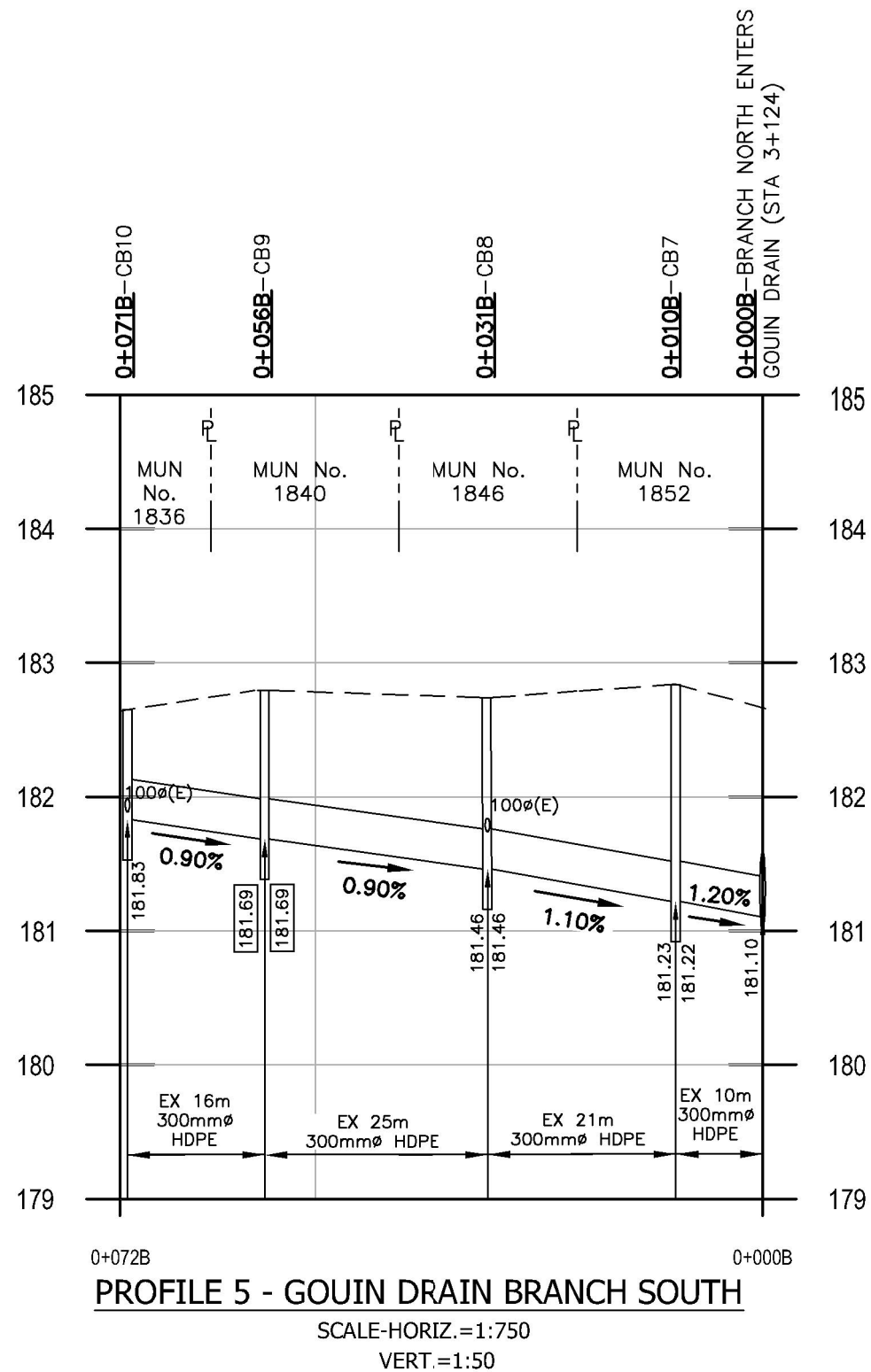

181.69 - TEXT BOX INDICATES ELEVATION IS ASSUMED AND NOT SURVEYED



Conditions of Use
 Verify elevations and/or dimensions on drawing prior to use. Report any discrepancies to Dillon Consulting Limited.
 Do not scale dimensions from drawing.
 Do not modify drawing, re-use it, or use it for purposes other than those intended at the time of its preparation without prior written permission from Dillon Consulting Limited.

No.	ISSUED FOR	DATE	BY
3	FINAL REPORT SUBMISSION	18 JAN 23	MDH
2	PUBLIC INFORMATION CENTRE	25 MAR 22	MDH
1	CLIENT REVIEW	4 MAR 22	MDH

DESIGN	REVIEWED BY
MDH	CDP
DRAWN	CHECKED BY
OEM	TRO
DATE	
January :8, 2022	
SCALE	
AS SHOWN	

PROJECT NO. 17-6773
 DRAWING SCALES BASED ON A 11" X 17" SHEET

'SCHEDULE G'
 Drainage Report for the
GOUIN DRAIN
 Town of Tecumseh & City of Windsor

SHEET TITLE
PROFILE GOUIN DRAIN BRANCH SOUTH & BRANCH DRAIN DETAILS

PAGE NO.
 10 of 21

Jan 20, 2023 - 10:07 am C:\pwworking\directory\projects to 2017\336am\d0611685\176773-03-PROF-DES-N.dwg

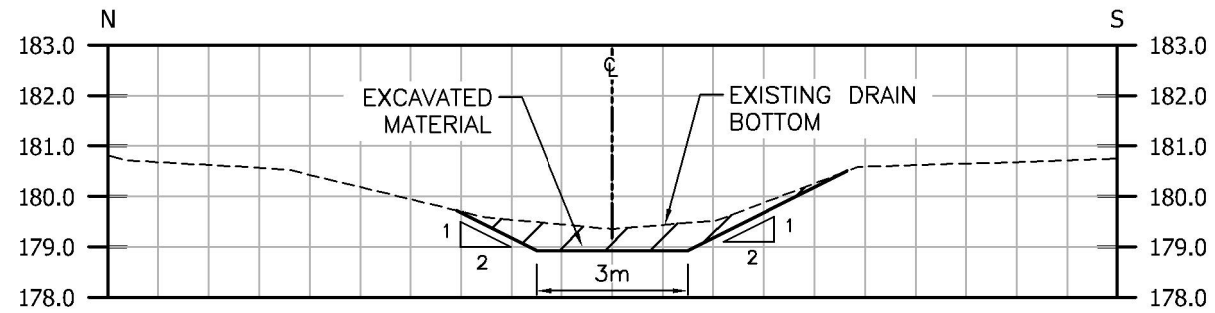

CROSS-SECTION 0+690 (LOOKING UPSTREAM)
SCALE-1:150

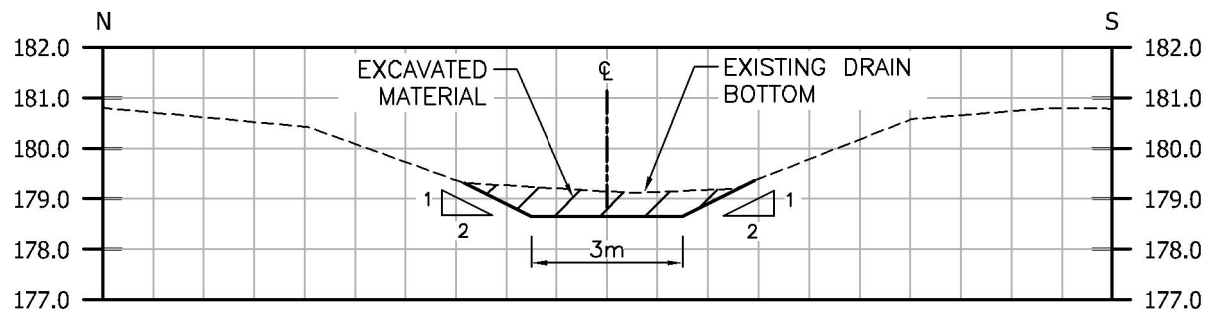

CROSS-SECTION 0+365 (LOOKING UPSTREAM)
SCALE-1:150

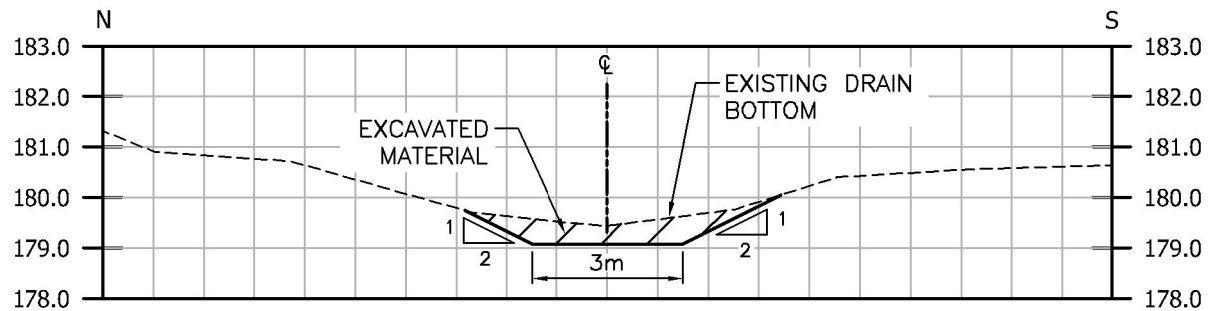

CROSS-SECTION 0+867 (LOOKING UPSTREAM)
SCALE-1:150



Conditions of Use

Verify elevations and/or dimensions on drawing prior to use. Report any discrepancies to Dillon Consulting Limited.
Do not scale dimensions from drawing.
Do not modify drawing, re-use it, or use it for purposes other than those intended at the time of its preparation without prior written permission from Dillon Consulting Limited.

No.	ISSUED FOR	DATE	BY
3	FINAL REPORT SUBMISSION	20 JAN 23	MDH
2	PUBLIC INFORMATION CENTRE	25 MAR 22	MDH
1	CLIENT REVIEW	4 MAR 22	MDH

DESIGN	MDH	REVIEWED BY	CDP
DRAWN	OEM	CHECKED BY	TRO
DATE	January 20, 2023		
SCALE	AS SHOWN		

PROJECT NO. 17-6773
DRAWING SCALES BASED ON A 11" X 17" SHEET

'SCHEDULE G'
Drainage Report for the
GOUIN DRAIN
Town of Tecumseh & City of Windsor

CROSS SECTIONS STATION 0+000 TO STATION 1+010

PAGE NO. 11 of 21

Jan 20, 2023 - 10:07 am C:\pwworking\directory\projects to 2017\336am\d0611685\176773-03-PROF-DES-GOUIN.dwg

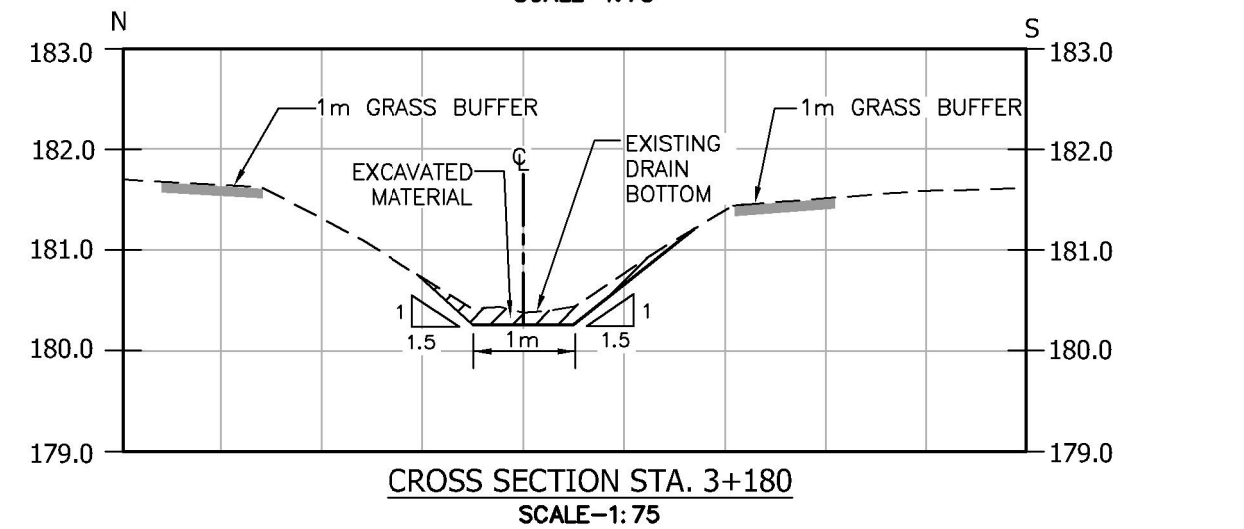
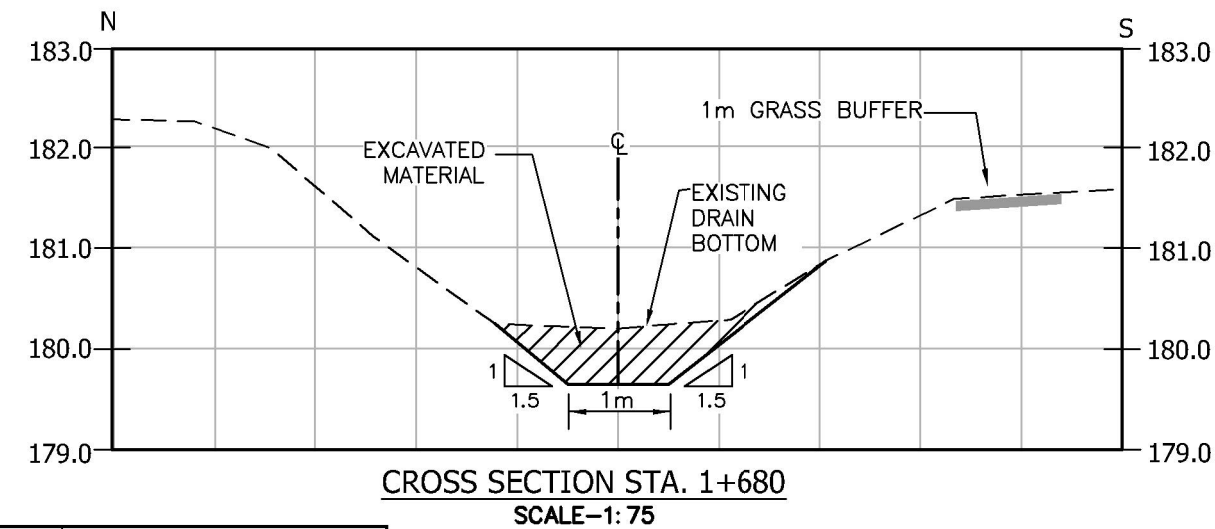
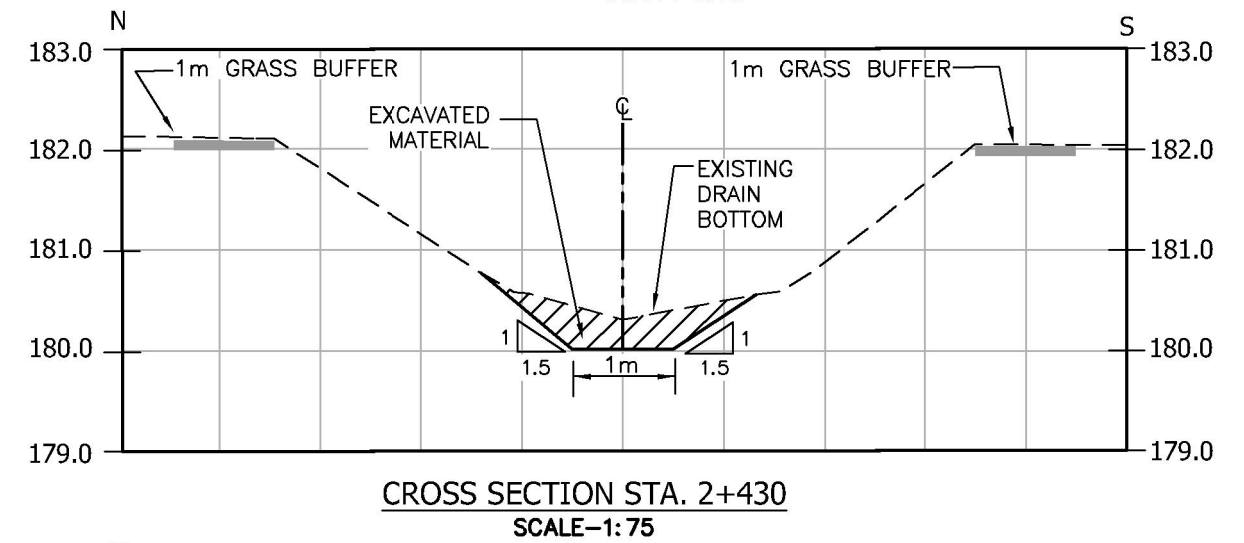
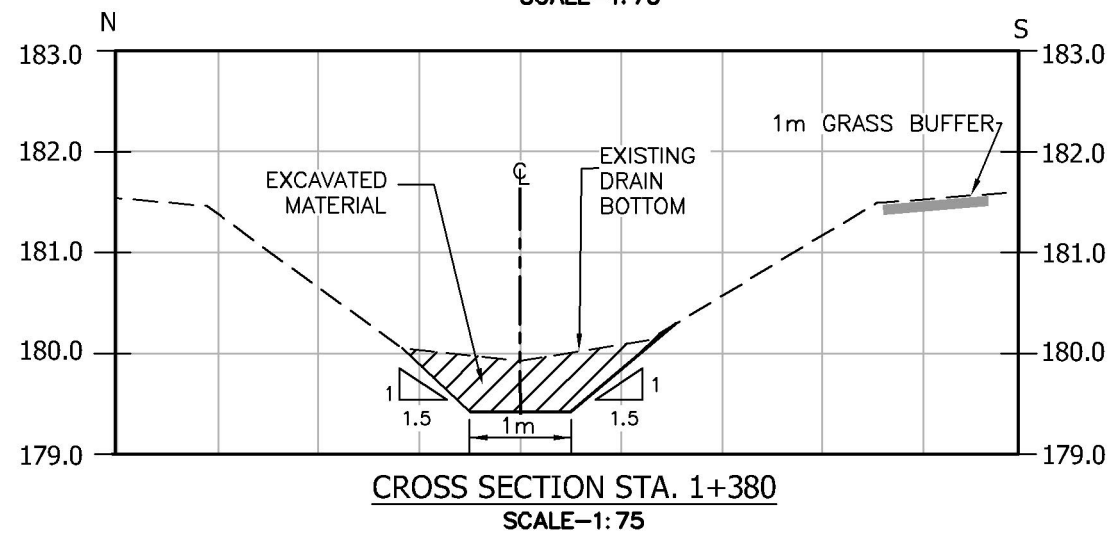
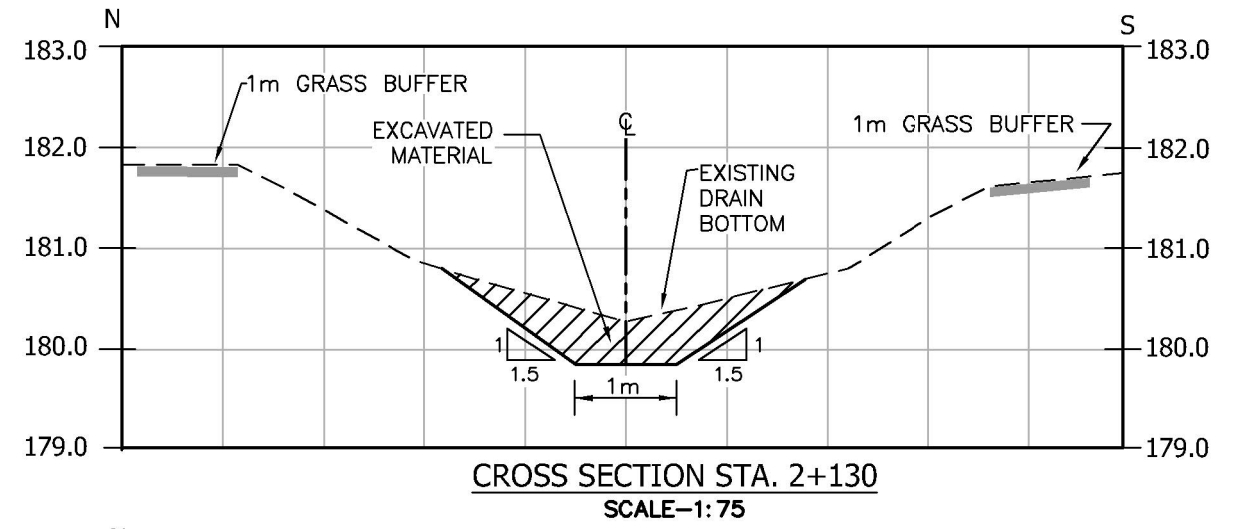
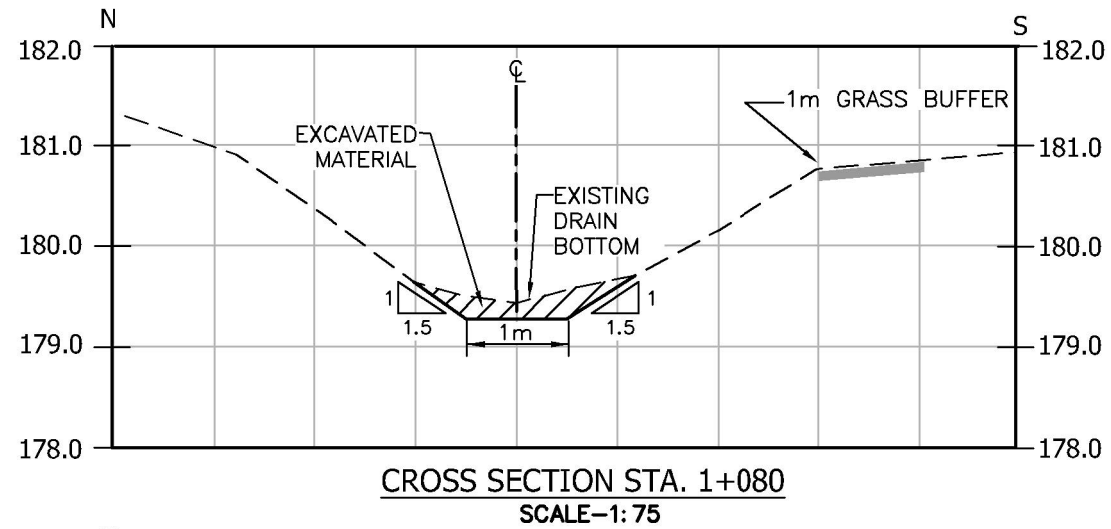

Conditions of Use

Verify elevations and/or dimensions on drawing prior to use. Report any discrepancies to Dillon Consulting Limited.
Do not scale dimensions from drawing.
Do not modify drawing, re-use it, or use it for purposes other than those intended at the time of its preparation without prior written permission from Dillon Consulting Limited.

No.	ISSUED FOR	DATE	BY
3	FINAL REPORT SUBMISSION	18 JAN 23	MDH
2	PUBLIC INFORMATION CENTRE	25 MAR 22	MDH
1	CLIENT REVIEW	4 MAR 22	MDH

DESIGN	REVIEWED BY
MDH	CDP
DRAWN	CHECKED BY
KAW/OEM	TRO
DATE	
January :8, 2022	
SCALE	
AS SHOWN	

PROJECT NO. 17-6773
DRAWING SCALES BASED ON A 11" X 17" SHEET

'SCHEDULE G'
Drainage Report for the
GOUIN DRAIN
Town of Tecumseh & City of Windsor

SHEET TITLE
CROSS SECTIONS STATION 1+010 TO STATION 3+286

PAGE NO.
12 of 21

Jan 20, 2023 - 10:07 am C:\pwworking\directory\projects to 2017\336am\0611685\176773-03-PROF-DES-GOUIN.dwg

TABLE 2 - ACCESS BRIDGE DESIGN INFORMATION	BRIDGE REPLACEMENTS		FUTURE BRIDGE REPLACEMENTS								
	BRIDGE No. 1	BRIDGE No. 3	BRIDGE No. 5	BRIDGE No. 6	BRIDGE No. 7	BRIDGE No. 13	BRIDGE No. 14	BRIDGE No. 15	BRIDGE No. 17	BRIDGE No. 18	BRIDGE No. 20
BRIDGE ϕ LOCATION (STA.)	0+200	0+825	1+020	1+109	1+191	2+116	2+208	2+359	2+567	2+675	3+214
BRIDGE TYPE	UTILITY	UTILITY	ROAD	FARM	DRIVEWAY	ROAD	FARM	FARM	FARM	FARM	ROAD
PIPE INVERT ELEV. U/S SIDE(m)	177.89	178.35	179.06	179.12	179.16	179.69	179.72	179.74	179.91	179.97	181.38
PIPE INVERT ELEV. D/S SIDE(m)	177.28	178.33	179.04	179.11	179.11	179.67	179.70	179.73	179.90	179.95	181.31
TOP OF ϕ DRIVEWAY SURFACE ELEV. (m)	180.88	180.64	181.57	181.28	181.49	182.23	181.90	181.94	182.01	182.13	182.99
DRAIN BOTTOM (m) (DESIGN) (AT CENTRELINE OF CULVERT)	178.25	179.05	179.25	179.29	179.33	179.86	179.90	179.98	180.08	180.14	181.34
MIN. TOP WIDTH OF DRIVEWAY (m)	24.0	7.3	8.5	7.3	22.0	12.0	7.3	7.3	7.3	7.3	6.0
MIN. CULVERT GRADE (%)	1.90%	0.10%	0.10%	0.10%	0.10%	0.10%	0.10%	0.10%	0.10%	0.10%	0.10%
CULVERT TYPE	CSPA	CSPA	65-D	CSPA	CSPA	CSPA	CSPA	CSPA	CSPA	CSPA	CSP
CULVERT MATERIAL	ALUM.	ALUM.	CONCRETE	ALUM.	ALUM.	POLY-LAM.	ALUM.	ALUM.	ALUM.	ALUM.	POLY-LAM.
CULVERT LENGTH (m)	32	16	18	14	41	18	16	16	16	16	12
CULVERT THICKNESS (mm)	3.5	3.5	-	3.5	3.5	3.5	3.5	3.5	3.5	3.5	2.8
CULVERT CORRUGATIONS (mm)	125x25	125x25	-	125X25	125X25	125x25	125x25	125x25	125x25	125x25	68x13
PIPE SIZE (mm)	2500x1830	2500x1830	TWIN 1500	2230x1700	2230x1700	2500x1830	2230X1700	2230X1700	2230X1700	2230X1700	750
CULVERT ENDWALL TYPE	SLOPING	SLOPING	BLOCK	SLOPING	SLOPING	BLOCK	SLOPING	SLOPING	SLOPING	SLOPING	SLOPING
TOP OF BLOCK WALL ELEV. (m)	-	-	181.30	-	-	182.00	-	-	-	-	-
NUMBER OF BLOCK ROWS HIGH	-	-	4	-	-	4	-	-	-	-	-

SITE BENCHMARKS

- BM1 – TOP OF NUT OF FIRE HYDRANT LOCATED SOUTH OF LAUZON ROAD CUL-DE-SAC AT APPROX. STA. 0+196.
ELEVATION=181.34m
- BM2 – SOUTH EAST CORNER OF CONCRETE PAD OF ELECTRICAL SWITCHING UNIT AT APPROX. STA. 0+817.
ELEVATION=180.87m
- BM3 – TOP OF SOUTH END OF CONCRETE BOX CULVERT UNDER EC ROW EXPRESSWAY AT APPROX. STA. 0+980.
ELEVATION=181.18m
- BM4 – RIM ELEVATION OF MAINTENANCE HOLE LOCATED EAST OF BANWELL ROAD & SOUTH OF DRAIN AT APPROX. STA. 2+131.
ELEVATION=182.88m
- BM5 – PKNAIL IN TOP OF CONCRETE CURB ON NORTH SIDE OF GOUIN STREET ON THE PRODUCTION SOUTHERLY OF THE EAST SIDE OF DWELLING LOCATED AT MUN. NO. 11900 GOUIN STREET
ELEVATION=182.50m

NOTE: CONTRACTOR TO VERIFY BENCHMARKS PRIOR TO CONSTRUCTION.

CONTRACTOR IS RESPONSIBLE FOR ARRANGING UTILITY LOCATES PRIOR TO CONSTRUCTION



Conditions of Use

Verify elevations and/or dimensions on drawing prior to use. Report any discrepancies to Dillon Consulting Limited.

Do not scale dimensions from drawing.

Do not modify drawing, re-use it, or use it for purposes other than those intended at the time of its preparation without prior written permission from Dillon Consulting Limited.

No.	ISSUED FOR	DATE	BY
3	FINAL REPORT SUBMISSION	18 JAN 23	MDH
2	PUBLIC INFORMATION CENTRE	25 MAR 22	MDH
1	CLIENT REVIEW	4 MAR 22	MDH

DESIGN	REVIEWED BY
MDH	CDP
DRAWN	CHECKED BY
KAW/OEM	TRO
DATE	January :8, 2022
SCALE	AS SHOWN

PROJECT NO. 17-6773

DRAWING SCALES BASED ON A 11" X 17" SHEET

Drainage Report for the
GOUIN DRAIN
Town of Tecumseh & City of Windsor

SHEET TITLE
BRIDGE DESIGN INFORMATION

PAGE NO. 13 of 21

Jan 20, 2023 - 10:08am C:\pwworking\directory\projects to 2017\336am\d0611685\176773-03-PROF-DES-GOUJN.dwg

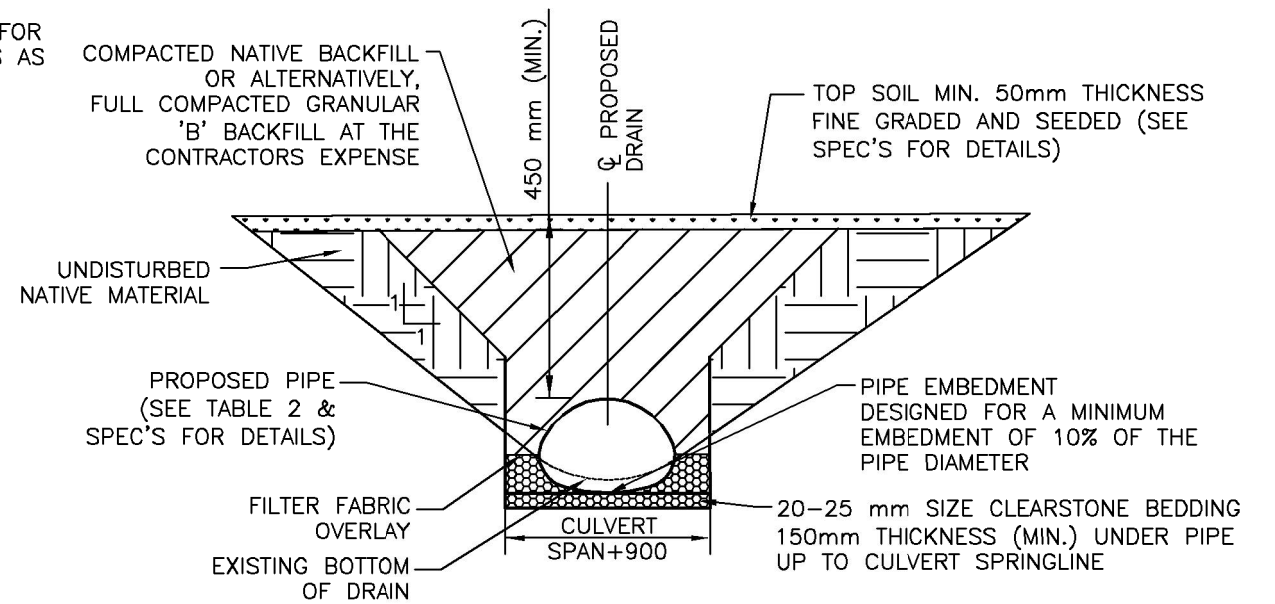
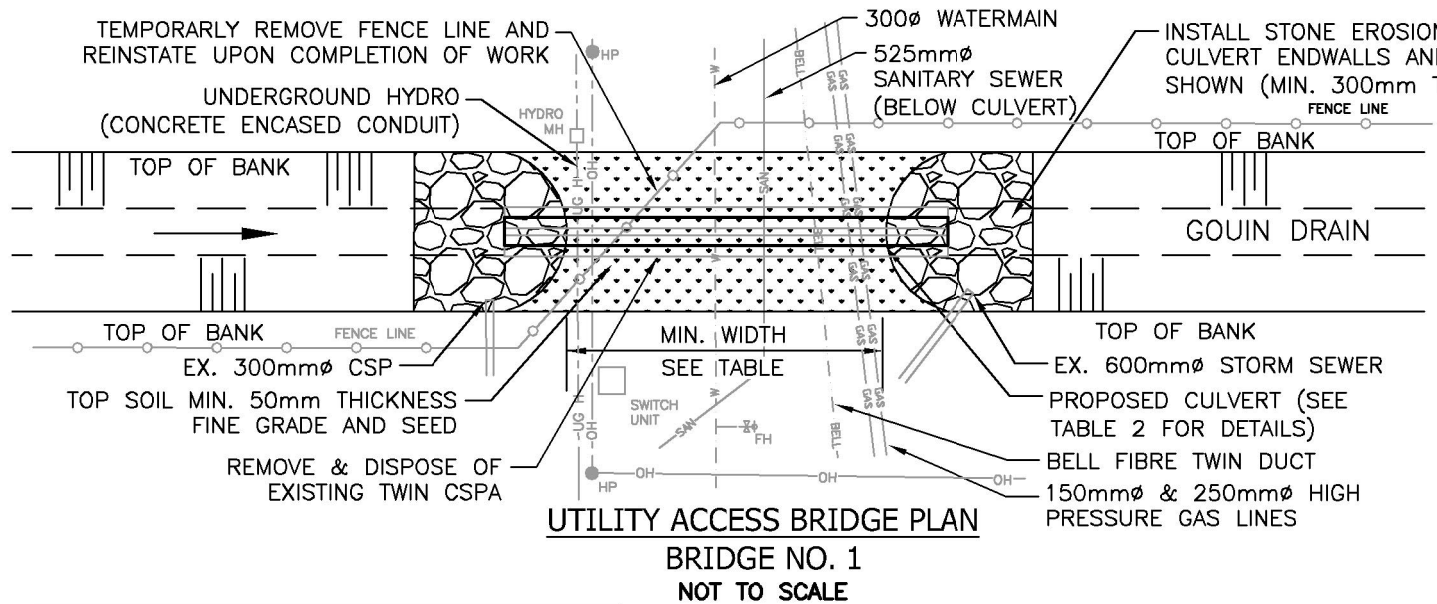

NOTE:

- LOCATION OF UTILITIES IS APPROXIMATE. CONTRACTOR MUST ACQUIRE UTILITY LOCATES PRIOR TO WORK AND NOTIFY RESPECTIVE UTILITY COMPANY. CONTRACTOR IS RESPONSIBLE FOR PROTECTING ALL UTILITIES TO THE SATISFACTION OF THE RESPECTIVE UTILITY OWNER FOR THE DURATION OF CONSTRUCTION.
- UTILITY SUPPORT PLAN FOR THE CONCRETE ENCASED HYDRO CONDUIT REQUIRED TO BE SEALED BY A PROFESSIONAL ENGINEER LICENSED IN THE PROVINCE OF ONTARIO

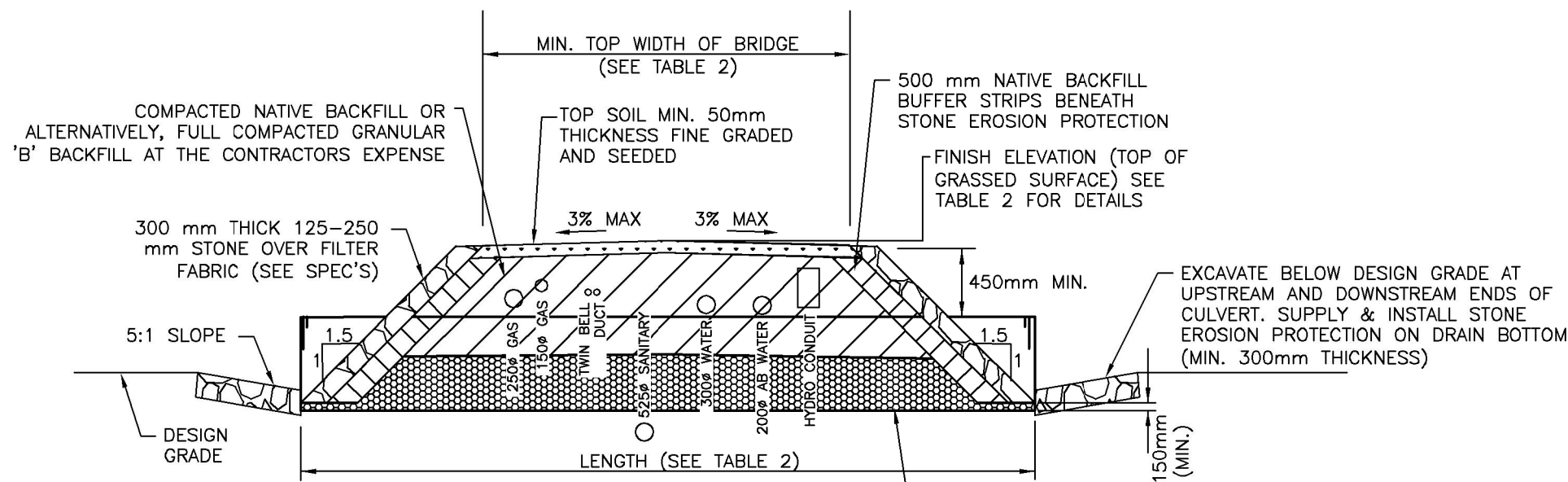

APPROXIMATE DEPTH OF UTILITIES:
 250Ø GAS: 1.0m
 150Ø GAS: 0.8m
 TWIN BELL DUCT: 0.9m
 525Ø SANITARY: 3.5m
 300Ø WATER: 1.0m
 0.6mWx0.8mH HYDRO CONDUIT: UNKNOWN
 200Ø ABANDONED WATER: UNKNOWN



Conditions of Use

Verify elevations and/or dimensions on drawing prior to use. Report any discrepancies to Dillon Consulting Limited.

Do not scale dimensions from drawing.

Do not modify drawing, re-use it, or use it for purposes other than those intended at the time of its preparation without prior written permission from Dillon Consulting Limited.

No.	ISSUED FOR	DATE	BY
3	FINAL REPORT SUBMISSION	18 JAN 23	MDH
2	PUBLIC INFORMATION CENTRE	25 MAR 22	MDH
1	CLIENT REVIEW	4 MAR 22	MDH

DESIGN	REVIEWED BY
MDH	CDP
DRAWN	CHECKED BY
OEM	TRO
DATE	January :8, 2022
SCALE	AS SHOWN

DILLON CONSULTING

PROJECT NO. 17-6773

DRAWING SCALES BASED ON A 11" X 17" SHEET

'SCHEDULE G'

Drainage Report for the
GOUIN DRAIN
 Town of Tecumseh & City of Windsor

SHEET TITLE
BRIDGE No. 1 REPLACEMENT

PAGE NO.
 14 of 21

Jan 20, 2023 - 10:08am C:\pwworking\directory\projects to 2017\336am\d0611685\176773-03-PROF-DES-GOUIN.dwg

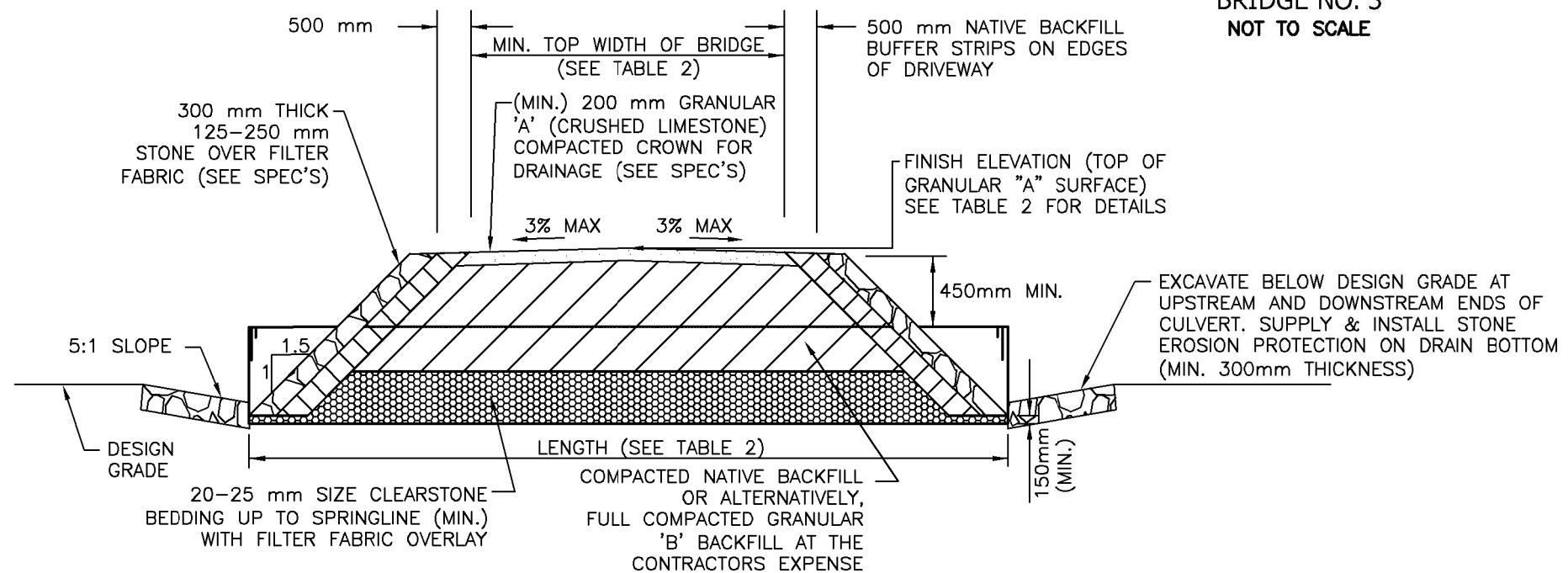
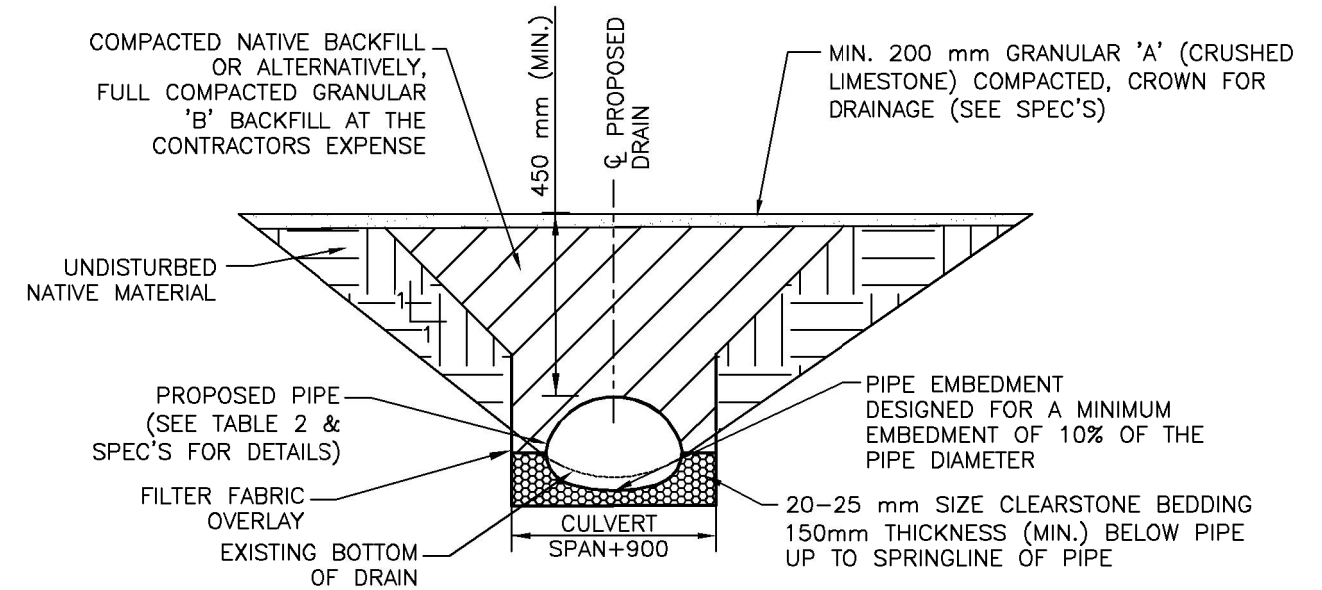
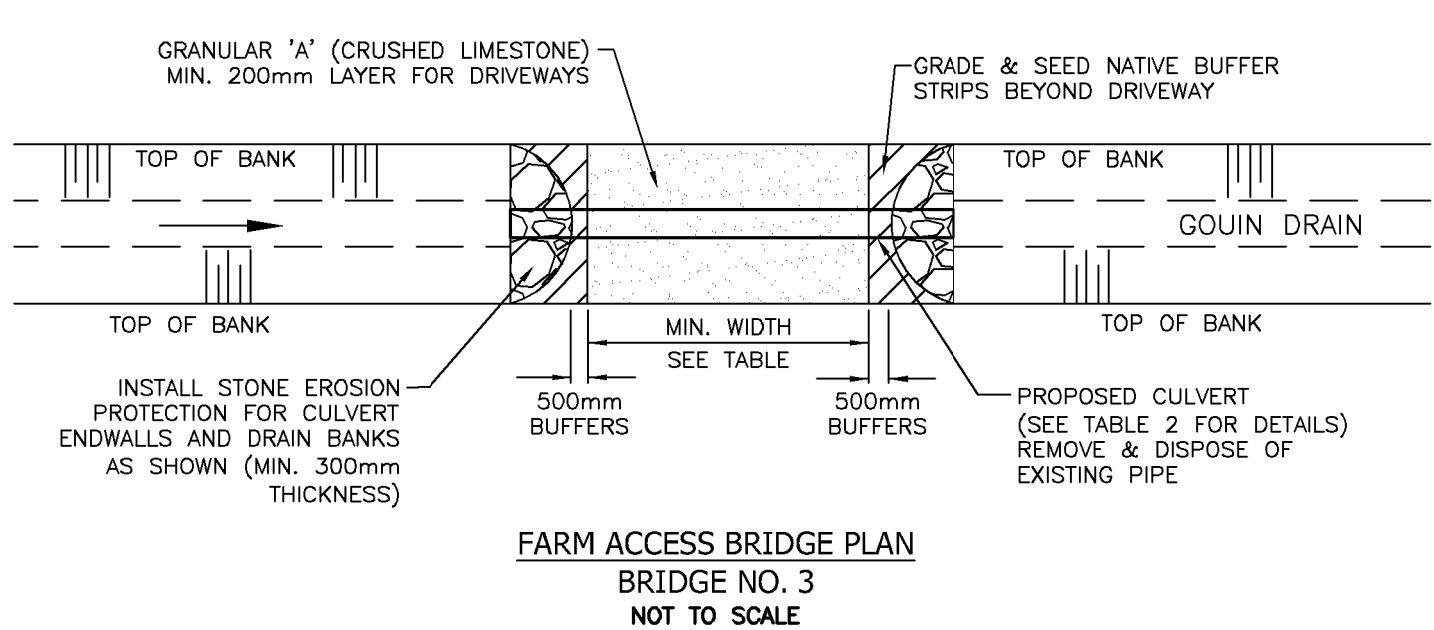

FARM ACCESS BRIDGE LONGITUDINAL SECTION
BRIDGE NO. 3
NOT TO SCALE



Conditions of Use

Verify elevations and/or dimensions on drawing prior to use. Report any discrepancies to Dillon Consulting Limited.
Do not scale dimensions from drawing.
Do not modify drawing, re-use it, or use it for purposes other than those intended at the time of its preparation without prior written permission from Dillon Consulting Limited.

No.	ISSUED FOR	DATE	BY
3	FINAL REPORT SUBMISSION	18 JAN 23	MDH
2	PUBLIC INFORMATION CENTRE	25 MAR 22	MDH
1	CLIENT REVIEW	4 MAR 22	MDH

DESIGN	REVIEWED BY
MDH	CDP
DRAWN	CHECKED BY
OEM	TRO
DATE	January :8, 2022
SCALE	AS SHOWN

	PROJECT NO.	17-6773
	DRAWING SCALES BASED ON A 11" X 17" SHEET	

'SCHEDULE G'	
Drainage Report for the GOUIN DRAIN Town of Tecumseh & City of Windsor	
SHEET TITLE	BRIDGE No. 3 REPLACEMENT
PAGE NO.	15 of 21

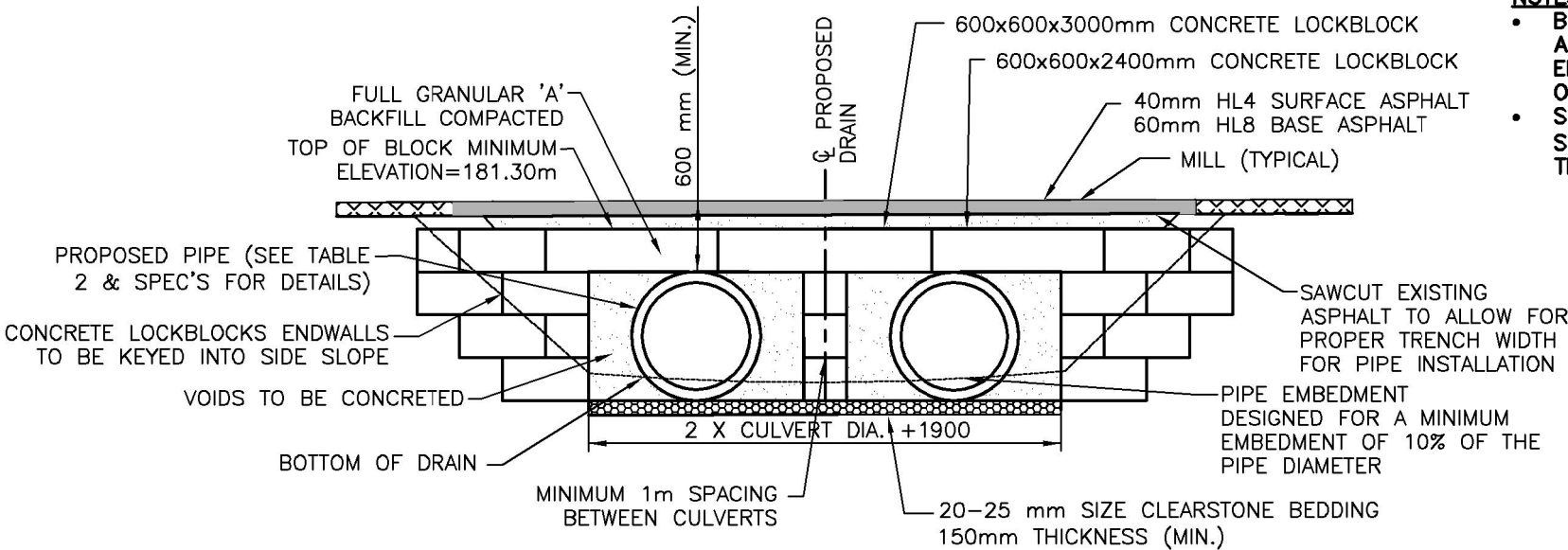

ROAD BRIDGE CROSS SECTION
BRIDGE NO. 5
NOT TO SCALE

- NOTES:**
- BLOCK END WALLS TO BE DESIGNED AND SEALED BY A PROFESSIONAL ENGINEER LICENSED IN THE PROVINCE OF ONTARIO
 - SUPPLY & INSTALL OBJECT MARKER SIGNS WA-33L/R AS PER THE ONTARIO TRAFFIC MANUAL

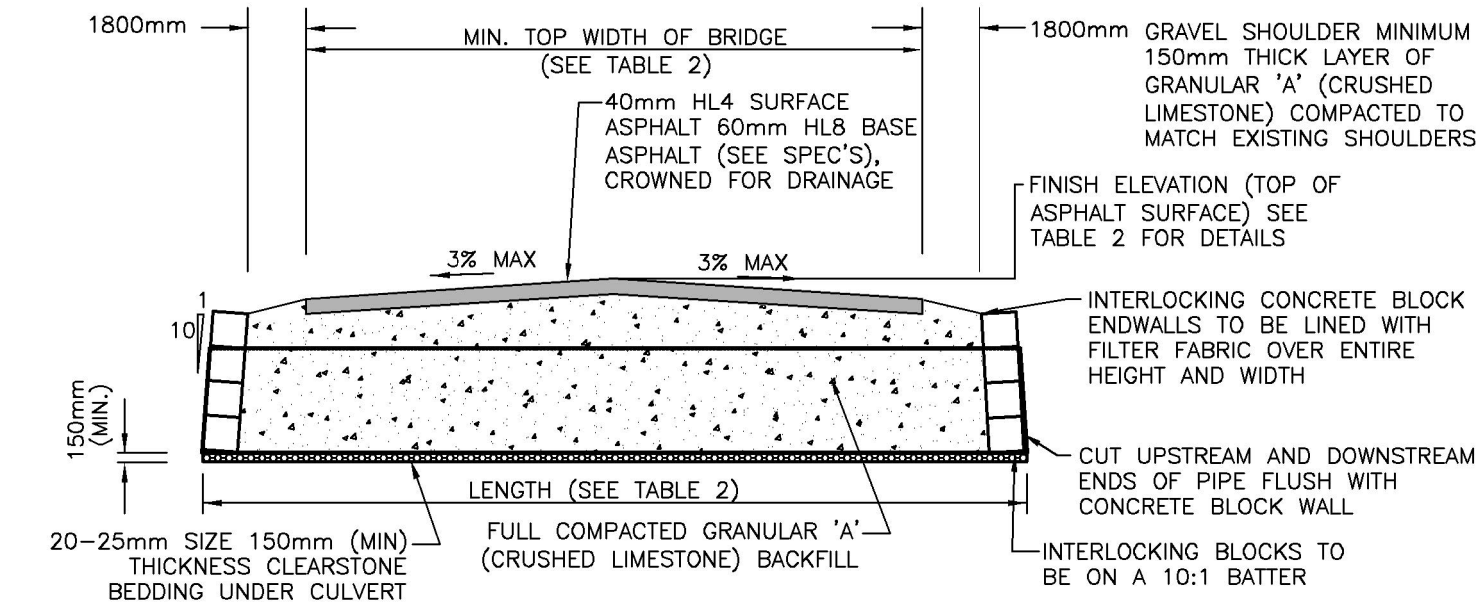

ROAD BRIDGE LONGITUDINAL SECTION
BRIDGE NO. 5
NOT TO SCALE

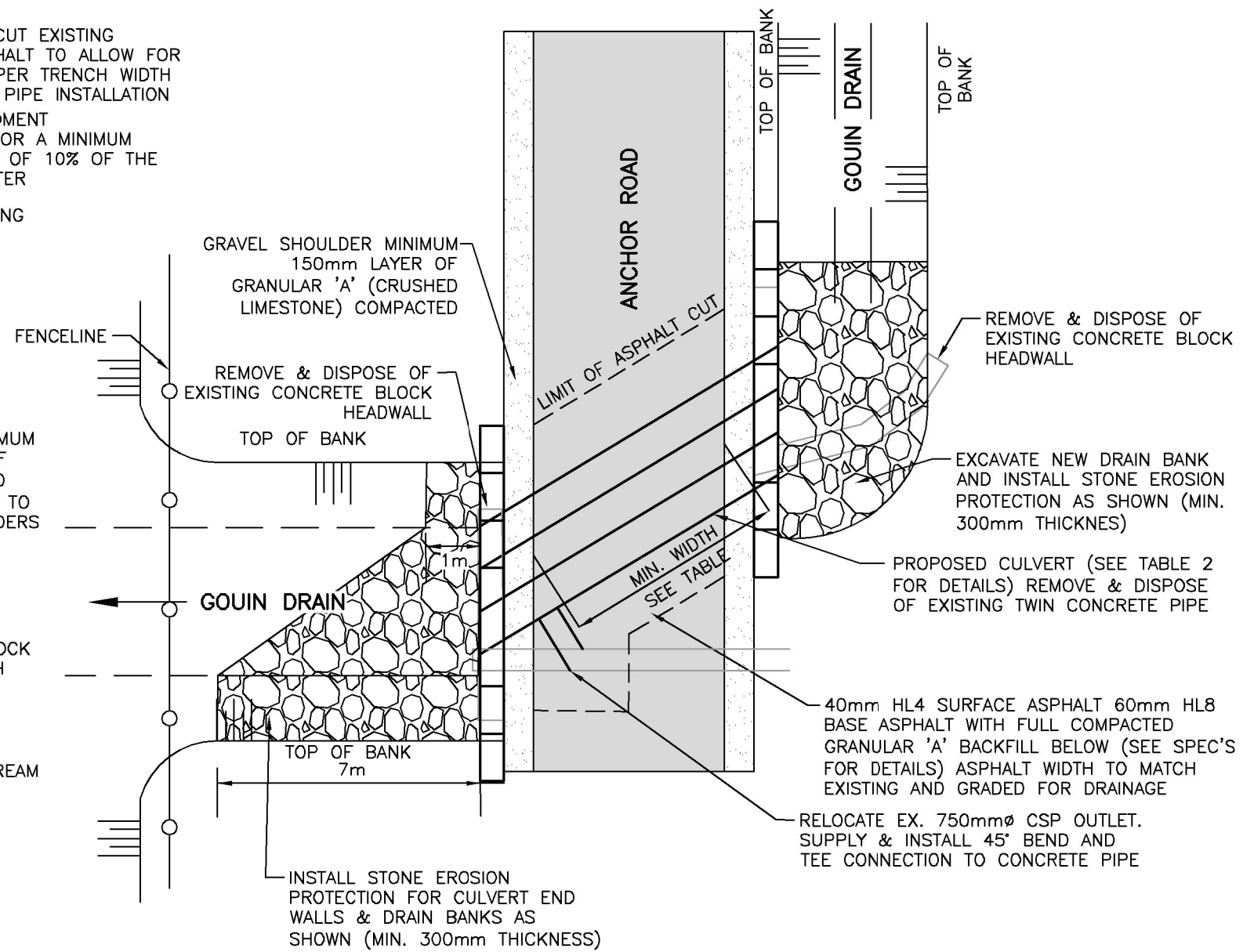

ROAD BRIDGE PLAN
BRIDGE NO. 5
NOT TO SCALE

Jan 20, 2023 - 10:08am C:\pwworking\directory\projects to 2017\330em\40611685\176773-03-PROF-DES-GOUIN.dwg



Conditions of Use

Verify elevations and/or dimensions on drawing prior to use. Report any discrepancies to Dillon Consulting Limited.

Do not scale dimensions from drawing.

Do not modify drawing, re-use it, or use it for purposes other than those intended at the time of its preparation without prior written permission from Dillon Consulting Limited.

No.	ISSUED FOR	DATE	BY
3	FINAL REPORT SUBMISSION	18 JAN 23	MDH
2	PUBLIC INFORMATION CENTRE	25 MAR 22	MDH
1	CLIENT REVIEW	4 MAR 22	MDH

DESIGN	REVIEWED BY
MDH	CDP
DRAWN	CHECKED BY
OEM	TRO
DATE	January :8, 2022
SCALE	AS SHOWN

DILLON CONSULTING

PROJECT NO. 17-6773

DRAWING SCALES BASED ON A 11" X 17" SHEET

Drainage Report for the
GOUIN DRAIN
Town of Tecumseh & City of Windsor

SHEET TITLE
FUTURE BRIDGE No. 5 REPLACEMENT

PAGE NO.
16 of 21

Jan 20, 2023 - 10:08am C:\pwworking\directory\projects to 2017\330am\c:\pwworking\directory\projects to 2017\330am\d0611685\176773-03-PROF-DES-GOUIN.dwg

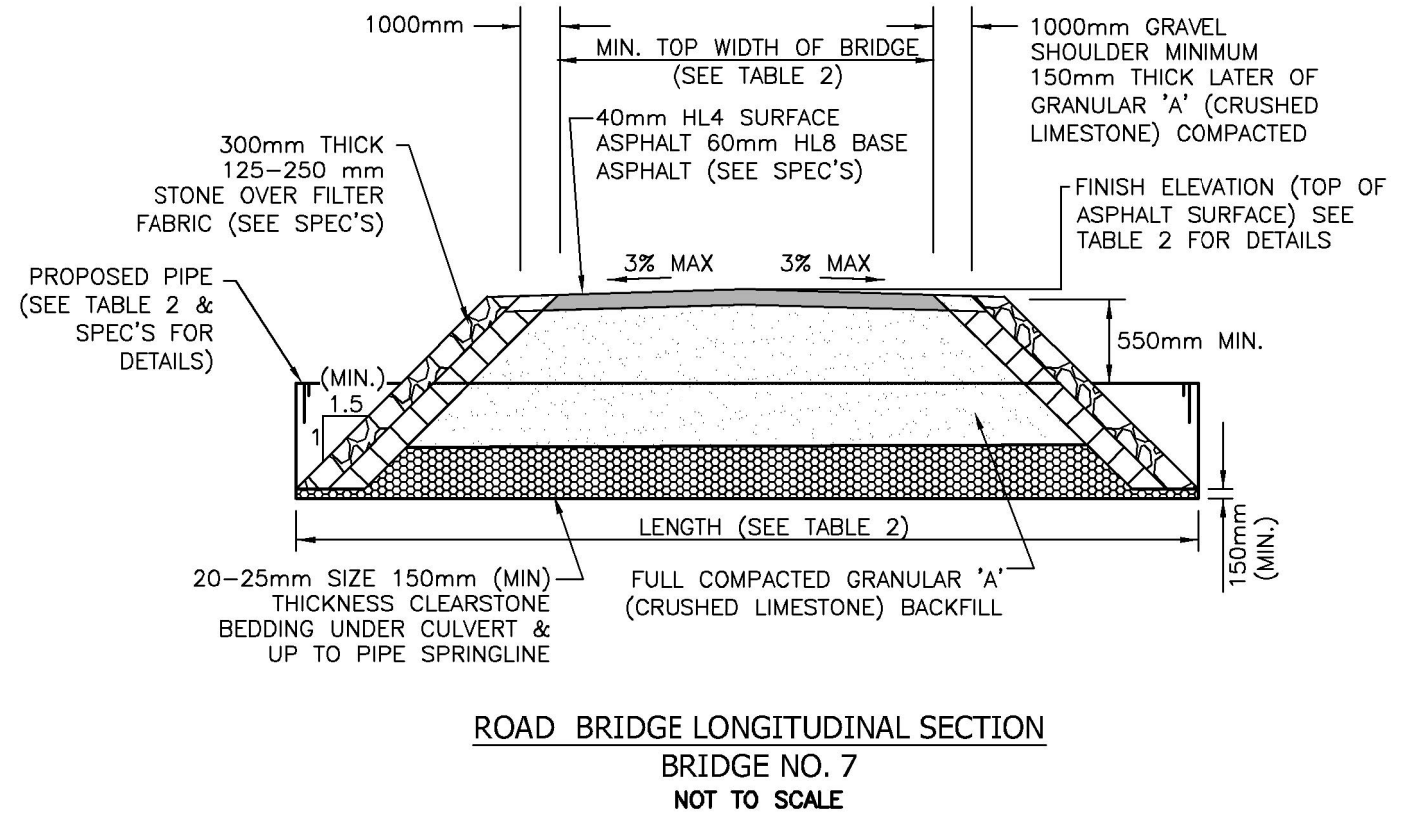
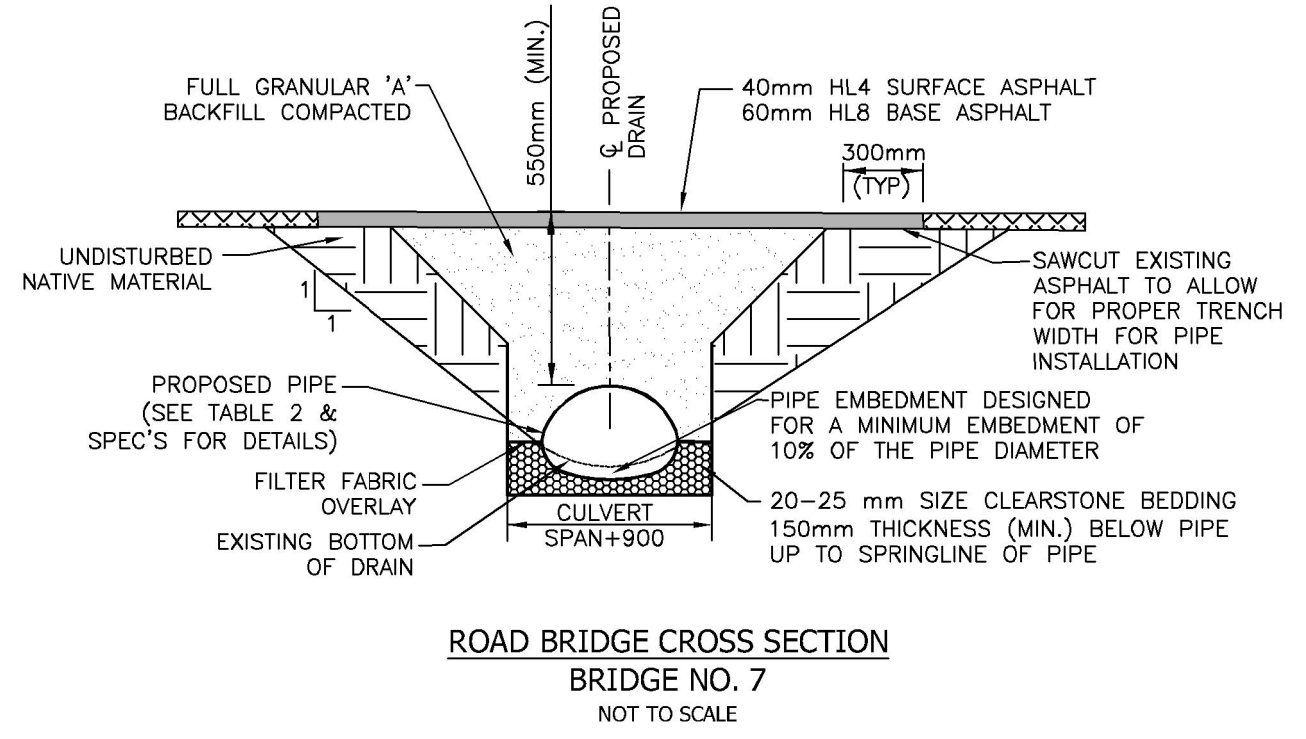
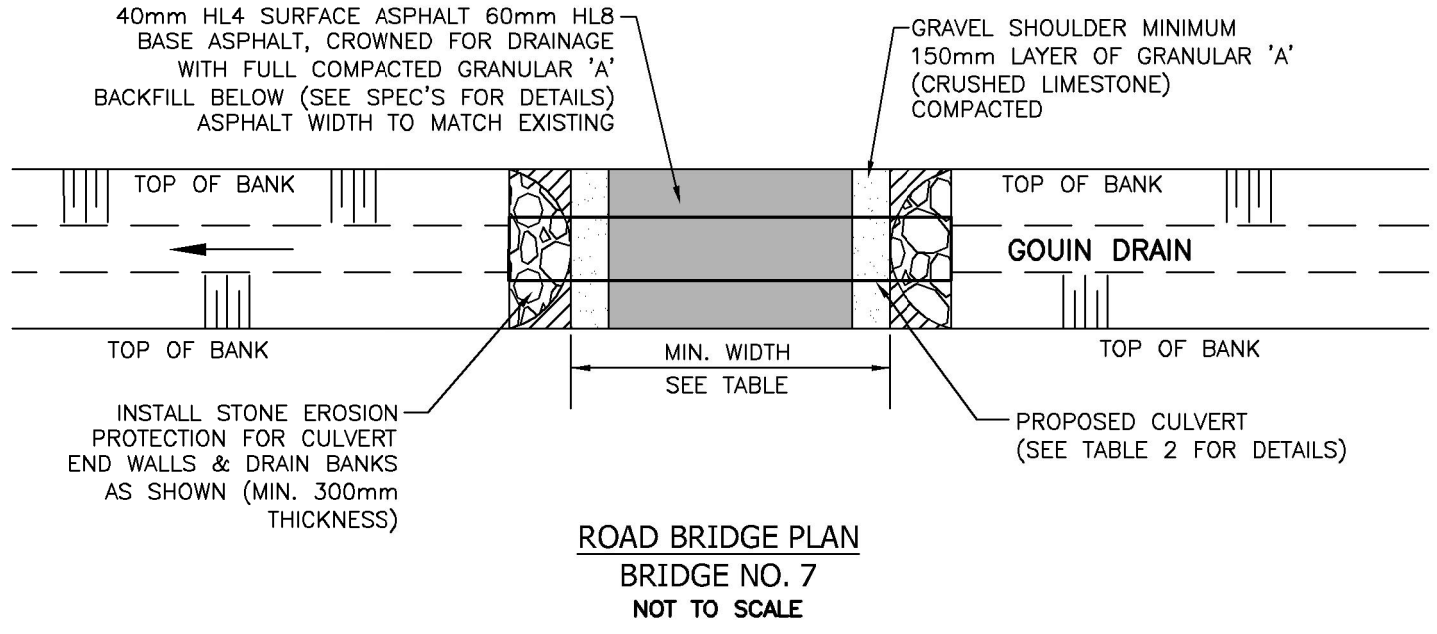

Conditions of Use
 Verify elevations and/or dimensions on drawing prior to use. Report any discrepancies to Dillon Consulting Limited.
 Do not scale dimensions from drawing.
 Do not modify drawing, re-use it, or use it for purposes other than those intended at the time of its preparation without prior written permission from Dillon Consulting Limited.

No.	ISSUED FOR	DATE	BY
3	FINAL REPORT SUBMISSION	18 JAN 23	MDH
2	PUBLIC INFORMATION CENTRE	25 MAR 22	MDH
1	CLIENT REVIEW	4 MAR 22	MDH

DESIGN	REVIEWED BY
MDH	CDP
DRAWN	CHECKED BY
OEM/OEM	TRO
DATE	January :8, 2022
SCALE	AS SHOWN

PROJECT NO. 17-6773
 DRAWING SCALES BASED ON A 11" X 17" SHEET

Drainage Report for the
GOUIN DRAIN
 Town of Tecumseh & City of Windsor

SHEET TITLE
FUTURE BRIDGE No. 7 REPLACEMENT

PAGE NO.
 17 of 21

Jan 20, 2023 - 10:08am C:\pwworking\directory\projects to 2017\336am\d0611685\176773-03-PROF-DES-GOUIN.dwg

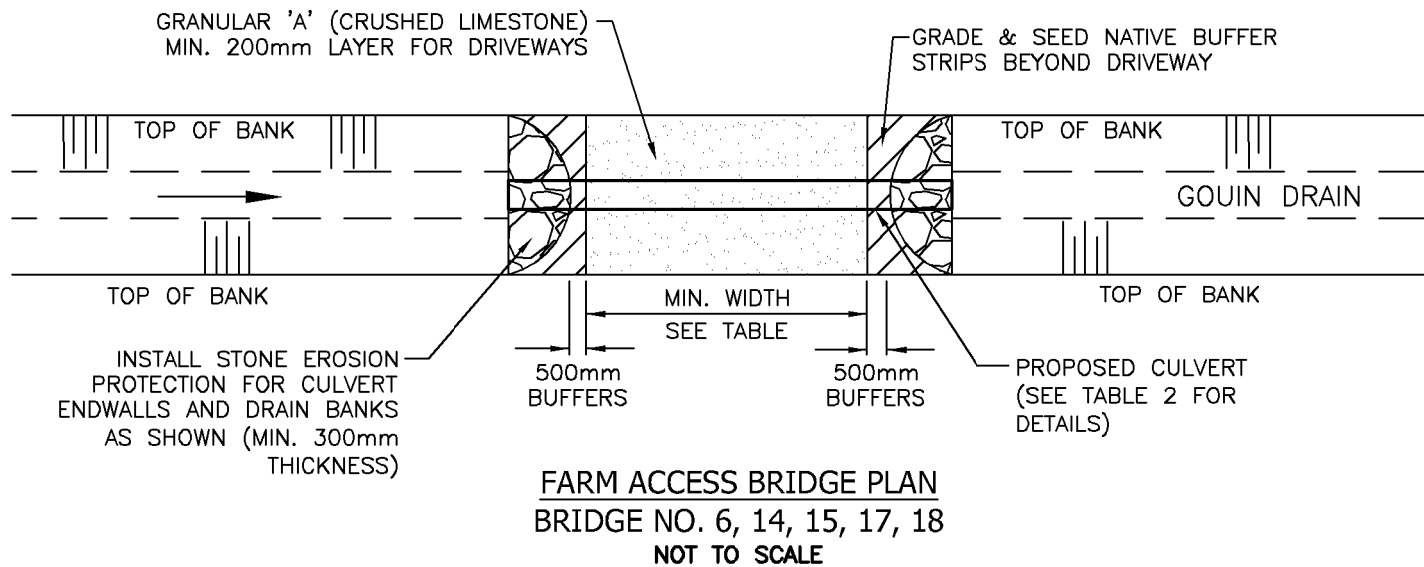

FARM ACCESS BRIDGE PLAN
BRIDGE NO. 6, 14, 15, 17, 18
NOT TO SCALE

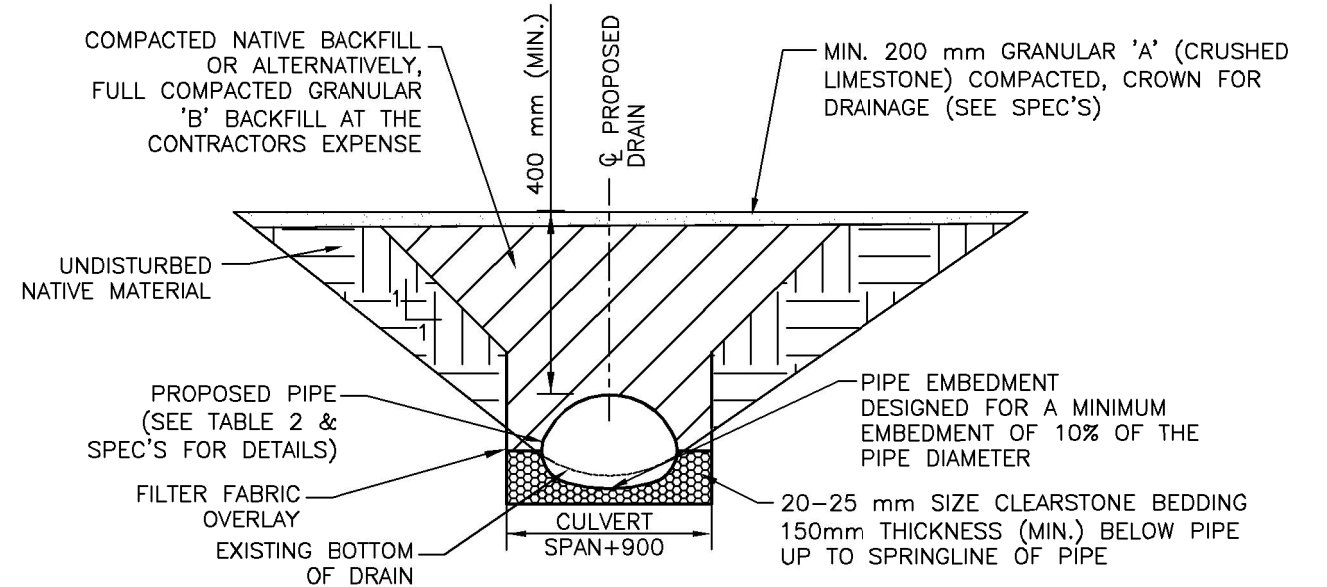

FARM ACCESS BRIDGE CROSS SECTION
BRIDGE NO. 6, 14, 15, 17, 18
NOT TO SCALE

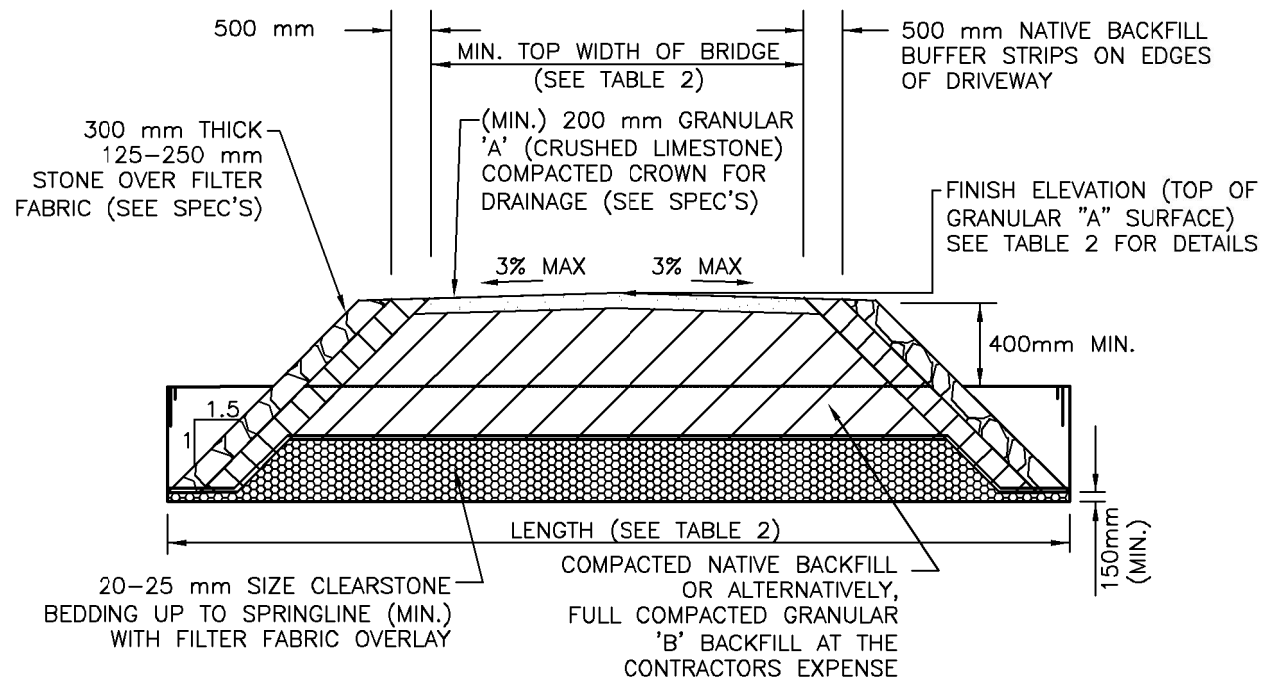

FARM ACCESS BRIDGE LONGITUDINAL SECTION
BRIDGE NO. 6, 14, 15, 17, 18
NOT TO SCALE



Conditions of Use

Verify elevations and/or dimensions on drawing prior to use. Report any discrepancies to Dillon Consulting Limited.
Do not scale dimensions from drawing.
Do not modify drawing, re-use it, or use it for purposes other than those intended at the time of its preparation without prior written permission from Dillon Consulting Limited.

No.	ISSUED FOR	DATE	BY
3	FINAL REPORT SUBMISSION	18 JAN 23	MDH
2	PUBLIC INFORMATION CENTRE	25 MAR 22	MDH
1	CLIENT REVIEW	4 MAR 22	MDH

DESIGN	MDH	REVIEWED BY	CDP
DRAWN	KAW/OEM	CHECKED BY	TRO
DATE	January :8, 2022		
SCALE	AS SHOWN		

		PROJECT NO.	17-6773
		DRAWING SCALES BASED ON A 11" X 17" SHEET	

'SCHEDULE G'	
Drainage Report for the GOUIN DRAIN Town of Tecumseh & City of Windsor	
SHEET TITLE	FUTURE BRIDGE No. 6, 14, 15, 17, 18 REPLACEMENT
PAGE NO.	18 of 21

NOTES:

- BLOCK END WALLS TO BE DESIGNED AND SEALED BY A PROFESSIONAL ENGINEER LICENSED IN THE PROVINCE OF ONTARIO
- SUPPLY & INSTALL OBJECT MARKER SIGNS WA-33L/R AS PER THE ONTARIO TRAFFIC MANUAL

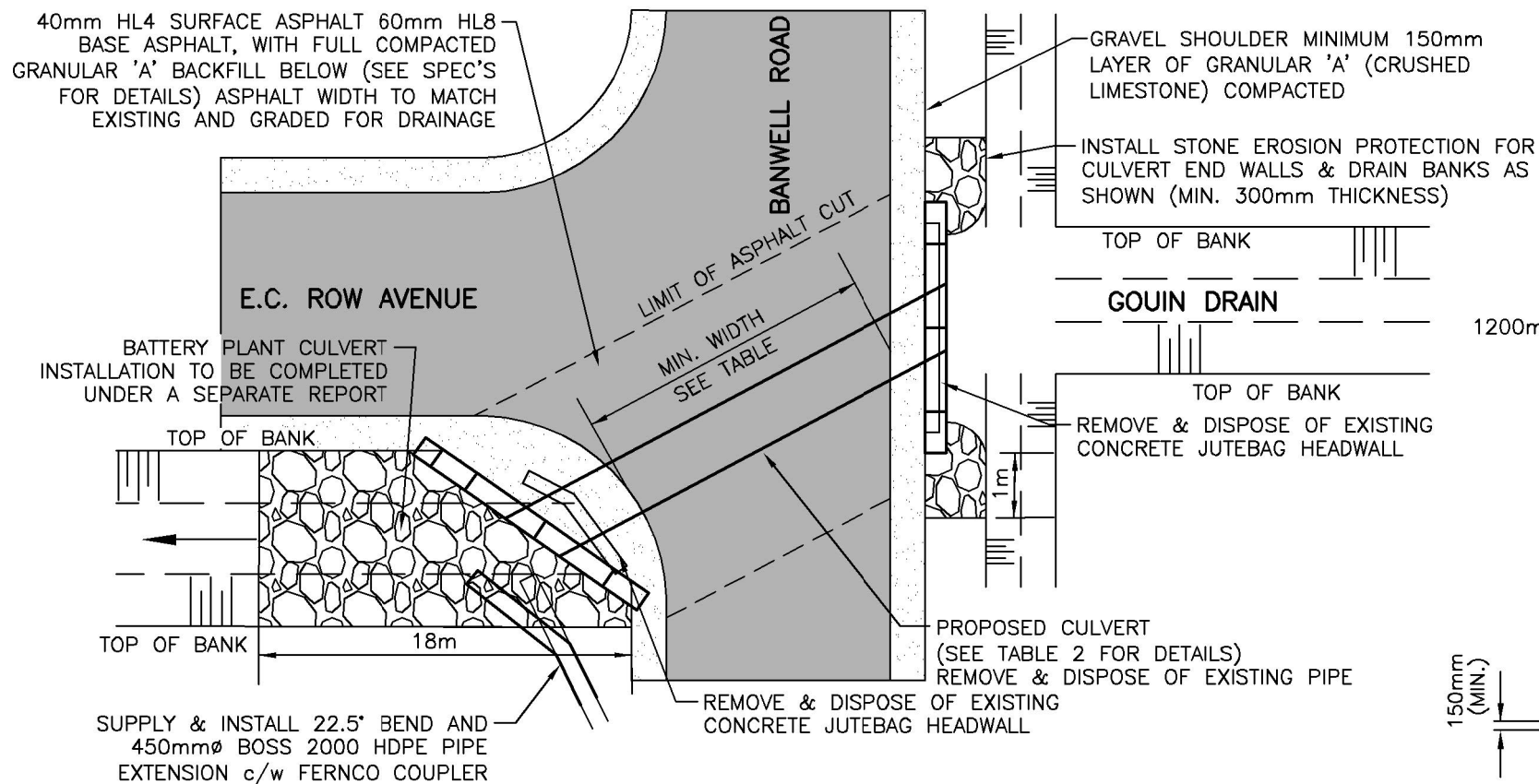

**ROAD BRIDGE PLAN
BRIDGE NO. 13
NOT TO SCALE**

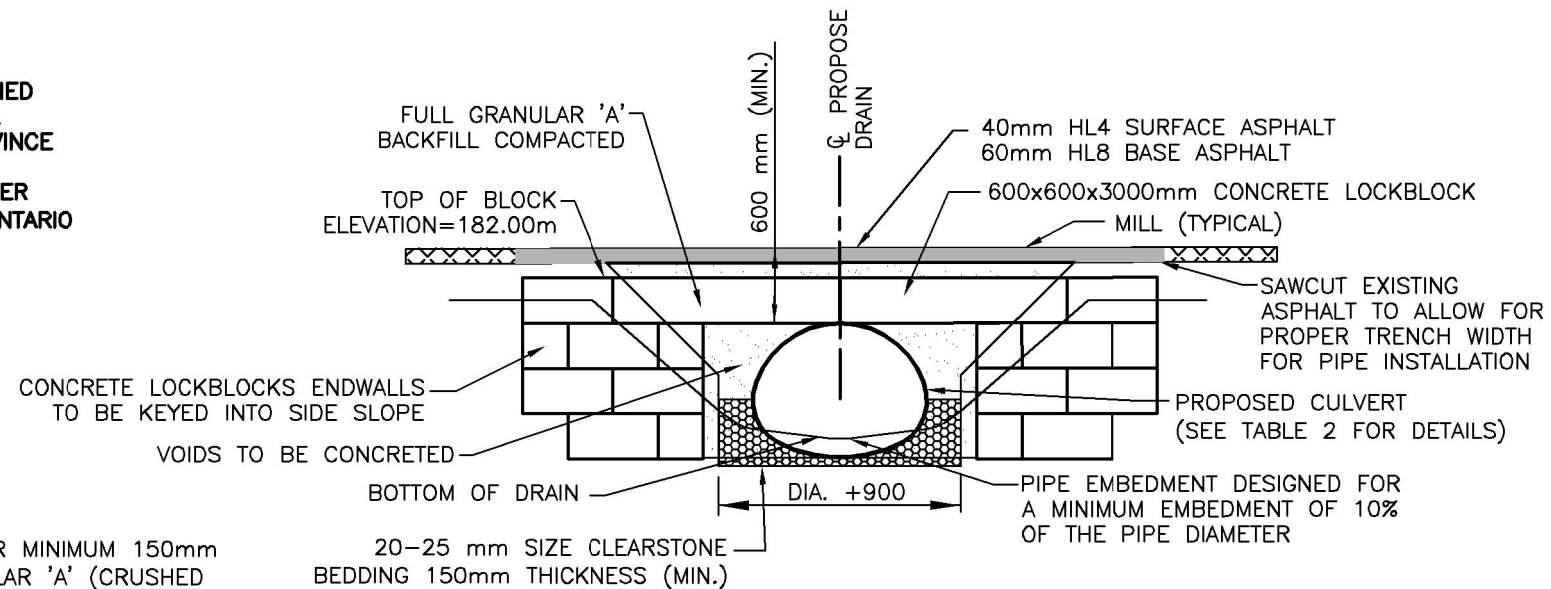

**ROAD BRIDGE CROSS SECTION
BRIDGE NO. 13
NOT TO SCALE**

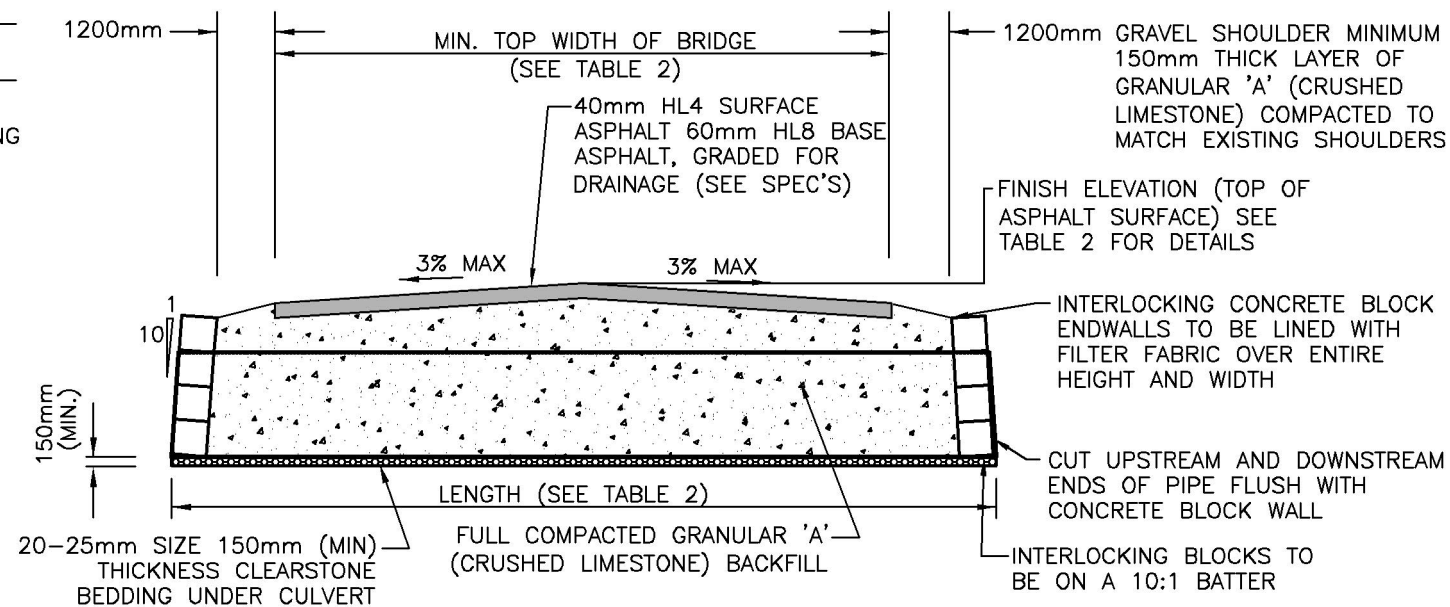

**ROAD BRIDGE LONGITUDINAL SECTION
BRIDGE NO. 13
NOT TO SCALE**

Jan 20, 2023 - 10:08am C:\pwworking\directory\projects to 2017\330am\d0611685\176773-03-PROF-DES-GOUIN.dwg



Conditions of Use

Verify elevations and/or dimensions on drawing prior to use. Report any discrepancies to Dillon Consulting Limited.
Do not scale dimensions from drawing.
Do not modify drawing, re-use it, or use it for purposes other than those intended at the time of its preparation without prior written permission from Dillon Consulting Limited.

No.	ISSUED FOR	DATE	BY
3	FINAL REPORT SUBMISSION	18 JAN 23	MDH
2	PUBLIC INFORMATION CENTRE	25 MAR 22	MDH
1	CLIENT REVIEW	4 MAR 22	MDH

DESIGN	MDH	REVIEWED BY	CDP
DRAWN	OEM	CHECKED BY	TRO
DATE	January :8, 2022		
SCALE	AS SHOWN		

DILLON CONSULTING

PROJECT NO. 17-6773

DRAWING SCALES BASED ON A 11" X 17" SHEET

Drainage Report for the
GOUIN DRAIN
Town of Tecumseh & City of Windsor

SHEET TITLE
FUTURE BRIDGE No. 13 REPLACEMENT

PAGE NO.
19 of 21

Jan 20, 2023 - 10:09am C:\pwworking\directory\projects to 2017\330am\d0611685\176773-03-PROF-DES-GOUIN.dwg

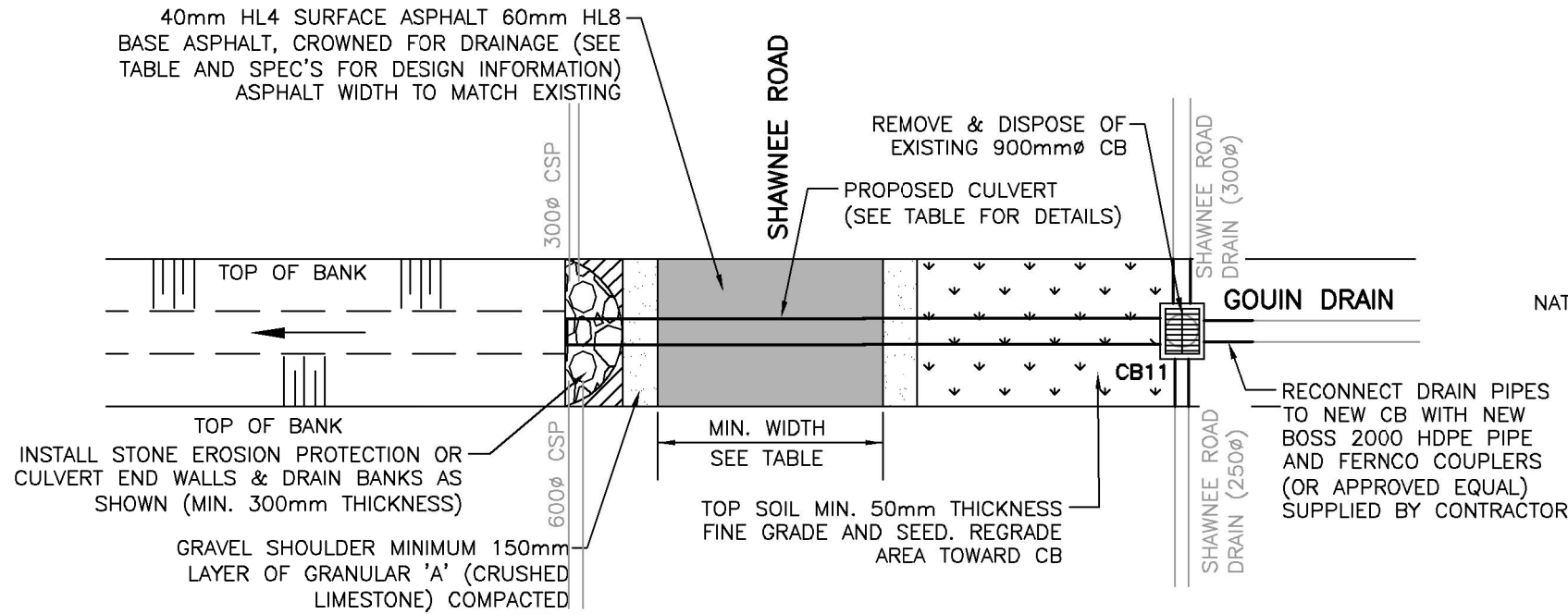

ROAD BRIDGE PLAN
BRIDGE NO. 20
NOT TO SCALE

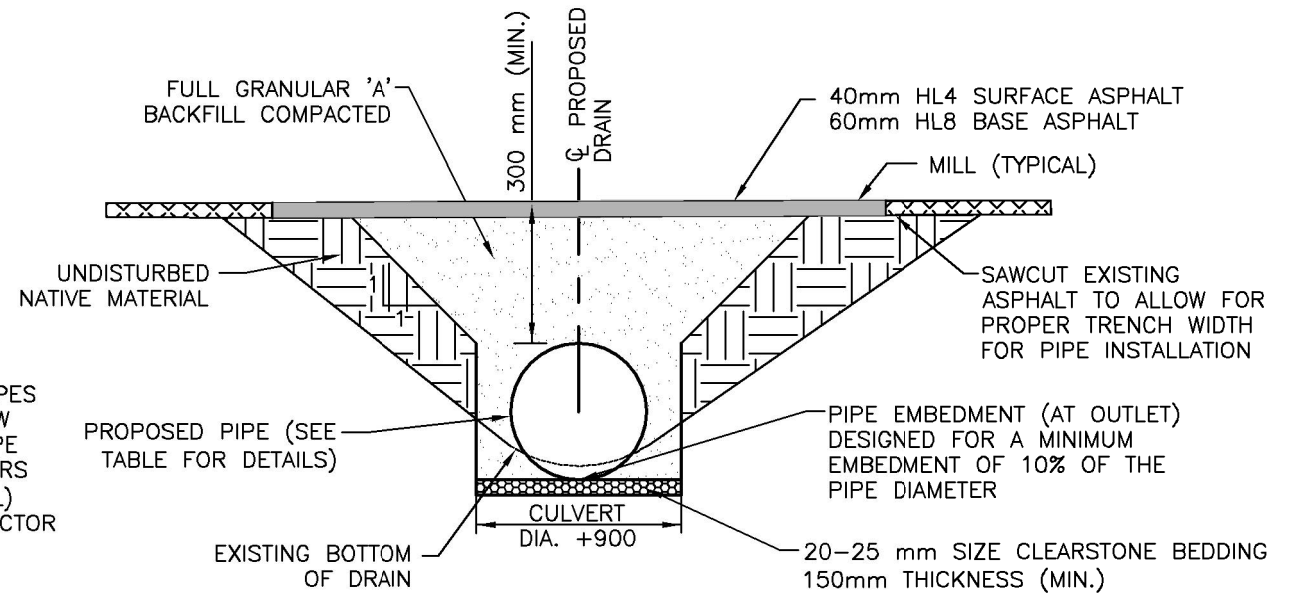

ROAD BRIDGE CROSS SECTION
BRIDGE NO. 20
NOT TO SCALE

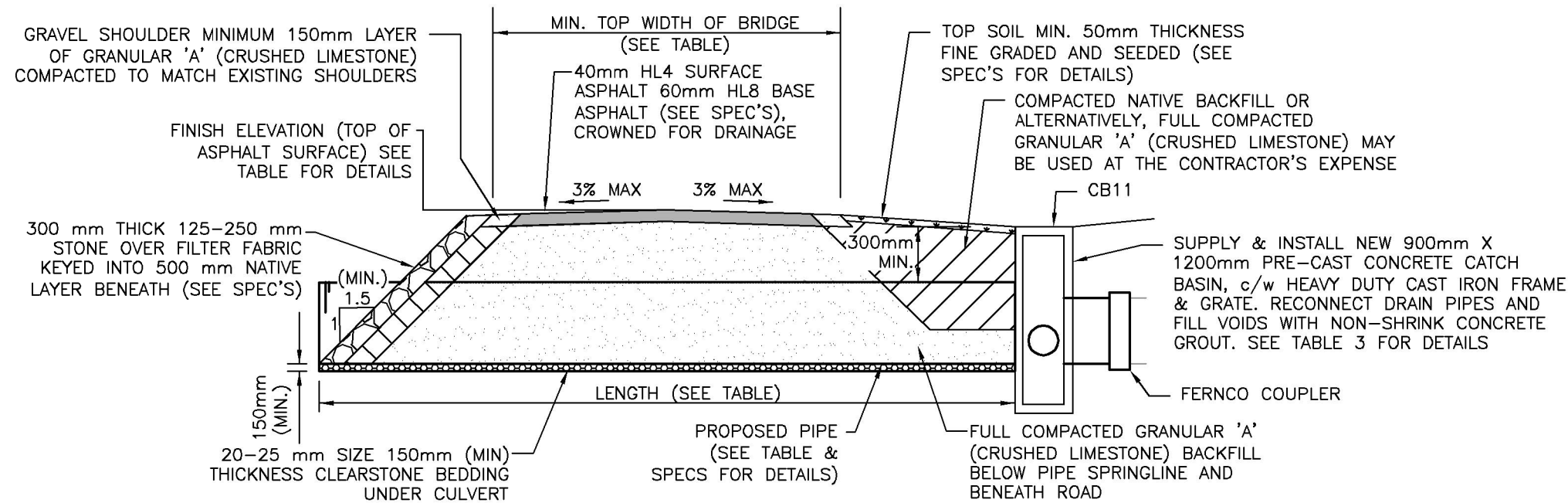

ROAD BRIDGE LONGITUDINAL SECTION
BRIDGE NO. 20
NOT TO SCALE

TABLE 3 - CATCH BASIN DETAILS	
DESCRIPTION	CB11
SIZE (mm)	900x1200
GRATE	HEAVY DUTY
RIM ELEVATION (m)	182.71
INVERTS (m)	181.42 300ø(N)
	181.41 250ø(S)
	181.38 600ø(E)
	181.38 750ø(W)



Conditions of Use

Verify elevations and/or dimensions on drawing prior to use. Report any discrepancies to Dillon Consulting Limited.
Do not scale dimensions from drawing.
Do not modify drawing, re-use it, or use it for purposes other than those intended at the time of its preparation without prior written permission from Dillon Consulting Limited.

No.	ISSUED FOR	DATE	BY
3	FINAL REPORT SUBMISSION	18 JAN 23	MDH
2	PUBLIC INFORMATION CENTRE	25 MAR 22	MDH
1	CLIENT REVIEW	4 MAR 22	MDH

DESIGN	MDH	REVIEWED BY	CDP
DRAWN	OEM	CHECKED BY	TRO
DATE	January :8, 2022		
SCALE	AS SHOWN		

	PROJECT NO.	17-6773
	DRAWING SCALES BASED ON A 11" X 17" SHEET	

Drainage Report for the GOUIN DRAIN Town of Tecumseh & City of Windsor	
SHEET TITLE	FUTURE BRIDGE No. 20 REPLACEMENT
PAGE NO.	20 of 21

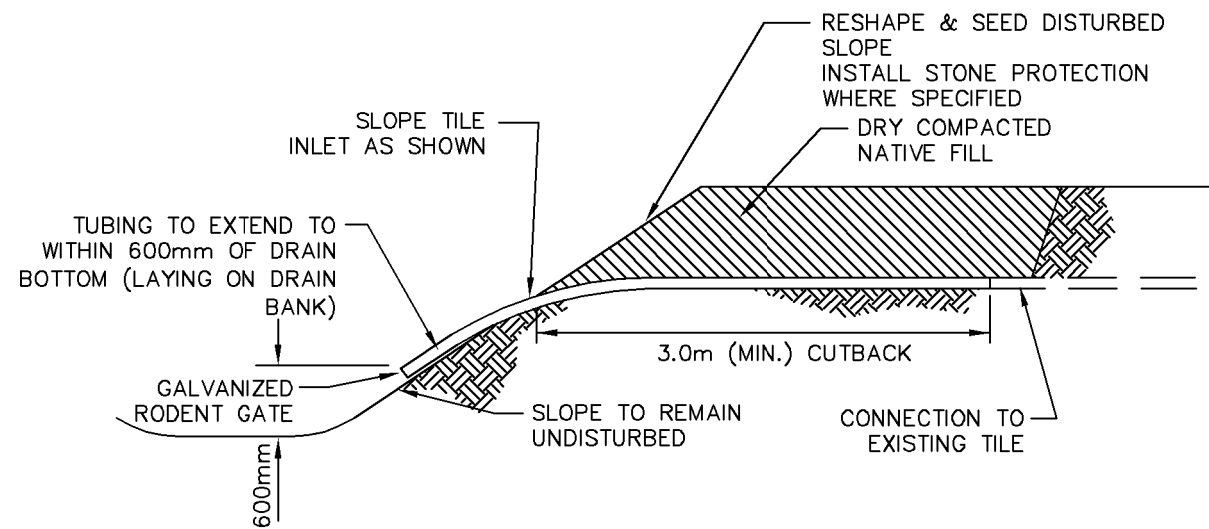

TILE DRAINAGE TUBING TILE INLET REPLACEMENT DETAIL
(FOR TILES 150mmØ OR SMALLER)
N.T.S.

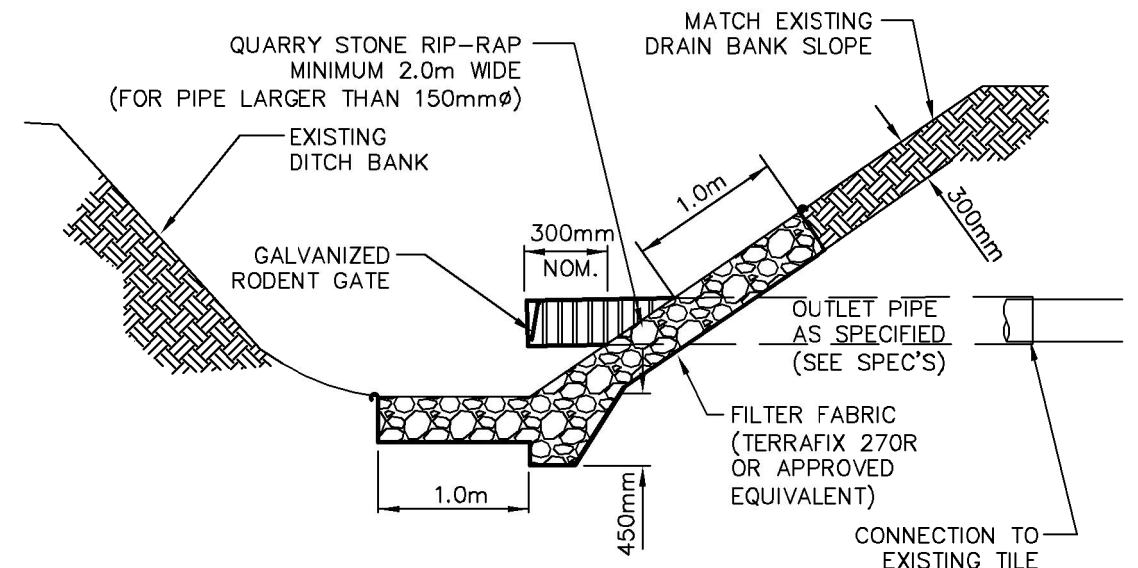

TYPICAL CSP TILE INLET REPLACEMENT DETAIL
N.T.S.

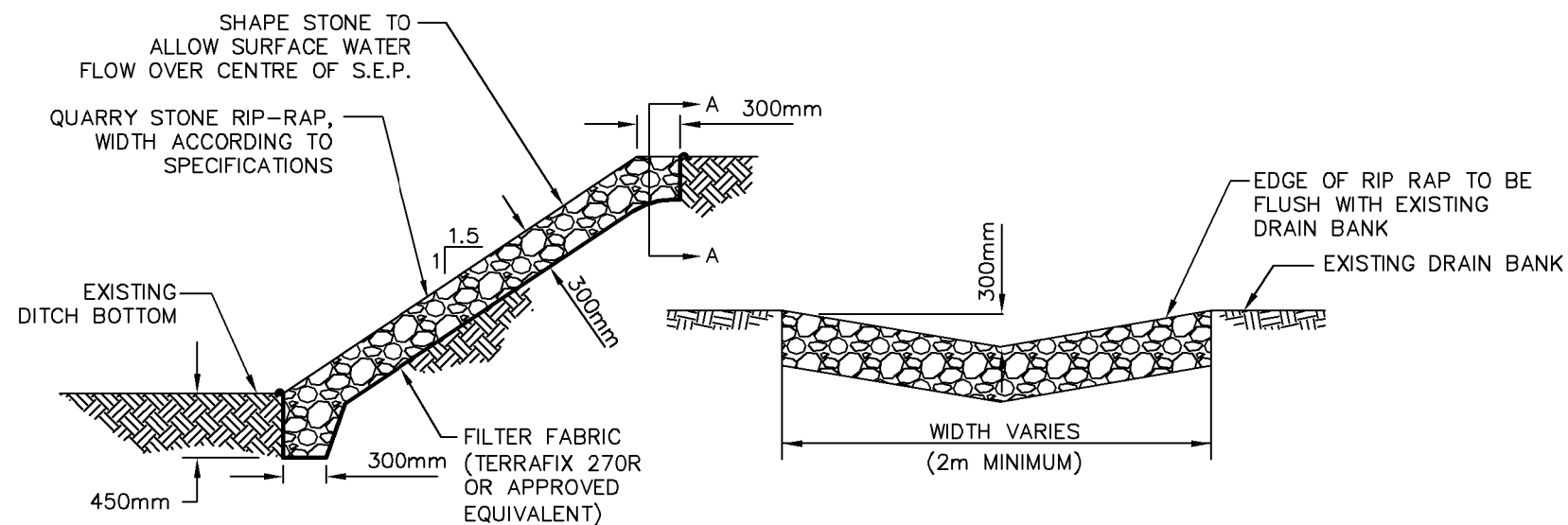

TYPICAL DITCH BANK WASHOUT DETAIL w/ RIP RAP
N.T.S.

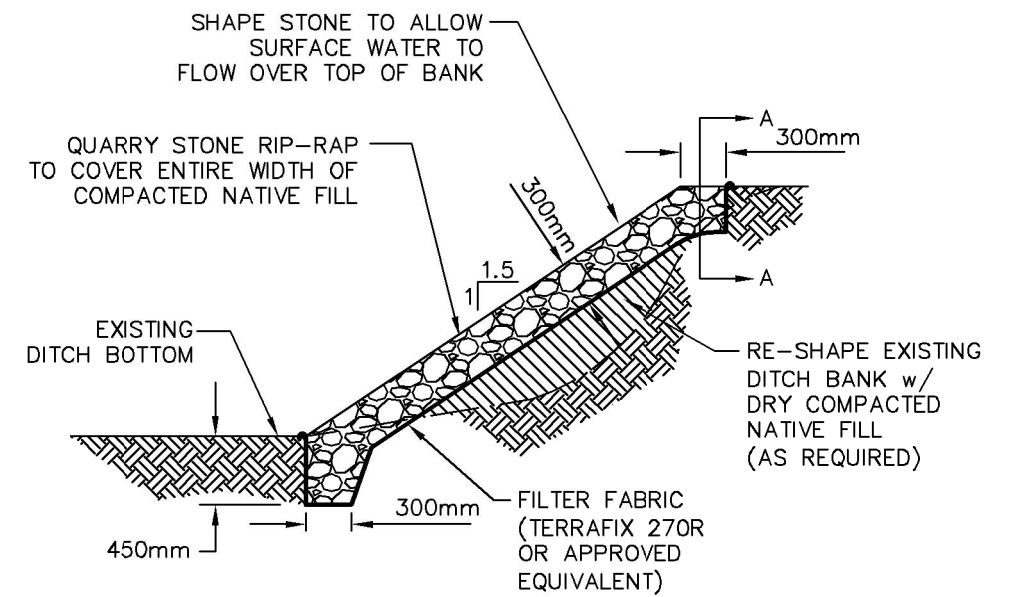

TYPICAL DITCH BANK WASHOUT DETAIL w/ BACKFILLING & RIP RAP
N.T.S.

Jan 20, 2023 - 10:09am C:\pwworking\directory\projects to 2017\330am\d0611685\176773-03-PROF-DES-COULN.dwg



Conditions of Use

Verify elevations and/or dimensions on drawing prior to use. Report any discrepancies to Dillon Consulting Limited.
Do not scale dimensions from drawing.
Do not modify drawing, re-use it, or use it for purposes other than those intended at the time of its preparation without prior written permission from Dillon Consulting Limited.

No.	ISSUED FOR	DATE	BY
3	FINAL REPORT SUBMISSION	18 JAN 23	MDH
2	PUBLIC INFORMATION CENTRE	25 MAR 22	MDH
1	CLIENT REVIEW	4 MAR 22	MDH

DESIGN	MDH	REVIEWED BY	CDP
DRAWN	OEM	CHECKED BY	TRO
DATE	January 18, 2022		
SCALE	AS SHOWN		

		PROJECT NO.	17-6773
		DRAWING SCALES BASED ON A 11" X 17" SHEET	

Drainage Report for the GOUIN DRAIN Town of Tecumseh & City of Windsor	
SHEET TITLE	MISCELLANEOUS DETAILS
PAGE NO.	21 of 21