

0 500 1000 2000 metres  
 prepared by Prince, Silani and Associates Ltd.

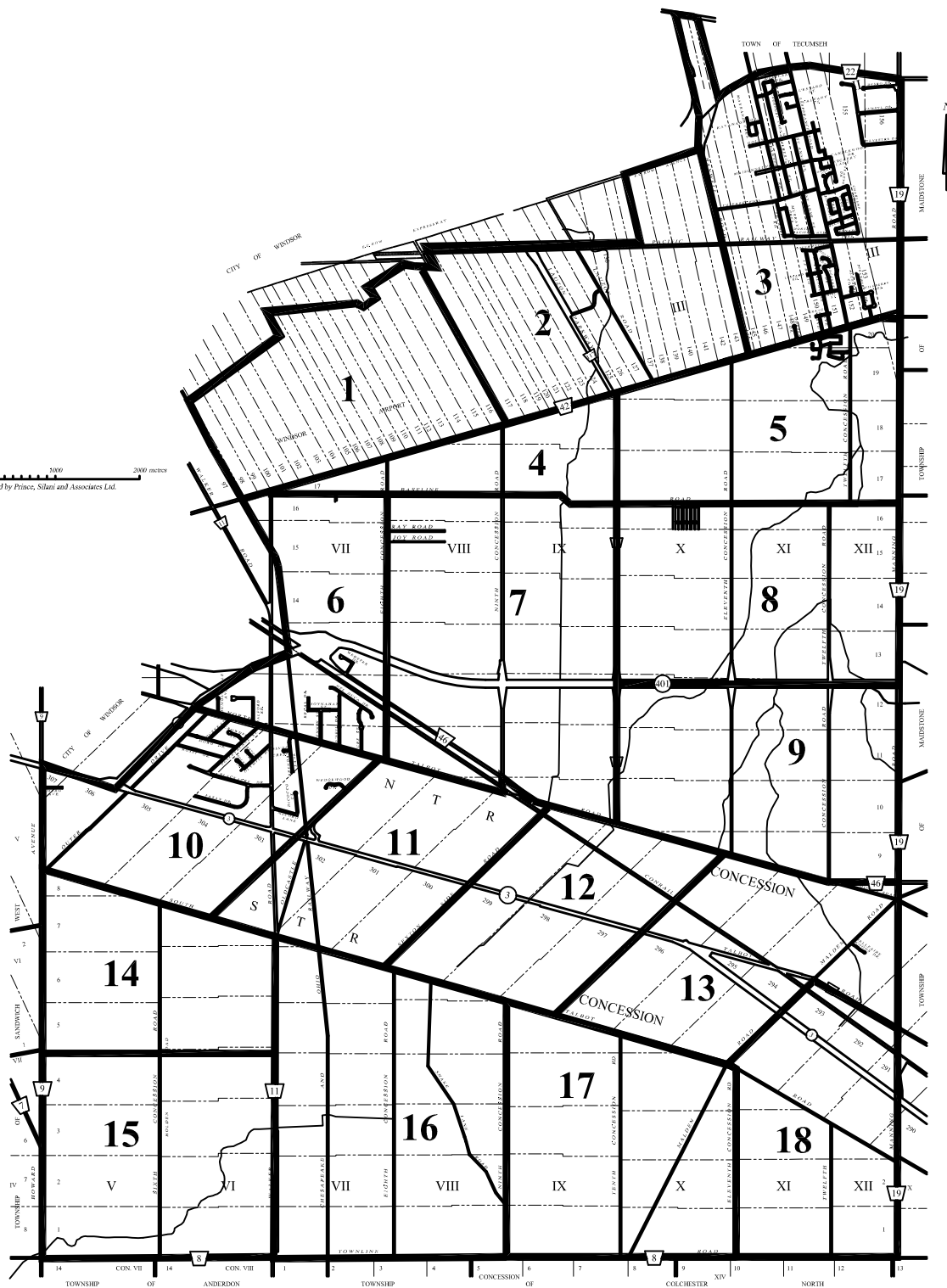

**ZONE LEGEND**

- R1 Residential Zone 1
- R2 Residential Zone 2
- RH Hamlet Residential
- C1 General Commercial
- C2 Neighbourhood Commercial
- C3 Highway and Service Commercial
- CH Hamlet Commercial
- CR Rural Commercial
- CM Commercial/Industrial

- BP Business Park
- CMH Hamlet Commercial/Industrial
- M1 Industrial
- HS Highway Service Centre
- A Agricultural
- I Institutional
- P Parks and Open Space
- (H) Holding Zone

Floodplain Development Control Area  
 (See Subsection 5.40)

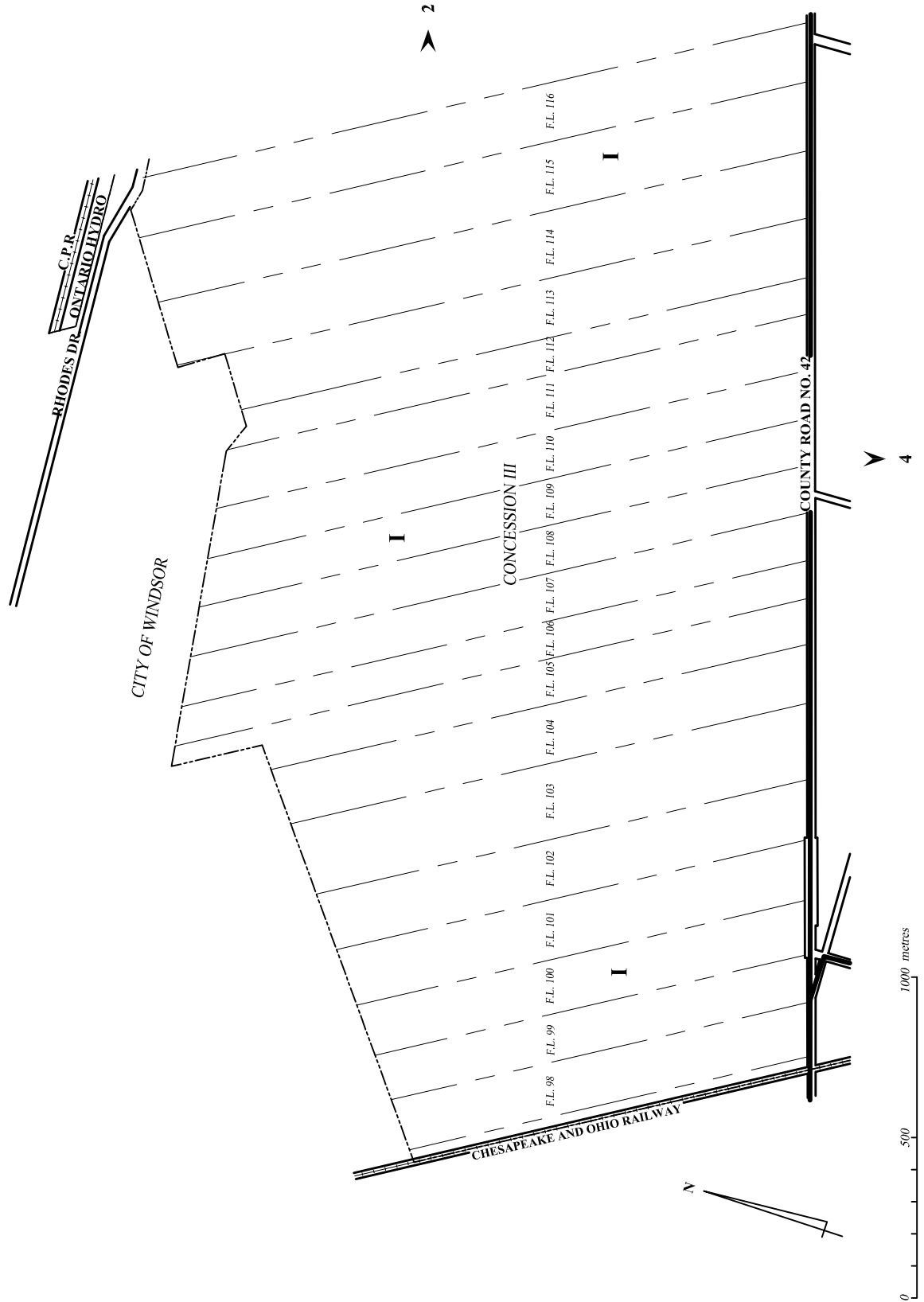

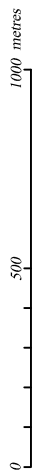
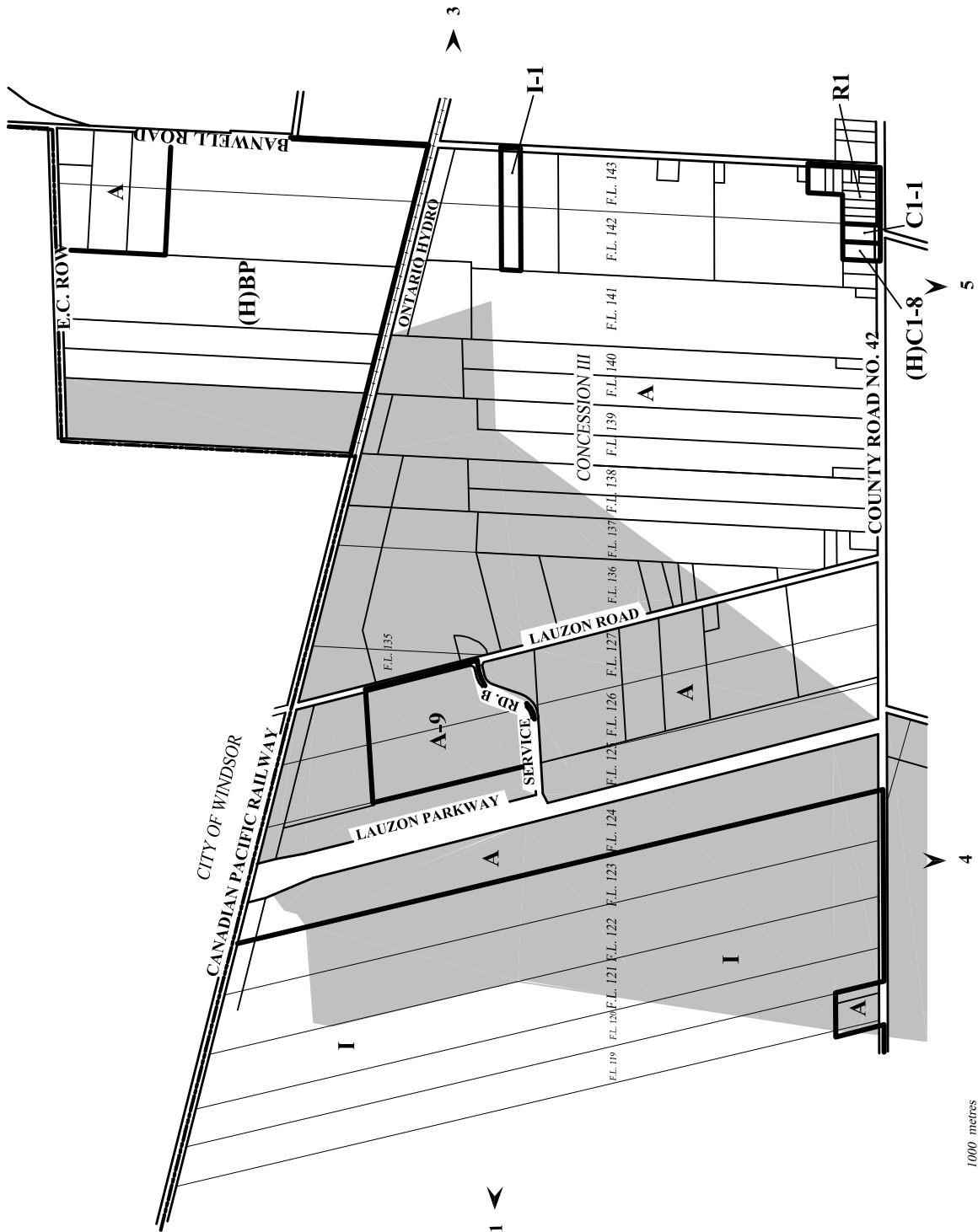



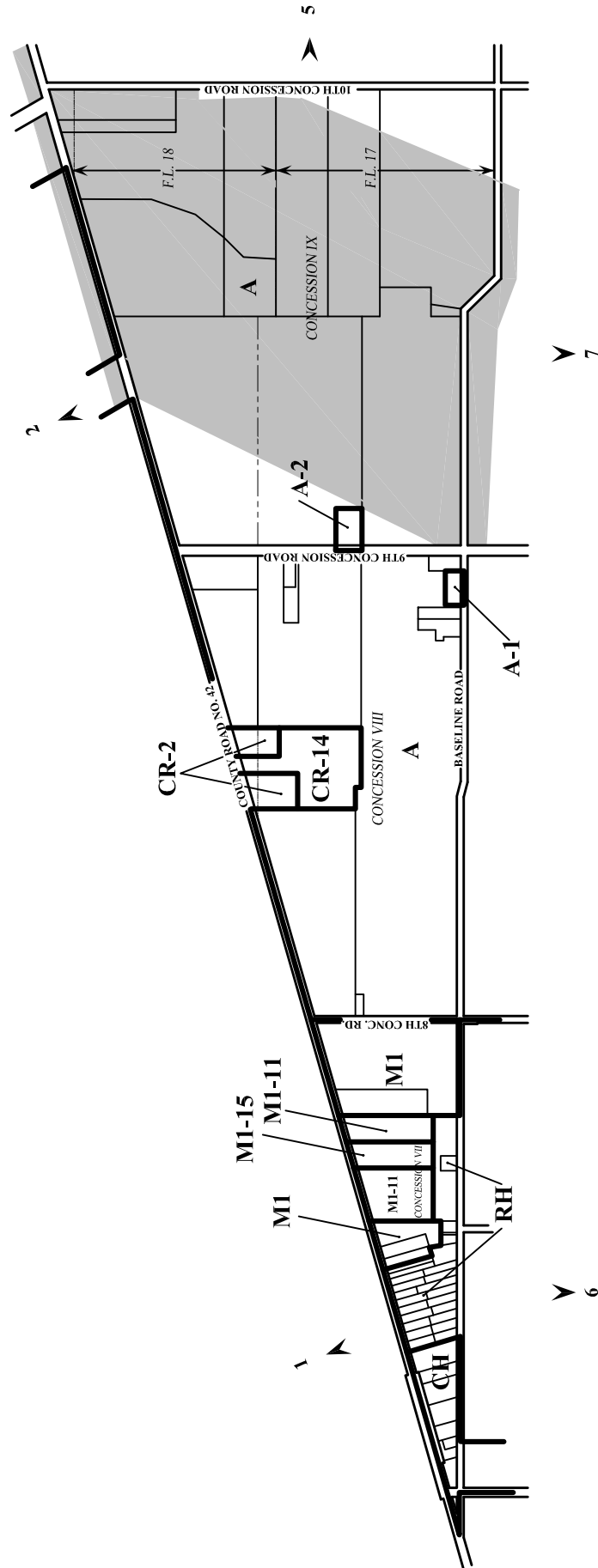
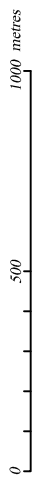

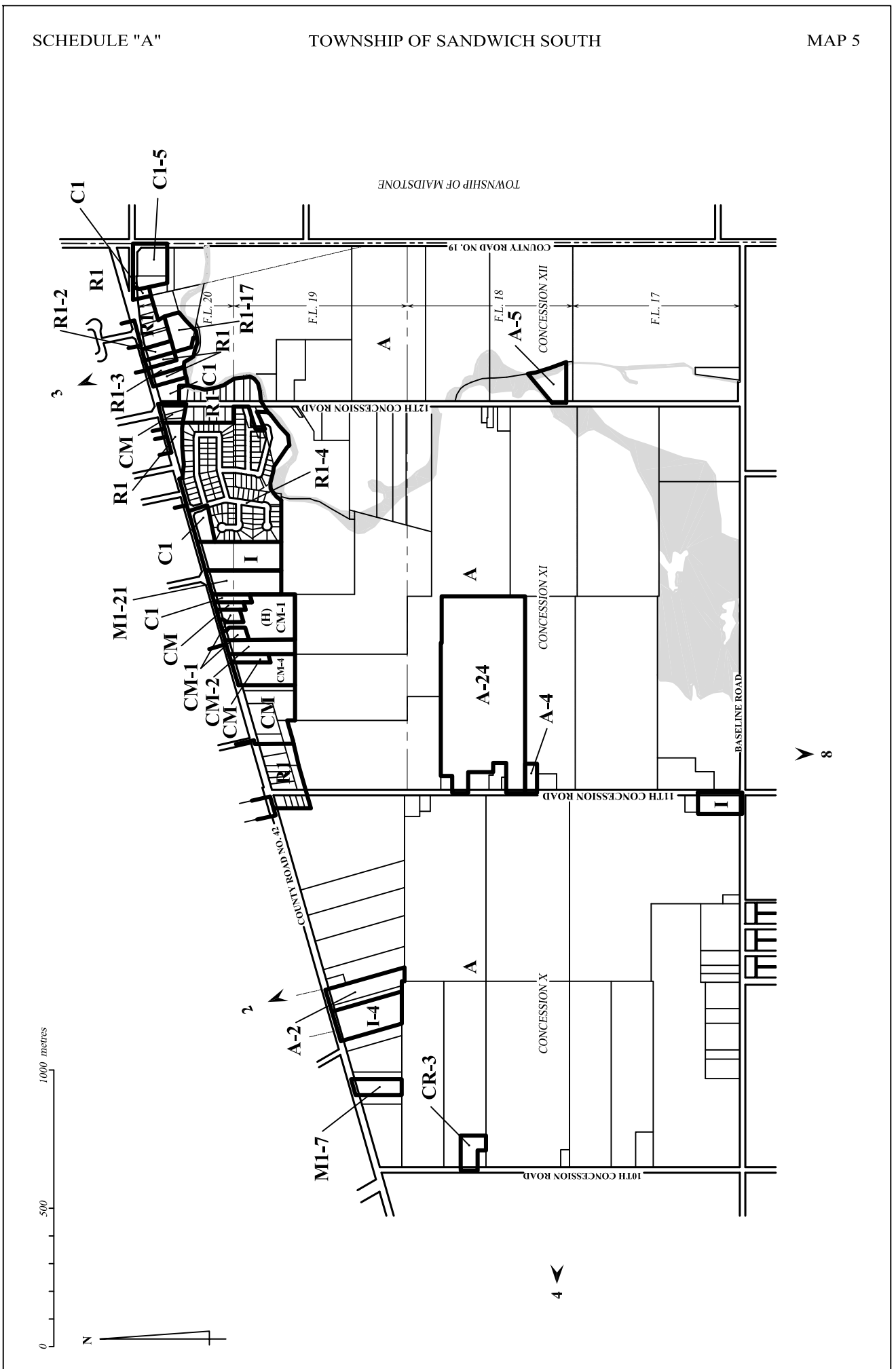

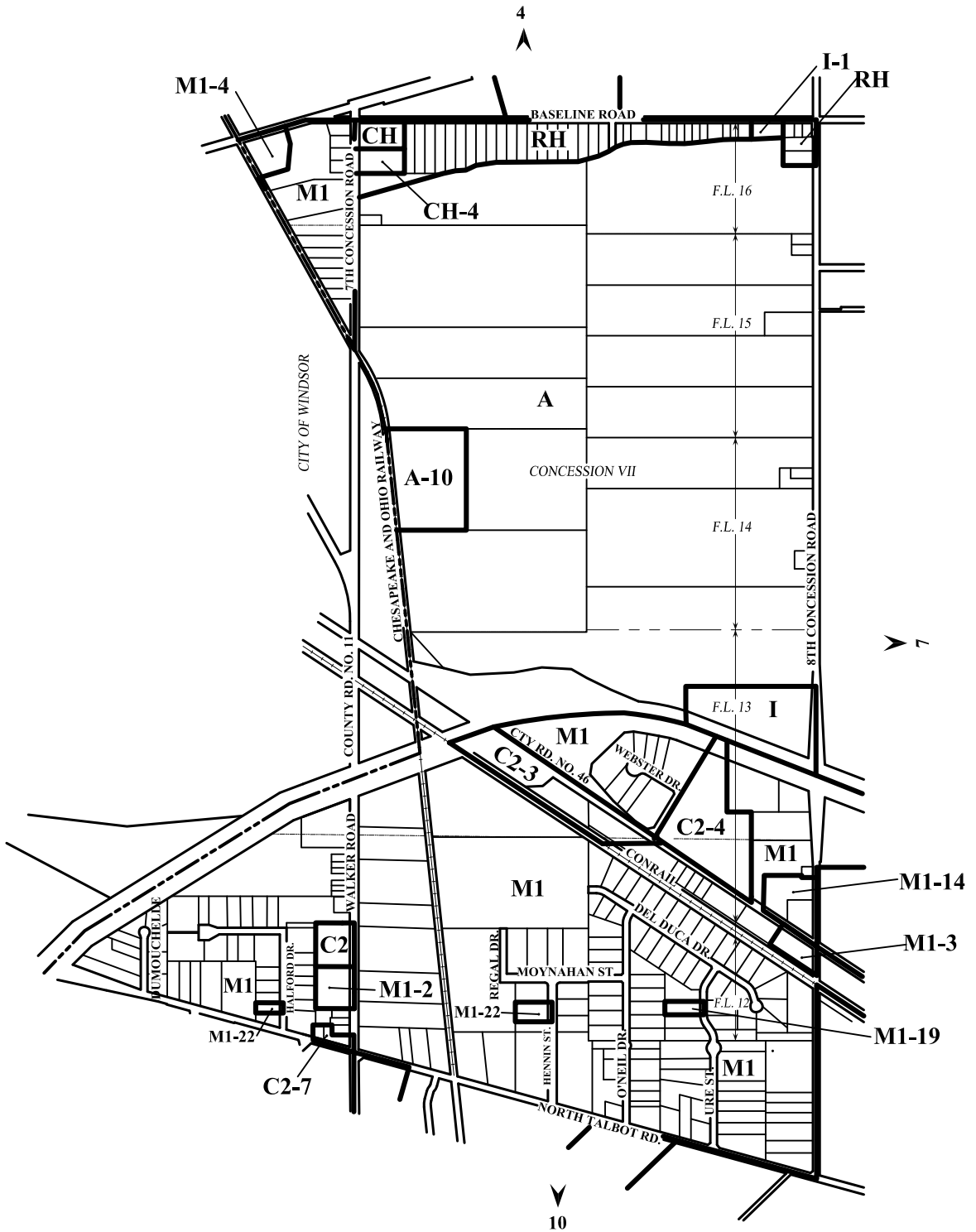

0 500 1000 metres



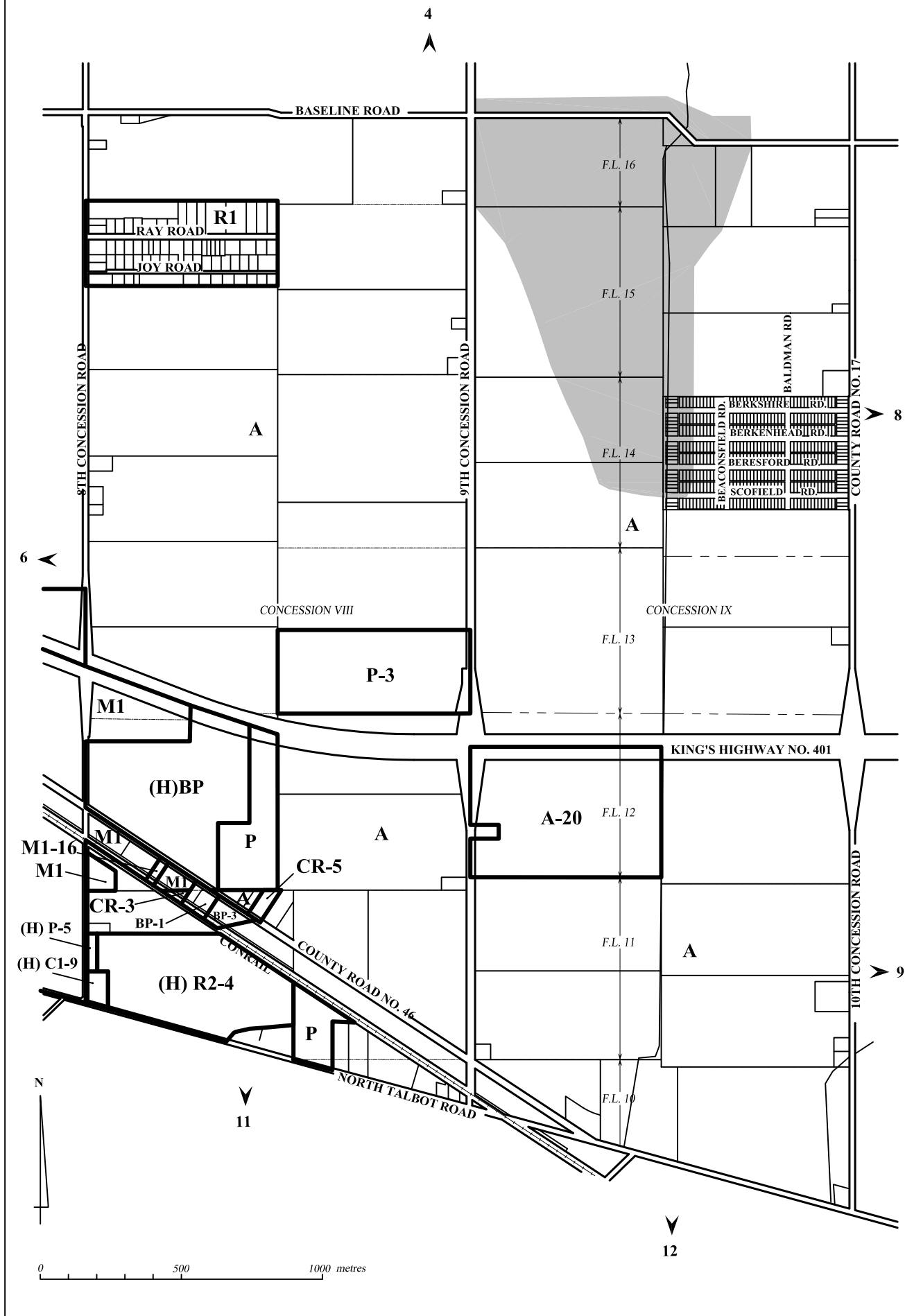



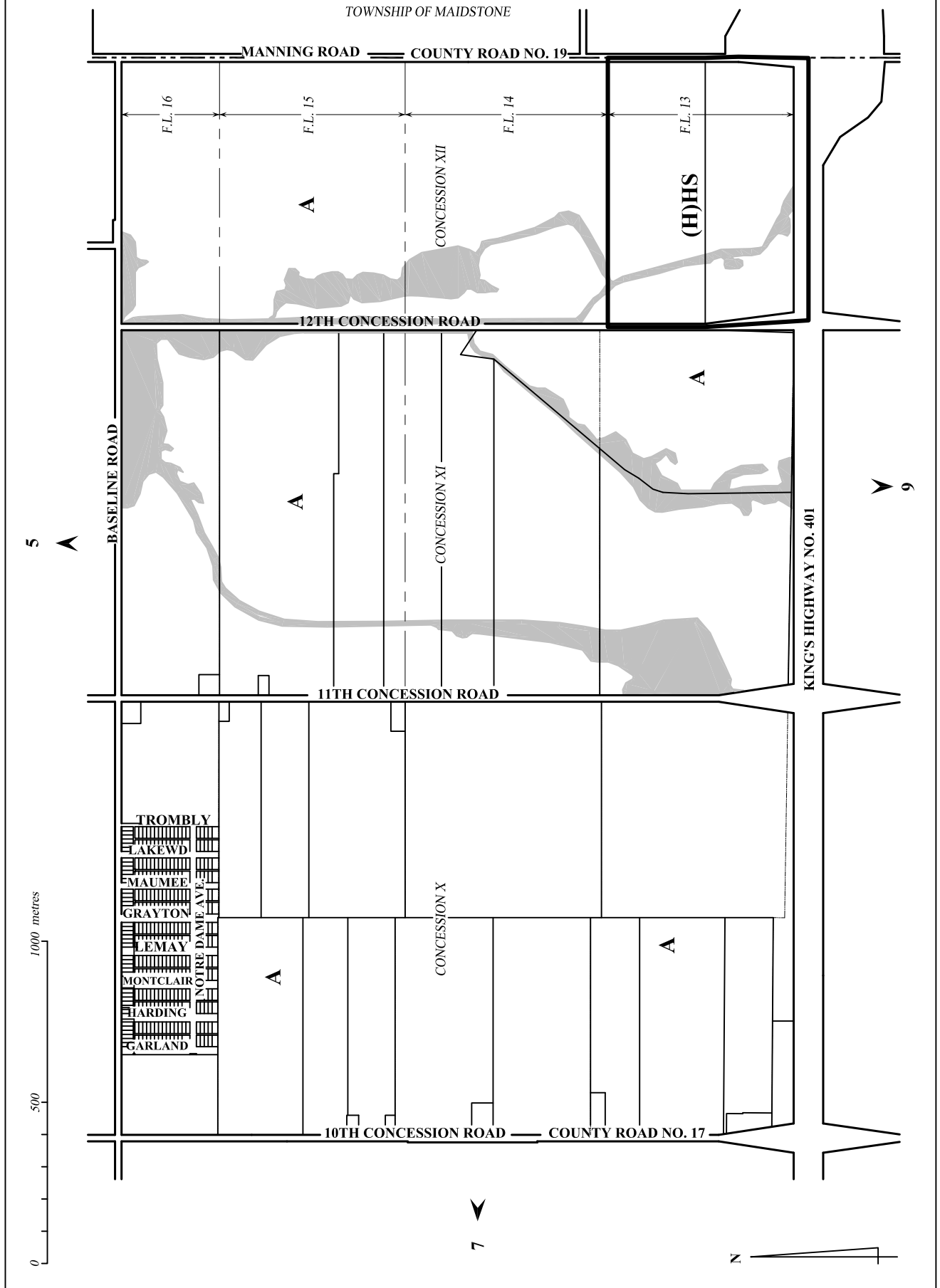

TOWNSHIP OF MAIDSTONE

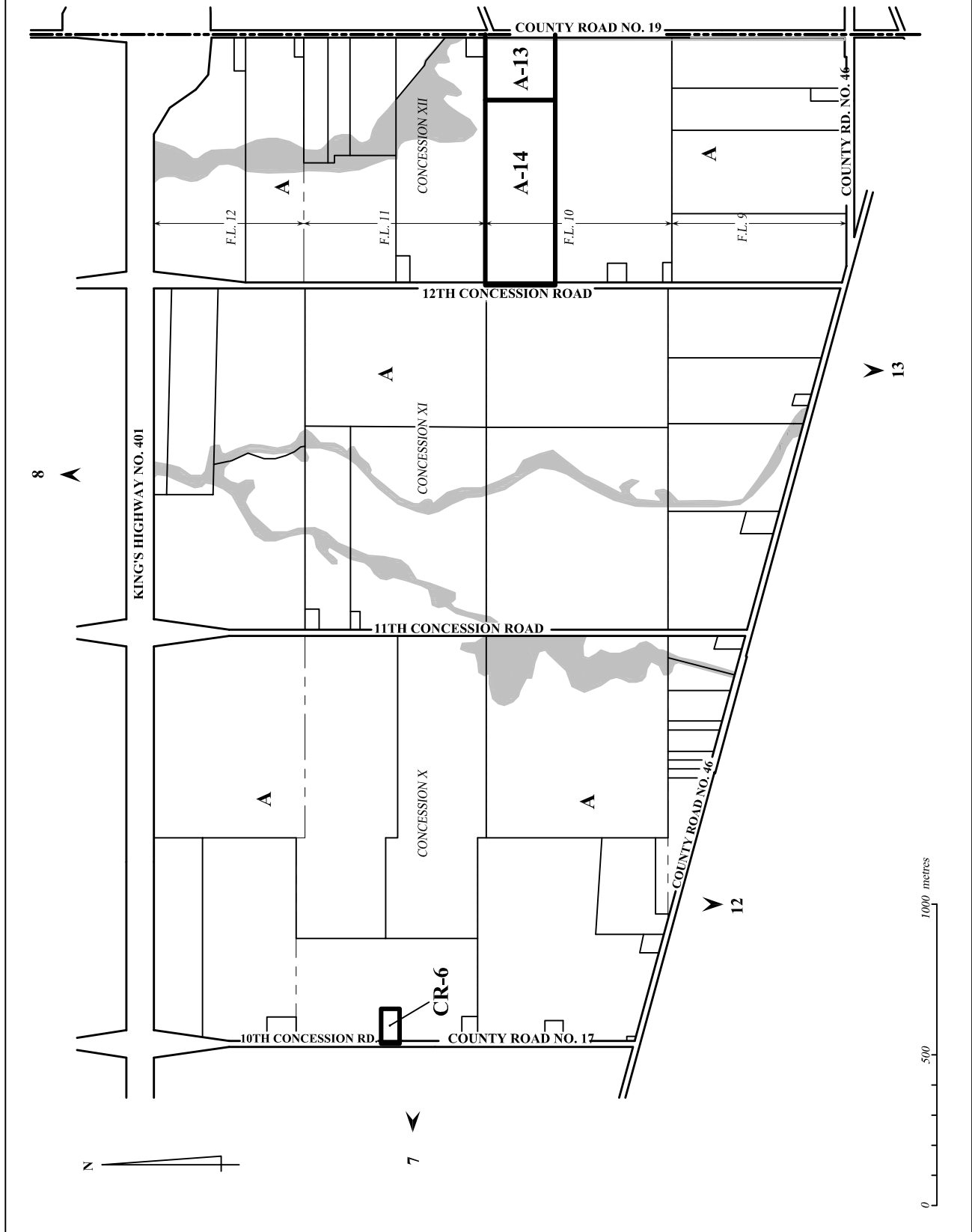

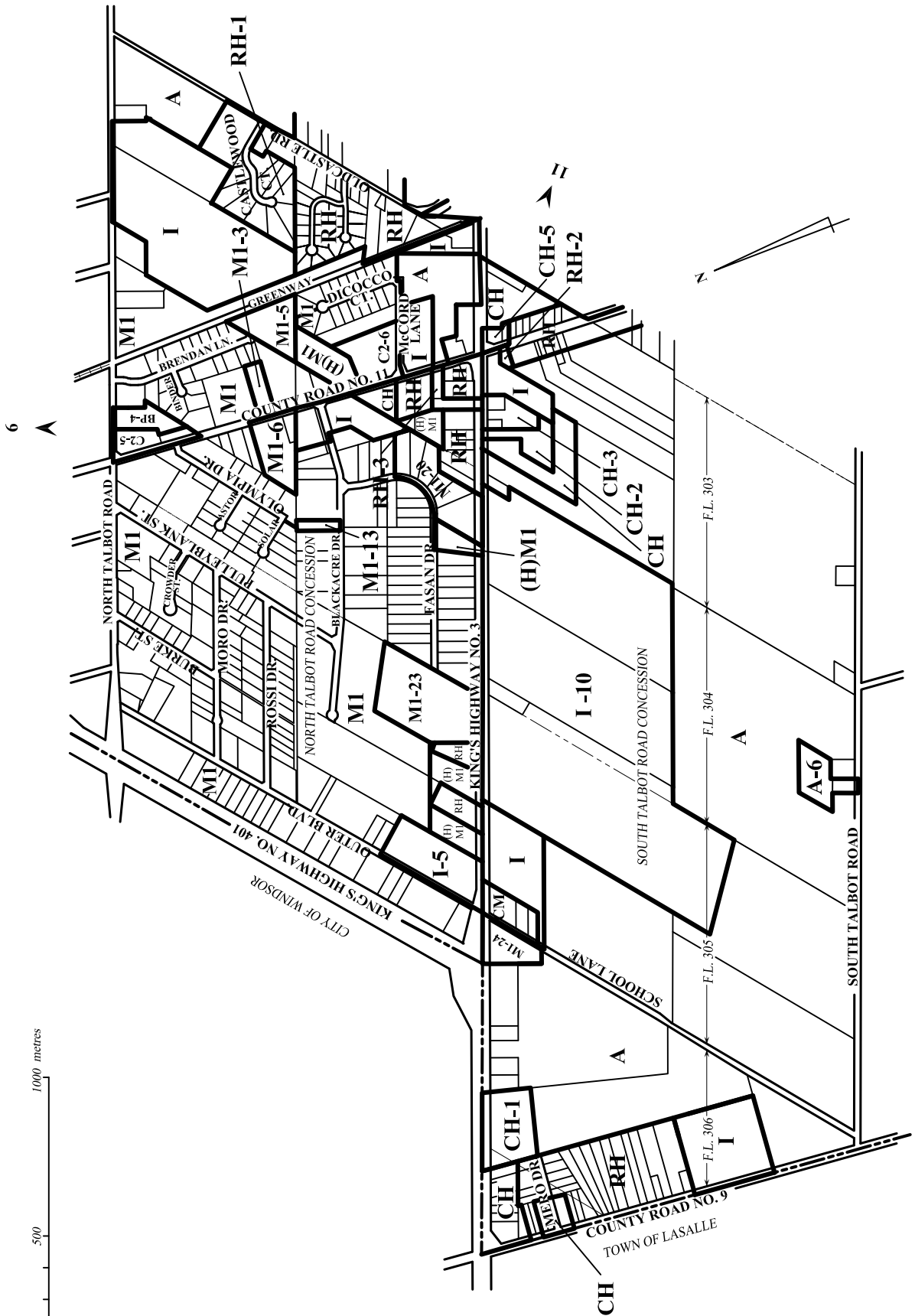

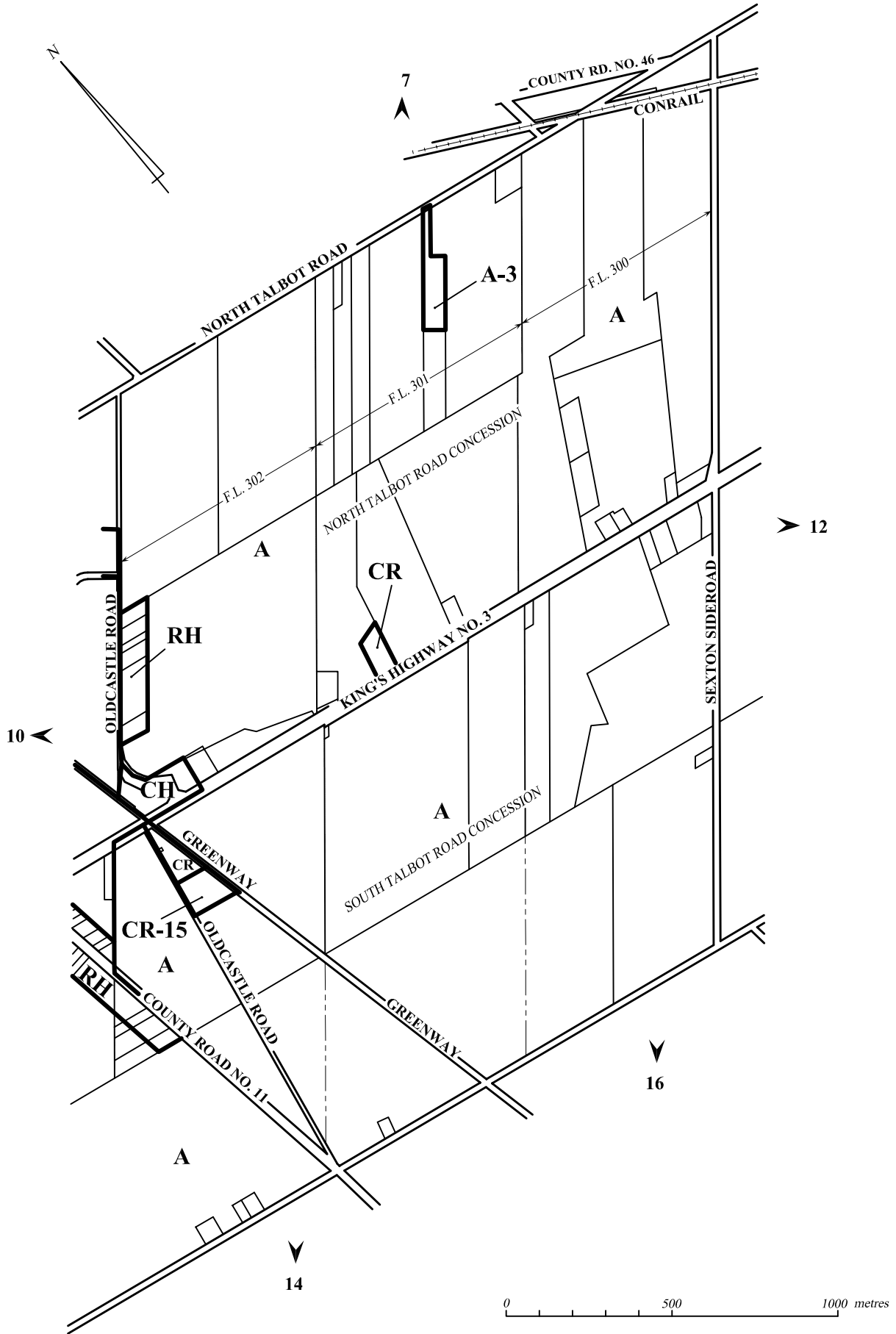

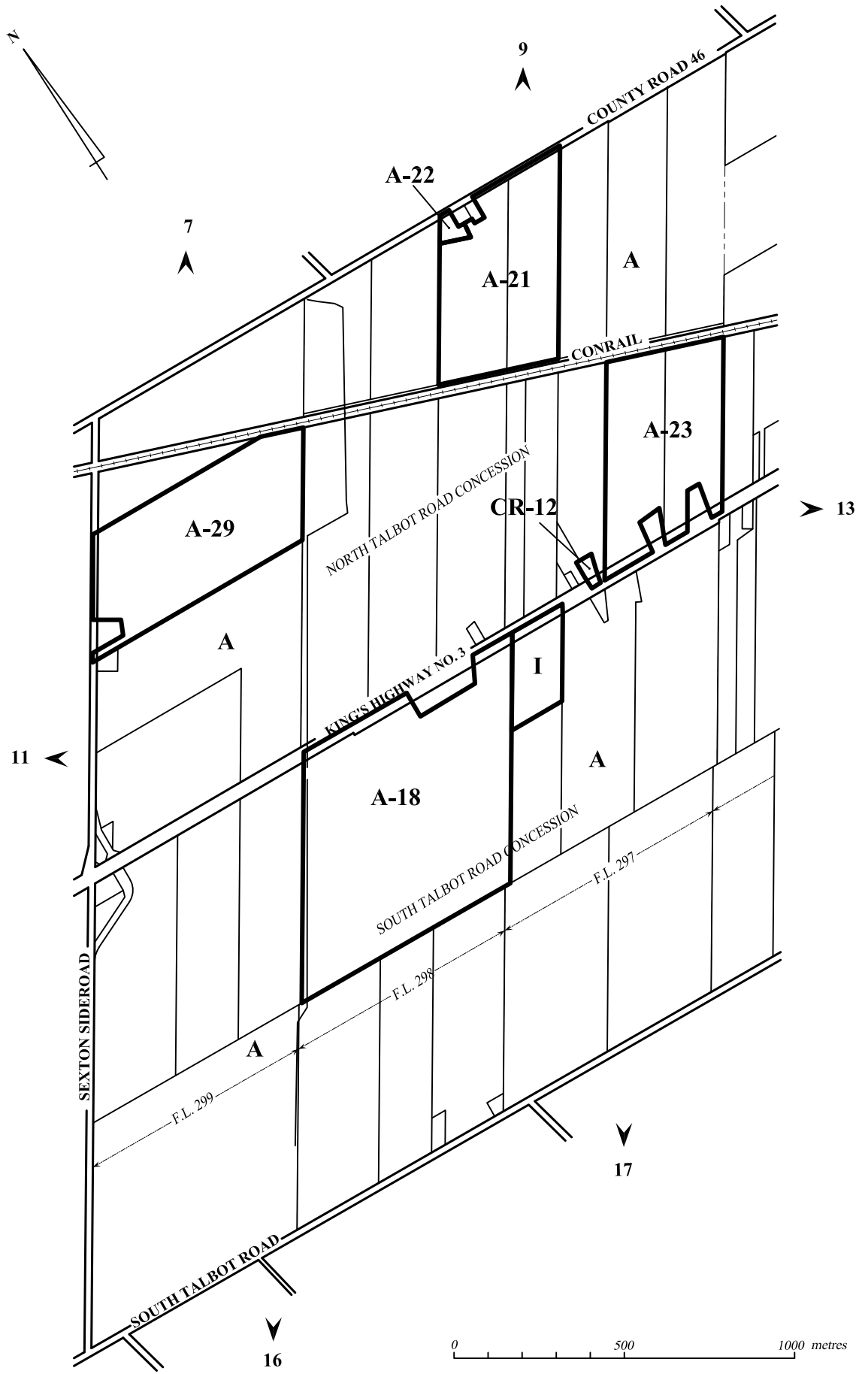

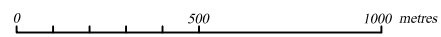
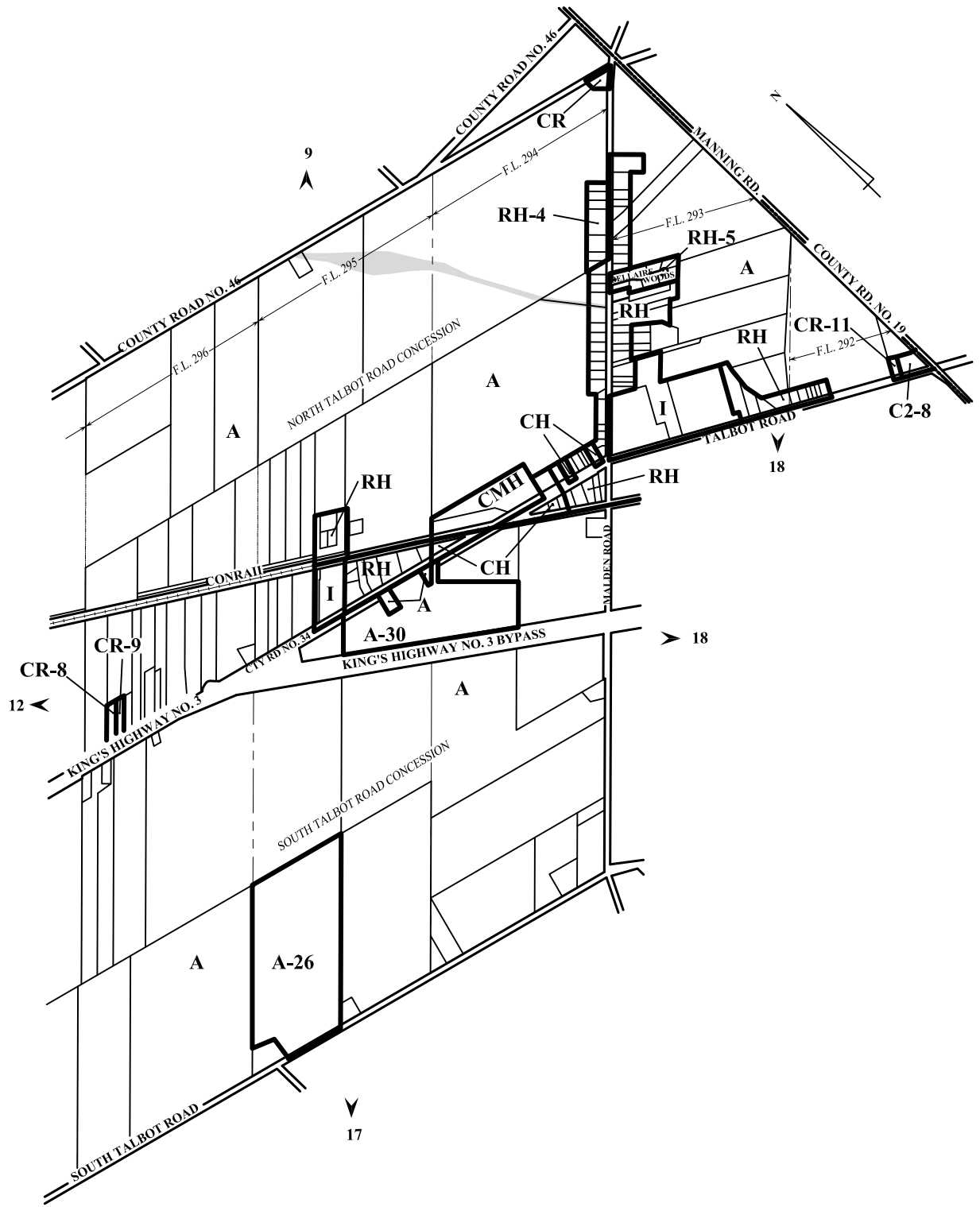

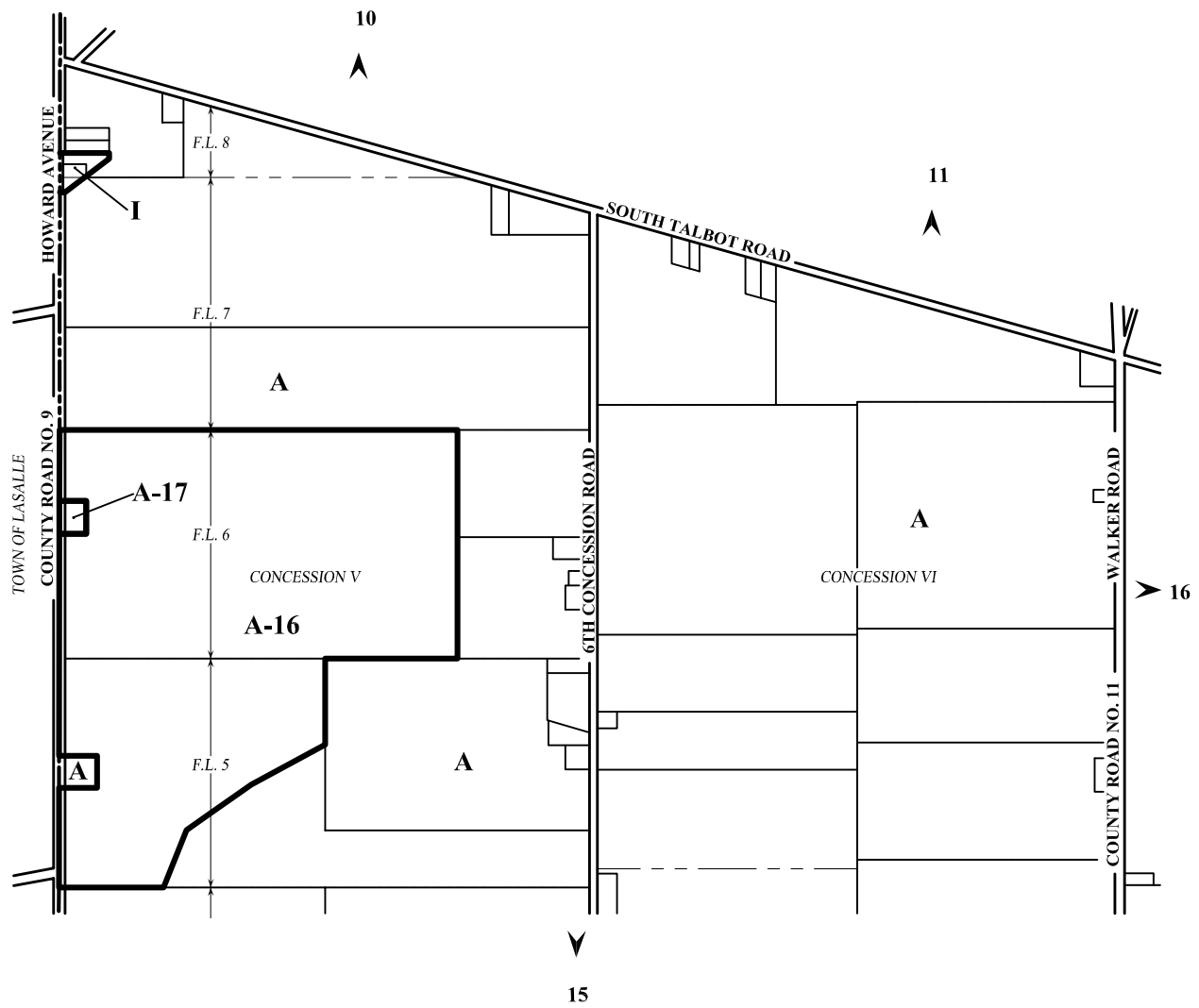

0 500 1000 metres

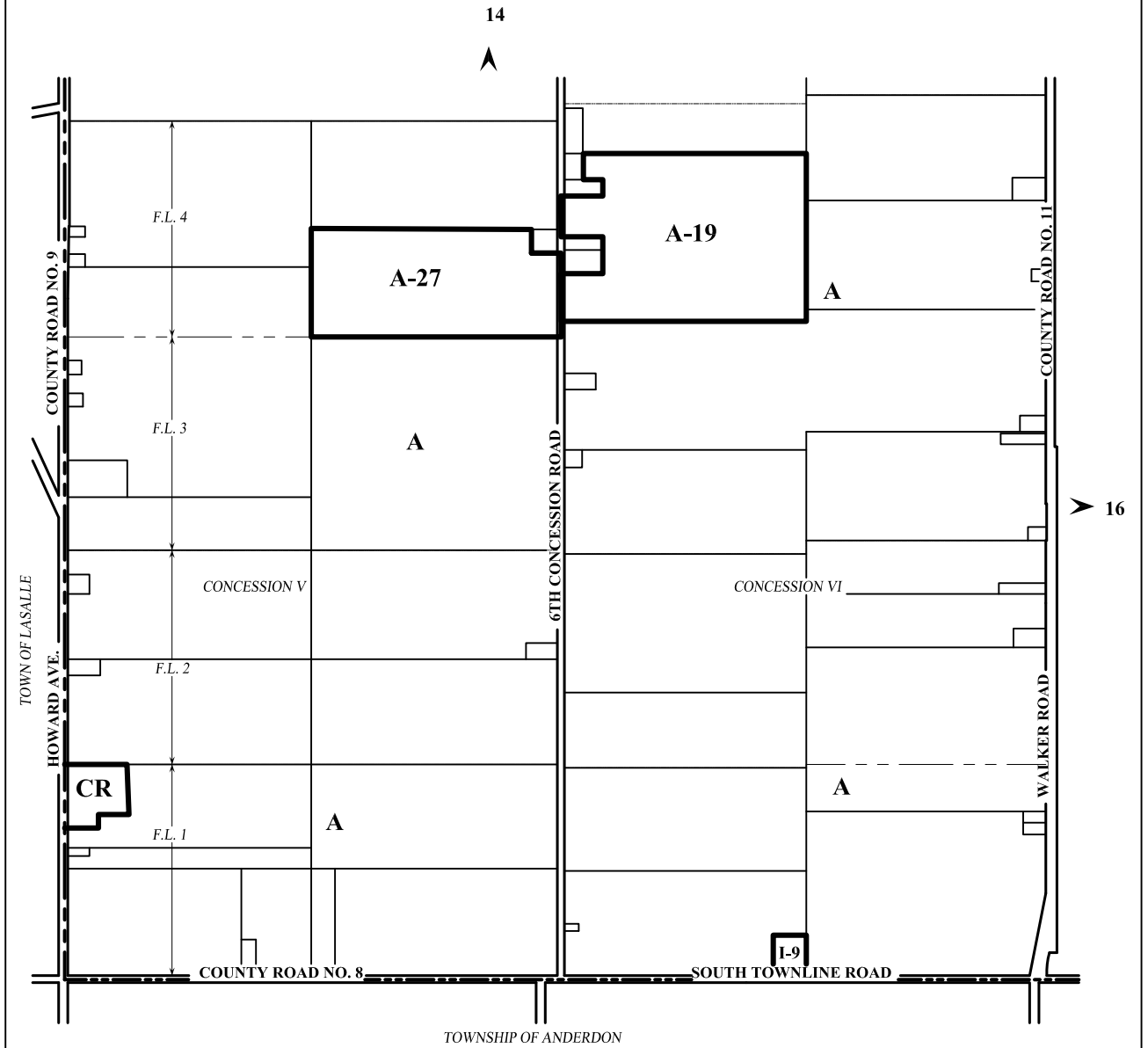

14



16

N

0 500 1000 metres



